

OMRON - SYSWIN

Project Name	V406-51S.SWP
PLC Type	CQM1H
CPU Type	CPU51
Company	MCP Equipment
Plant	Vac-Cast Machine
Project	PLC001 & PLC004
Version	2.051
Promotion	CQM1H version
Date	23/05/02 11:26:41 AM

Contents

Ladder  
PLC Setup

Main 1 - Screen

SOFTWARE V406-51S = MCP 4/06 SLAVE (CQM1H-CPU51)

\*\*\*\*\*CLICK HERE ADDITIONAL FOR SET UP INFORMATION\*\*\*\*\*

The PLC4/06 uses PLC-PLC communications between the "TWO" system PLCs. This is done by linking the "TWO" RS232C ports on the additional "Serial Communications Board" (CQM1H-SCB41) with the below cable.

```

2 ----- 3
3 ----- 2
9 ----- 9
4 & 5      4 & 5  Linked on each end.
    
```

DM6555 needs setting as indicated in the address comments

Master System DM6555 = 3000  
 Slave System DM6555 = 2000

The NT30 connection is unchanged.

Network 1 - Update control

Update the NT control area

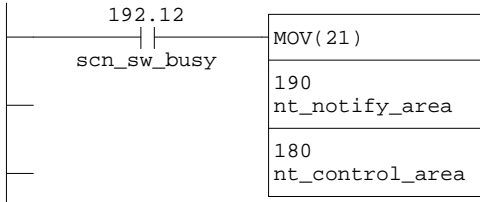

Network 2 - Page 1 default

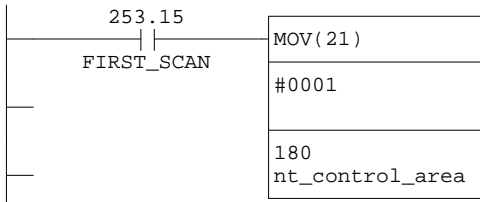

Network 3 - Auto "ESC" key

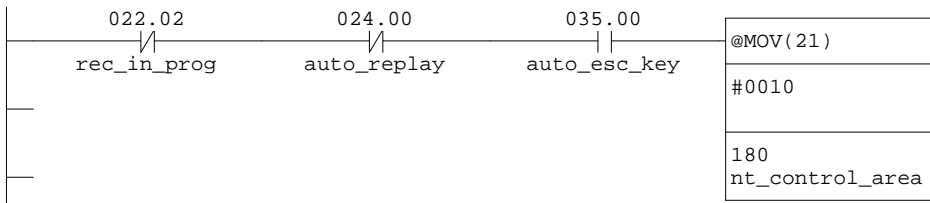

Network 4 - Auto ESC lamp

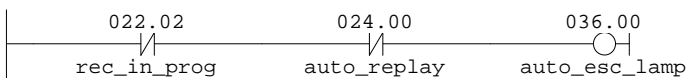

Network 5 - Auto Rec PB

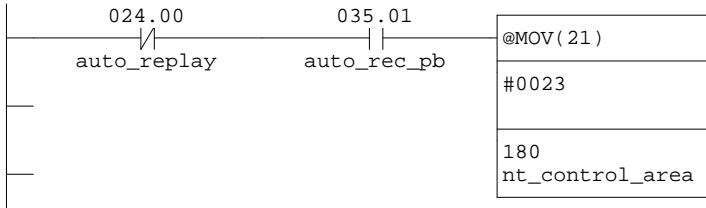

Network 6 - Auto Rec lamp

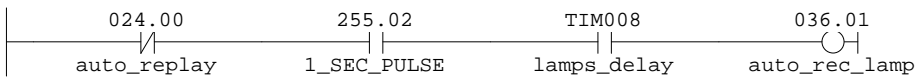

Network 7 - Auto Monitor PB

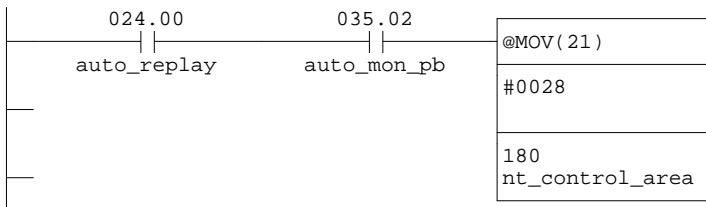

Network 8 - Auto Mon lamp

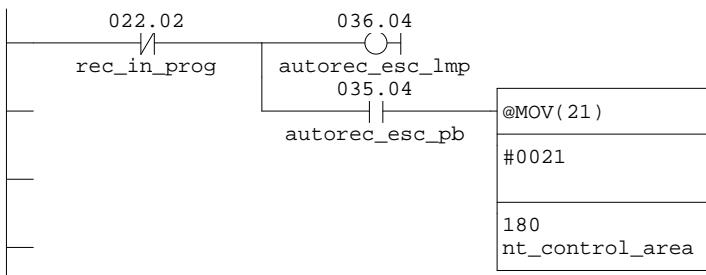
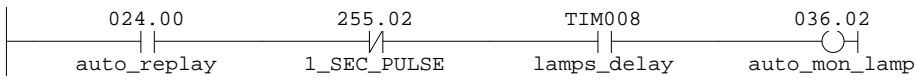

Network 10 - Man ESC key

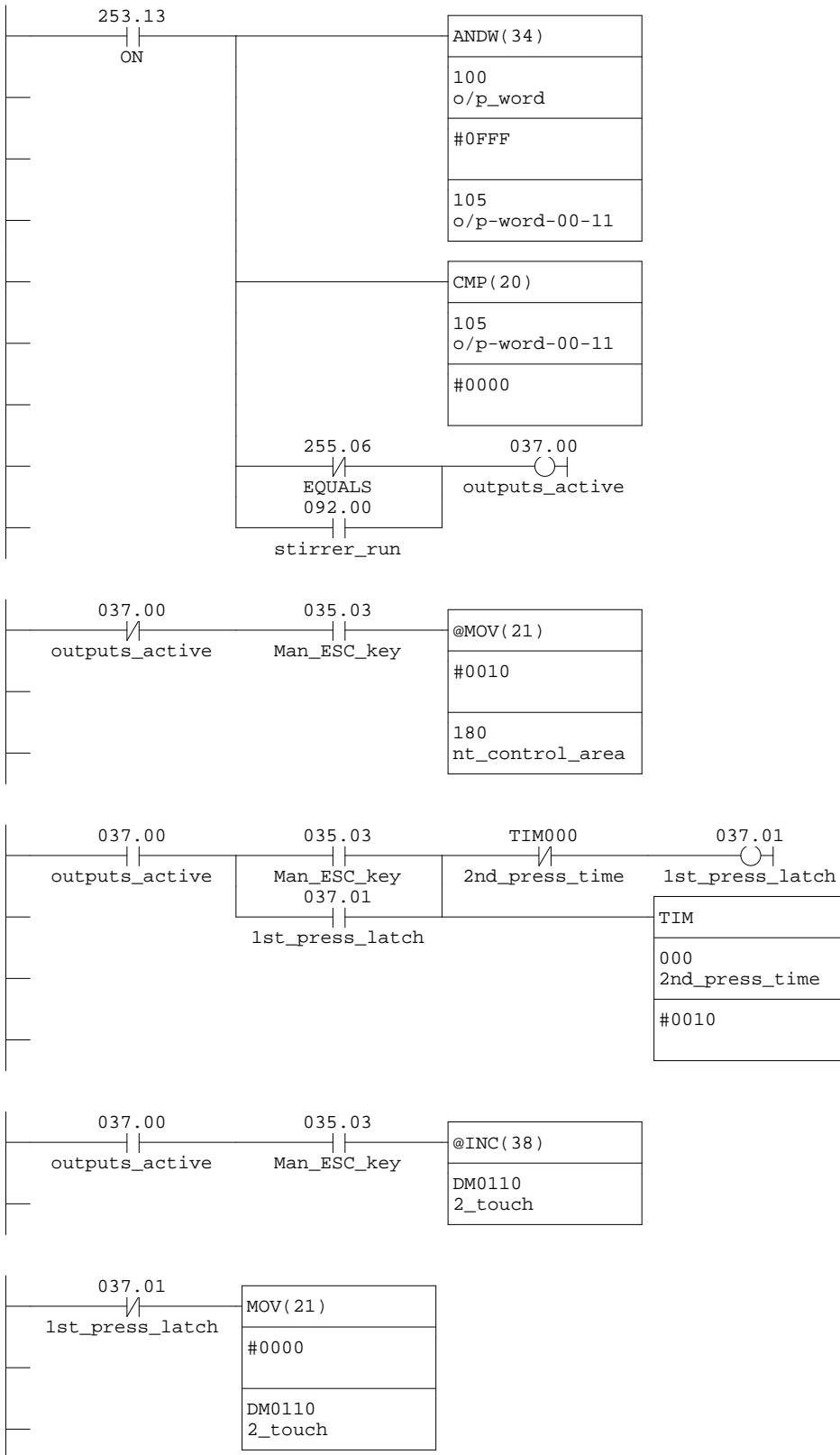

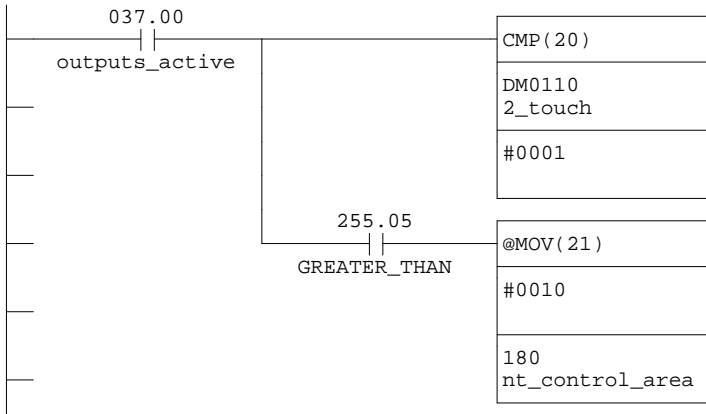

Network 16 - Man ESC lamp

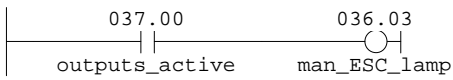

Network 17 - Al/Hist ESC key

Alarm and History escape keys

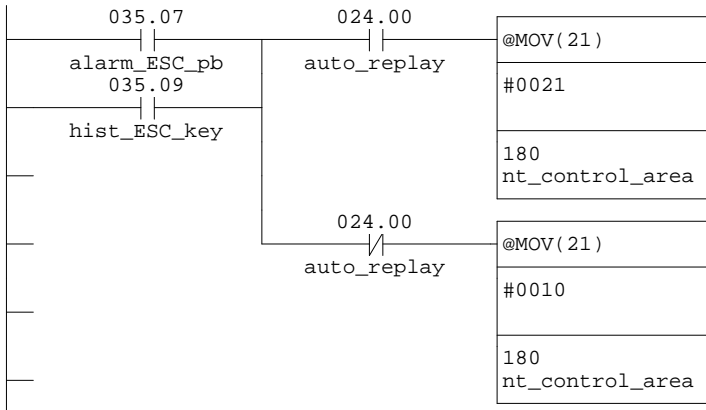

Network 18 - Al/Hist ESC lmp

Alarm and history page escape button lamps

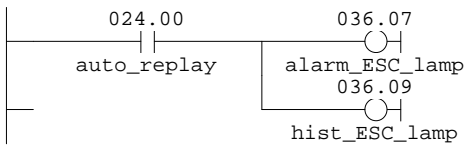

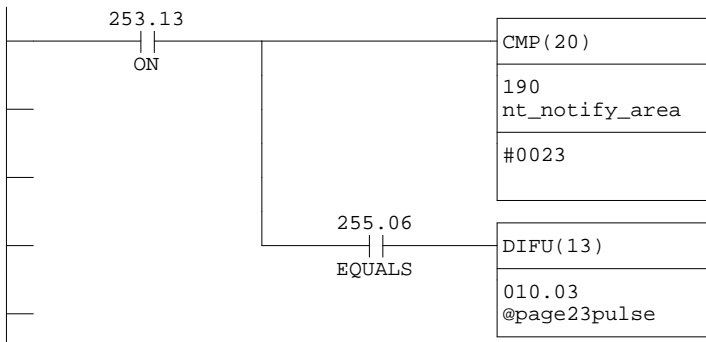
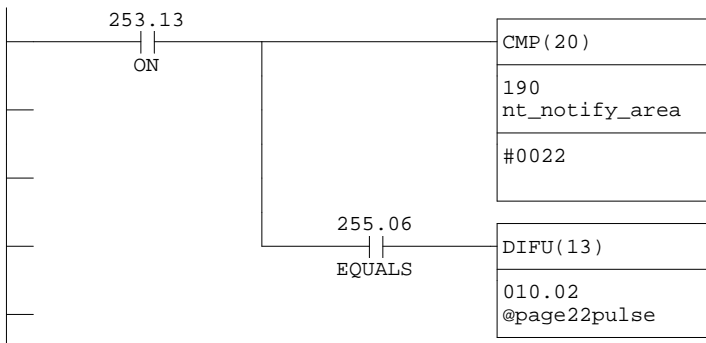
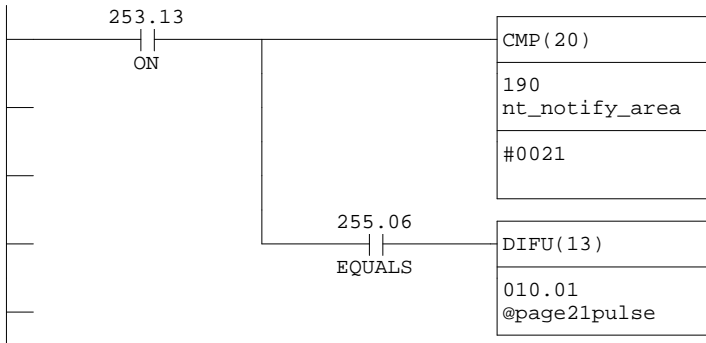
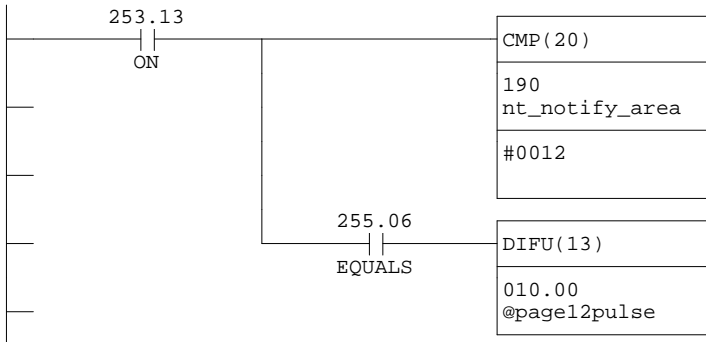

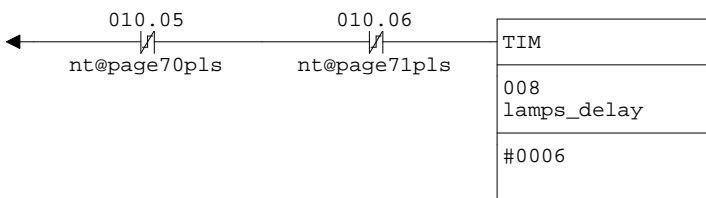
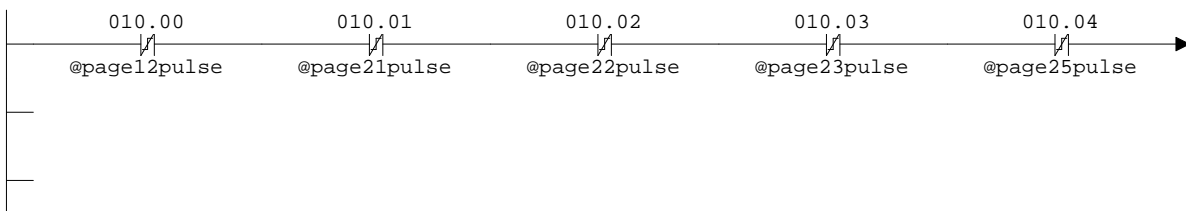
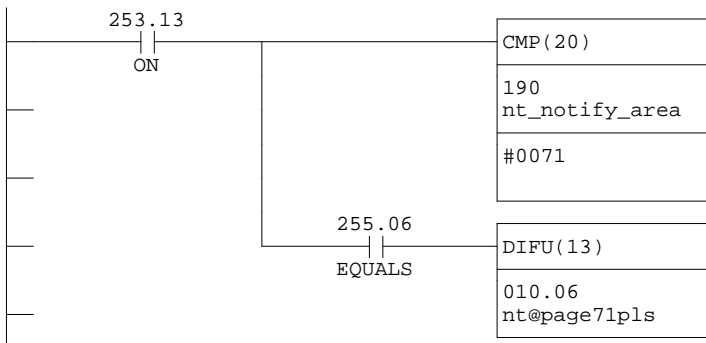
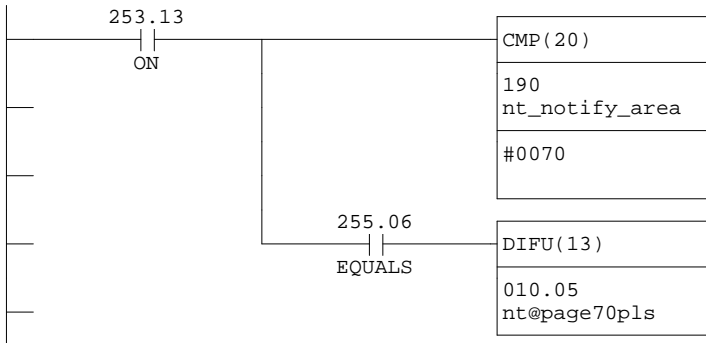
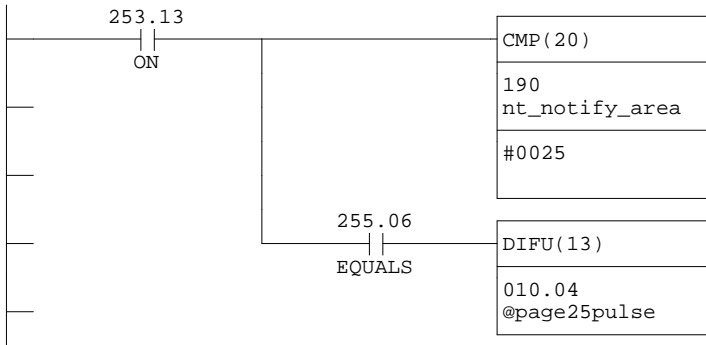

Network 27 - PLC revision No

Ladder software revision number

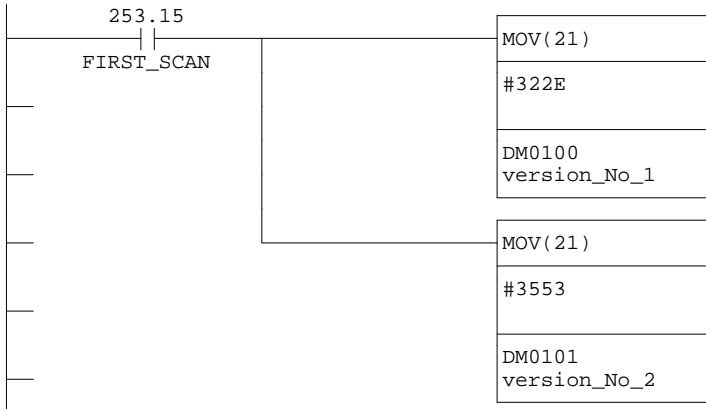

Network 28 - Def Leak Time

Default leak time set on first scan if no value set.

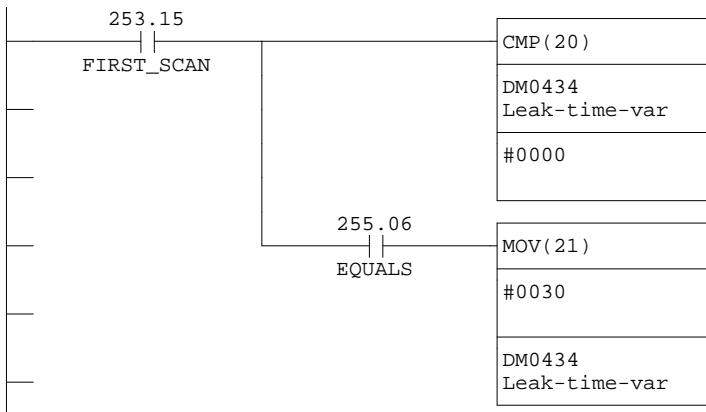

Main 2 - Alarms

Network 1 - E/stop

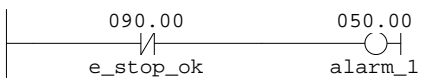



Network 2 - Analogue input

Check analogue input setting is OK

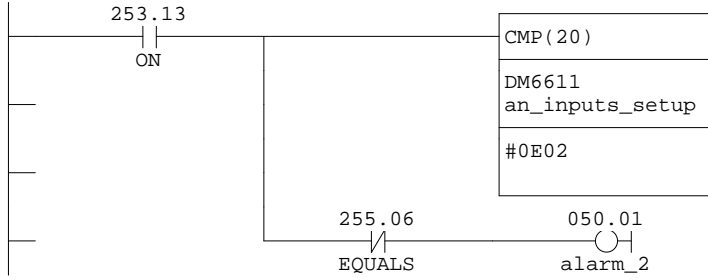

Network 3 - Start up mode

Check start up mode setting is OK

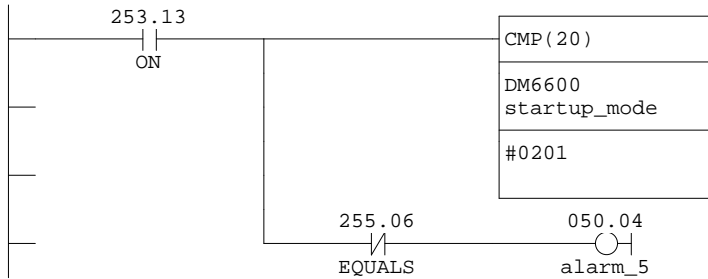

Network 4 - Backlight



Network 5 - Int Buzzer

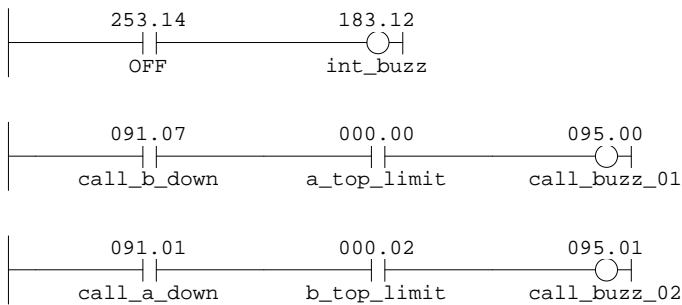

Network 8 - Cont Buzzer

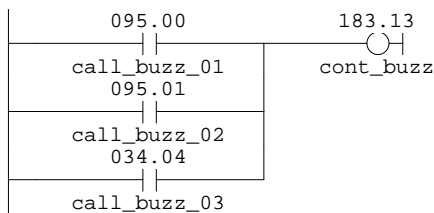

Network 9 - Screen display

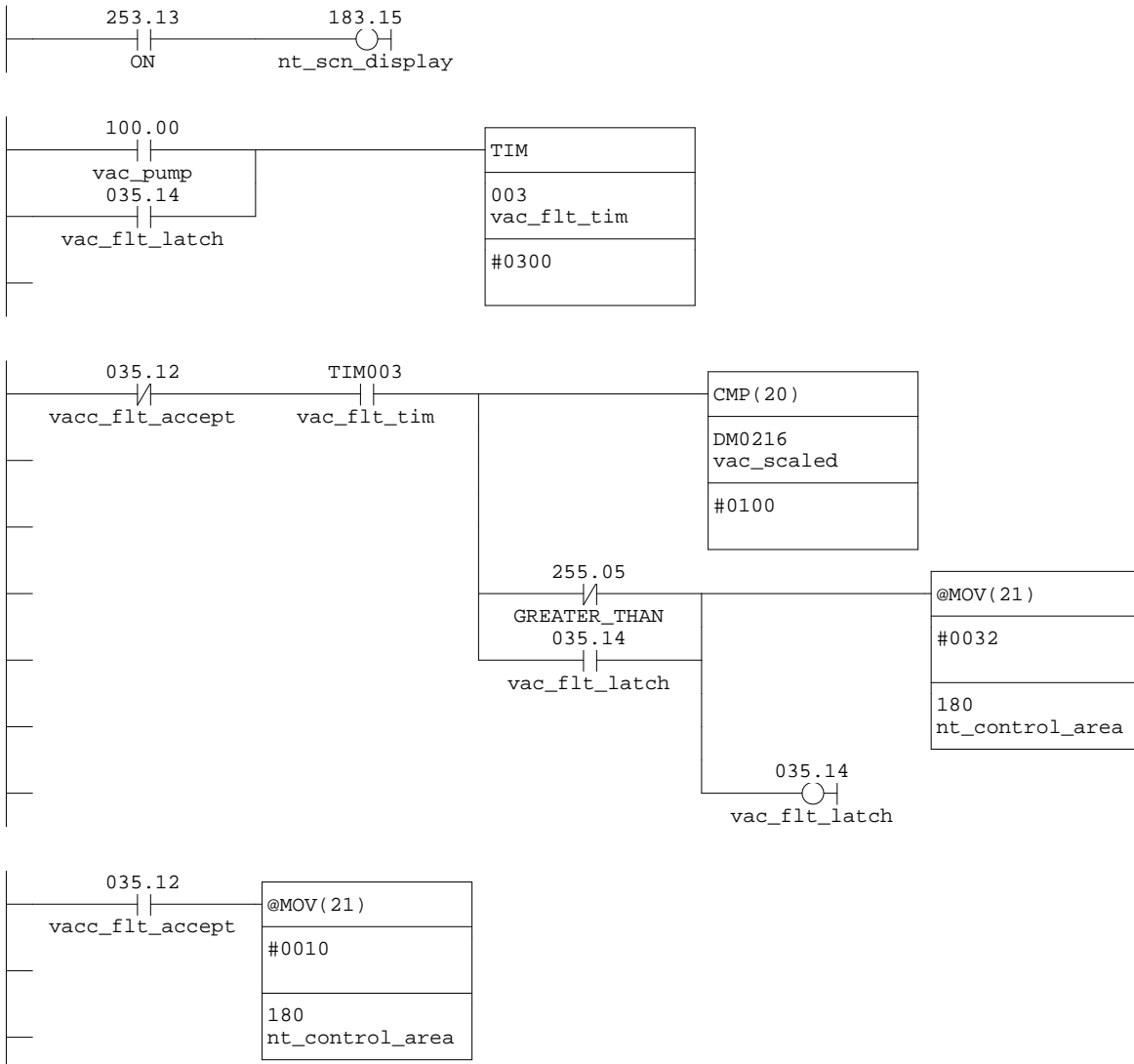

Network 13 - Wax-Sensor-Err

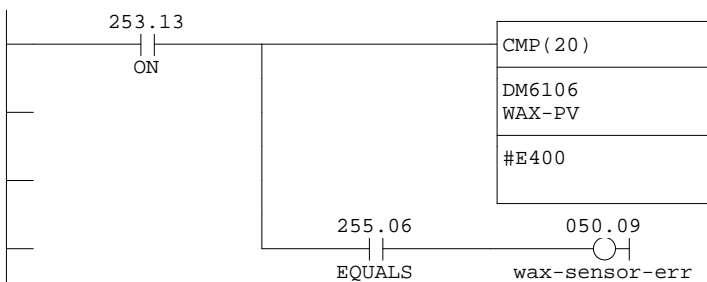

Network 14 - Wax-alm-Hold1

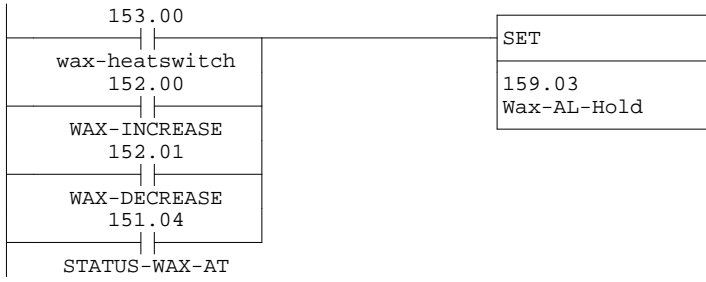

Network 15 - Wax-alm-Hold2



Network 16 - O/T alarm wax

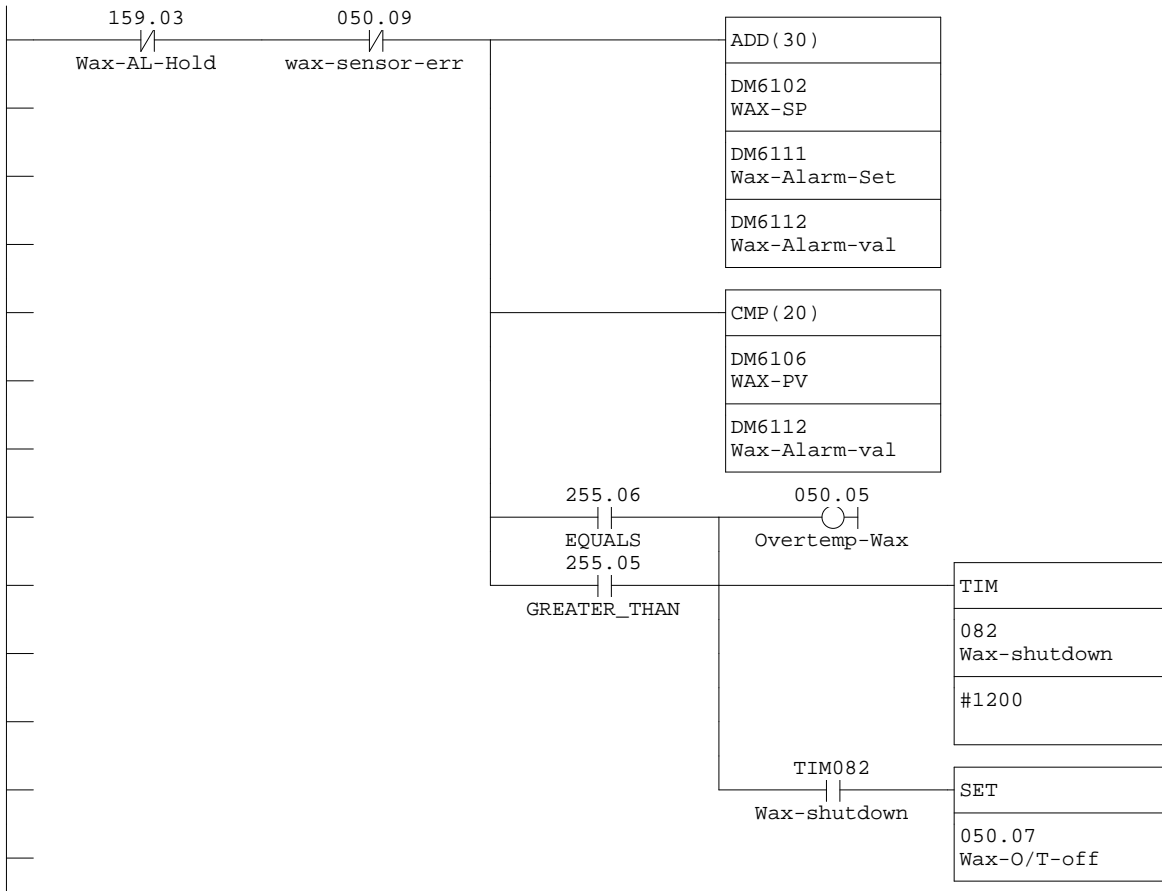

Network 17 - Wax-s/down-res

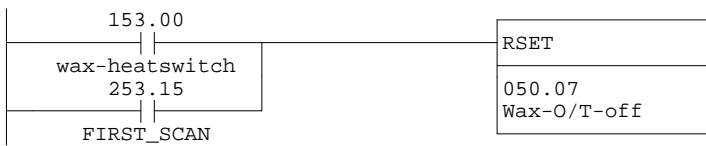

Network 18 - Oven-Sensor-err

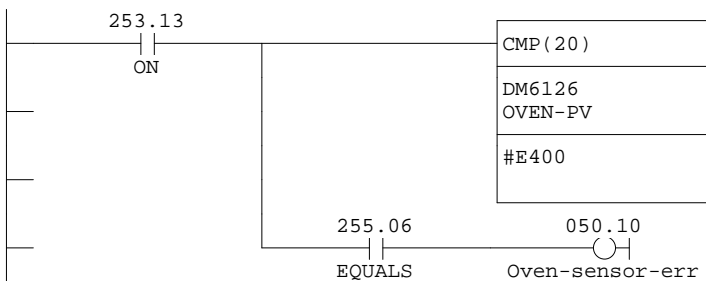

Network 19 - Oven-alm-Hold1

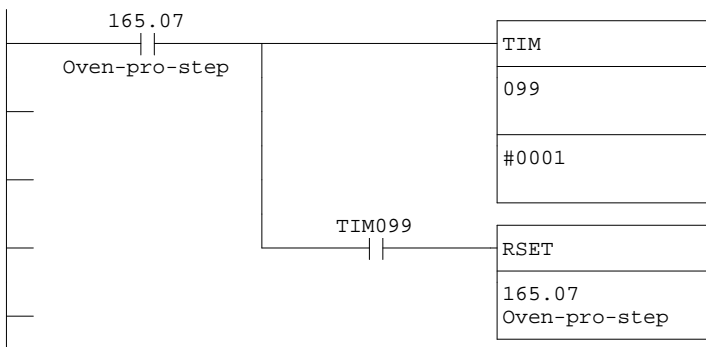
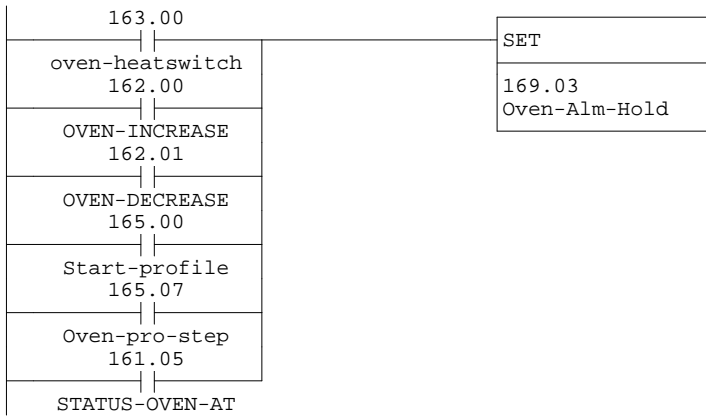

Network 21 - Oven-alm-Hold2



Network 22 - O/T alarm oven

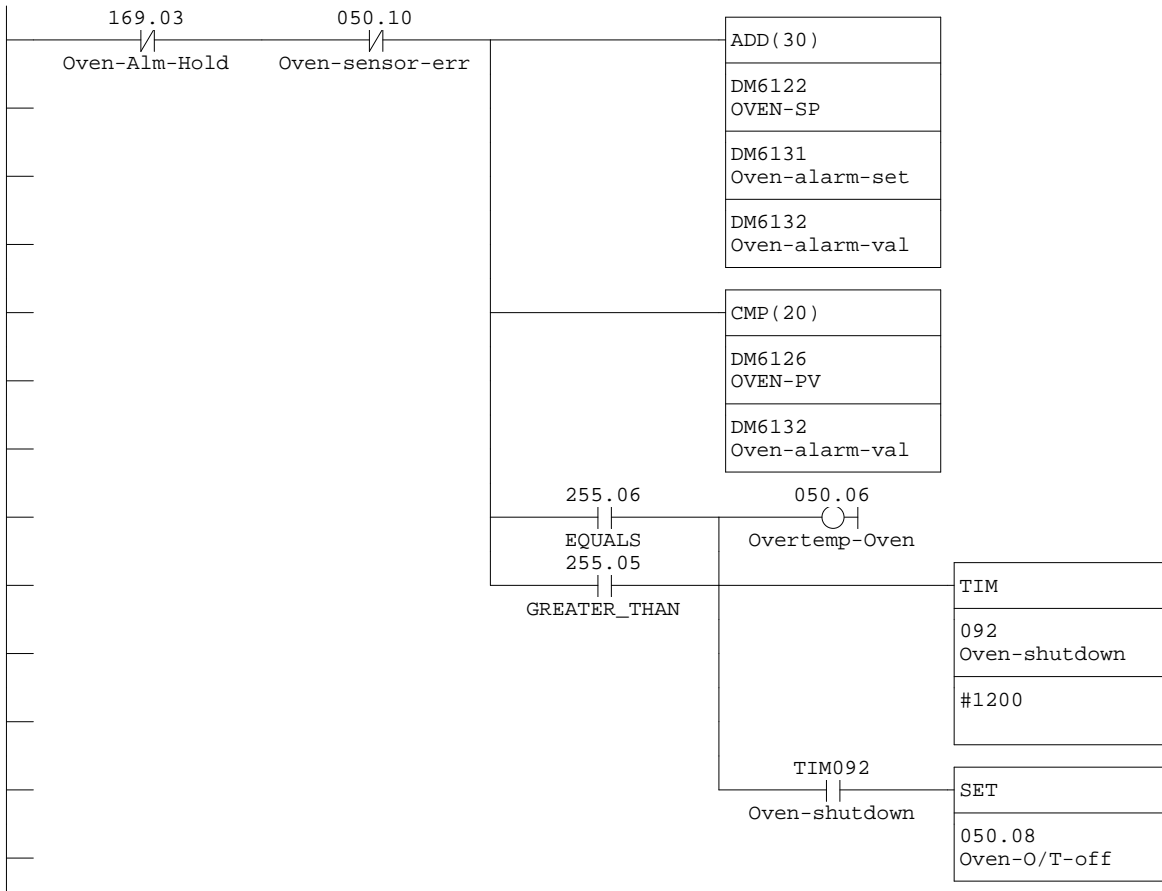

Network 23 - Oven-s/down-res

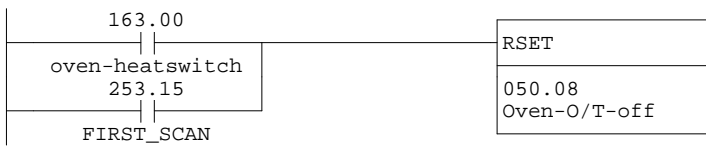

Main 3 - Vacuum display

Network 1 - Set scaling

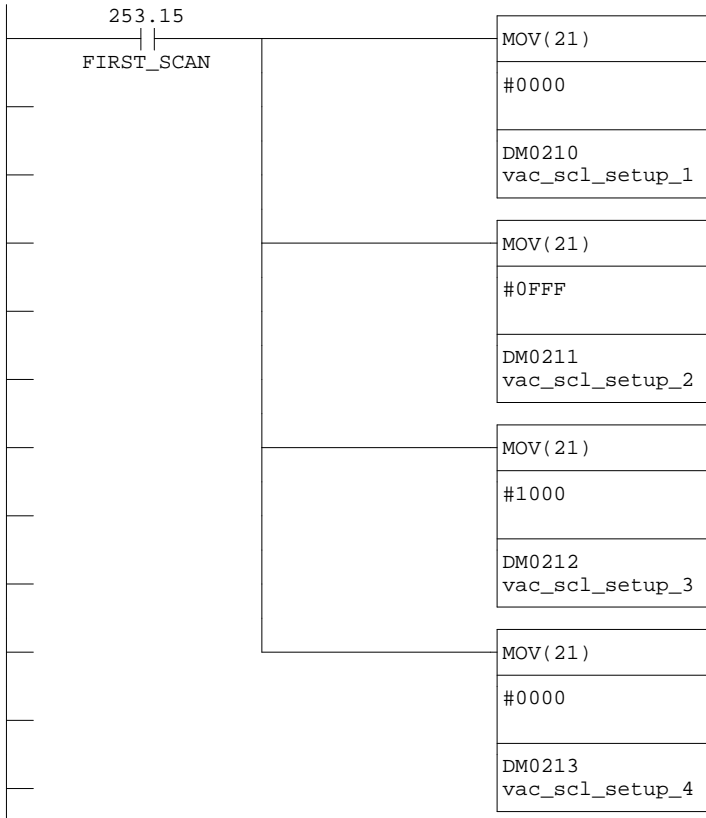

Network 2 - Scale display

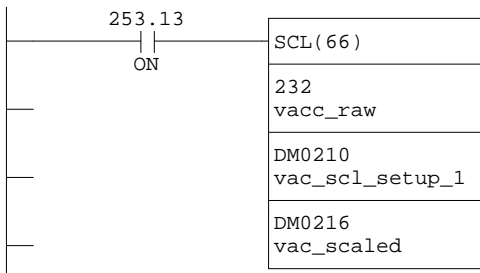



Network 3 - Limit display

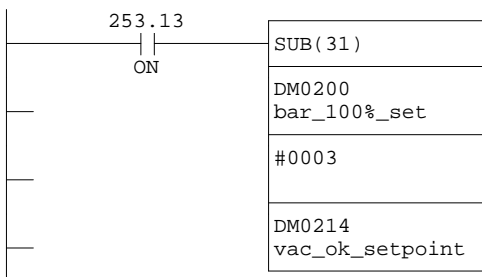
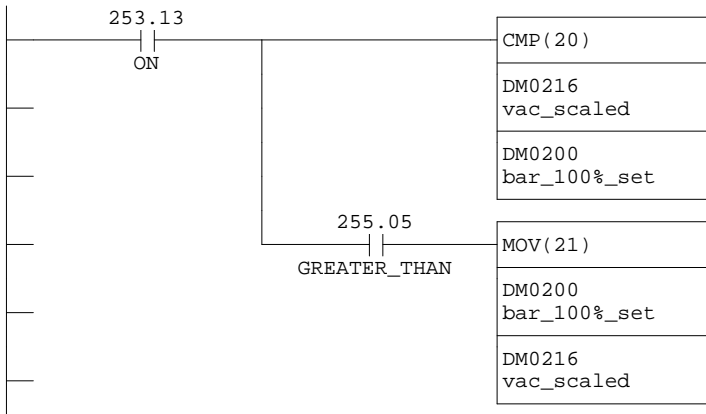

Network 5 - Vacuum OK

Vacuum "OK" light

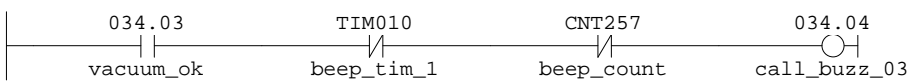
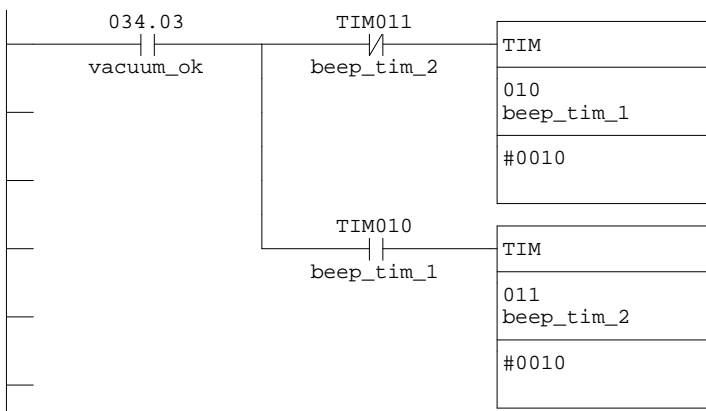
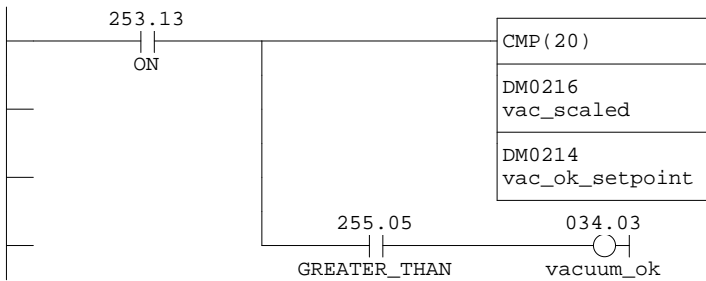

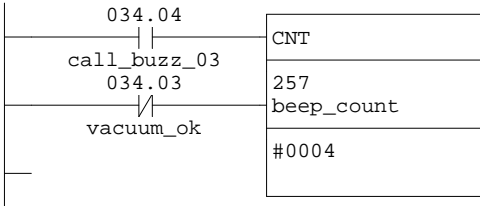

Main 4 - Run time+Hidden

Network 1 - Set DM's

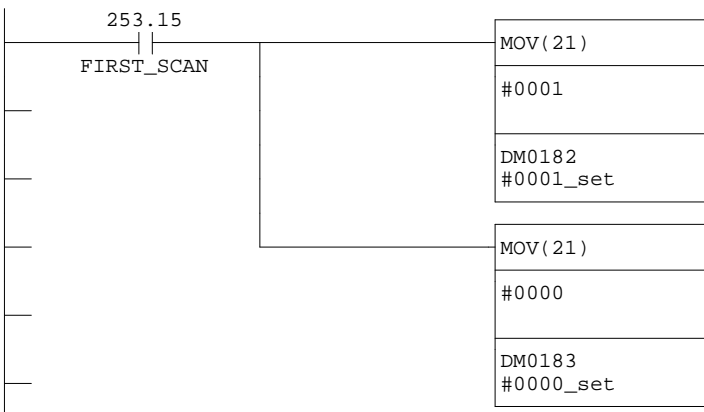

Network 2 - Minute timer

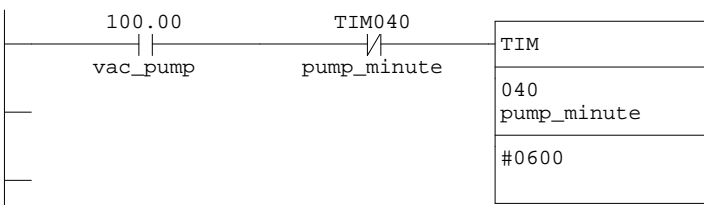

Network 3 - Minute counter

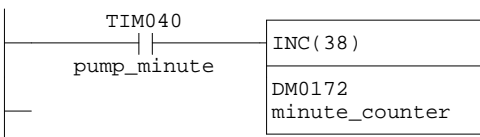

Network 4 - Hours count

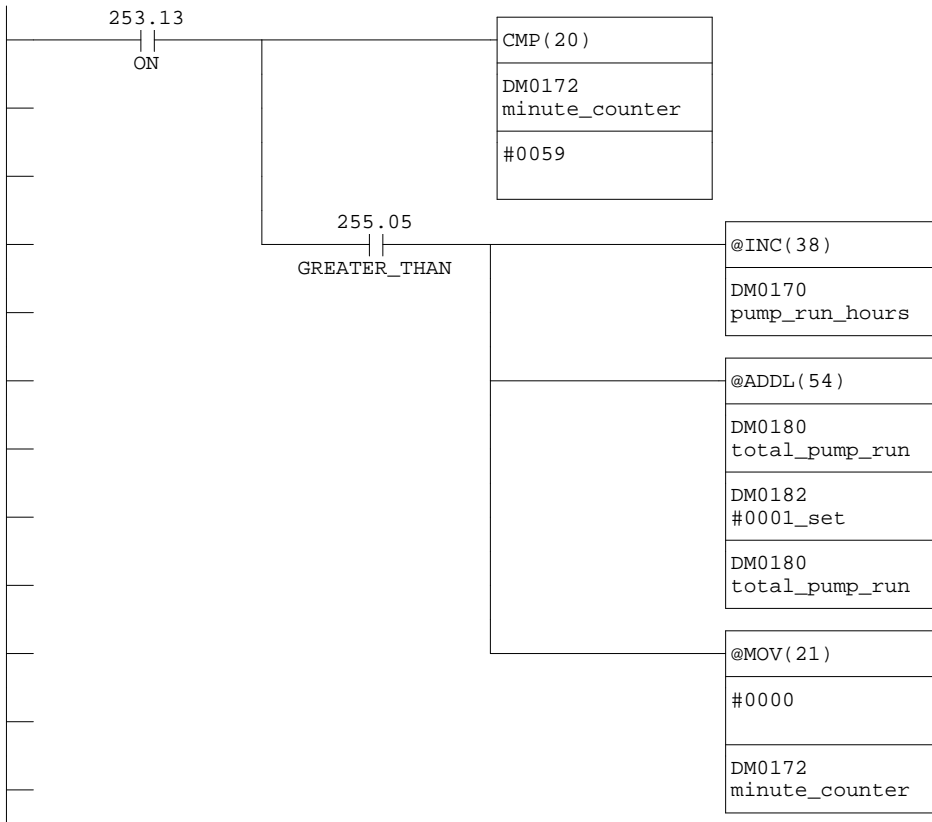

Network 5 - Reset count

Reset count and send alarm to History.

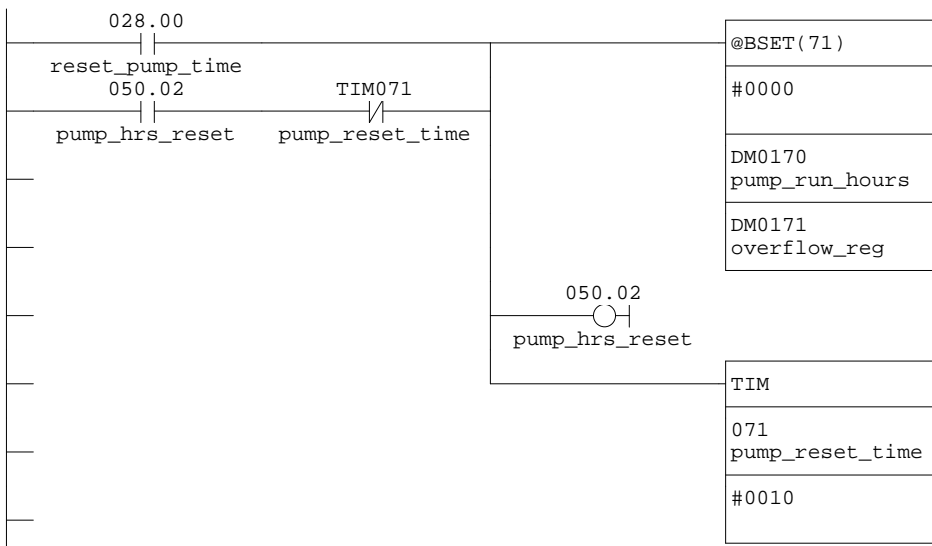

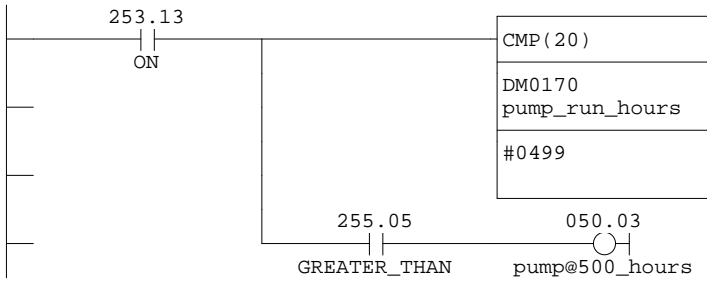

Network 7 - Goto password

Goto password screen

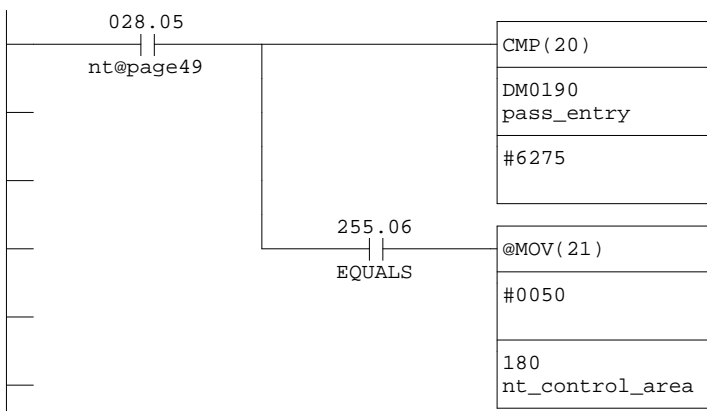
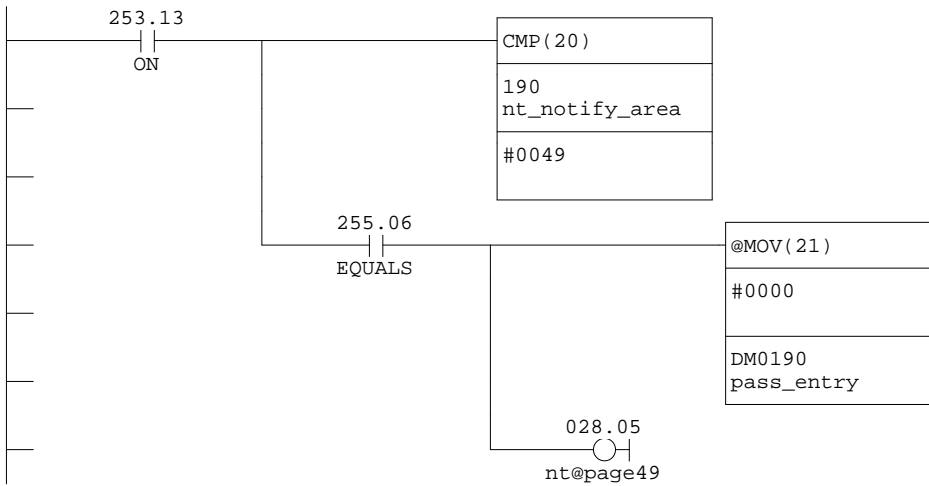
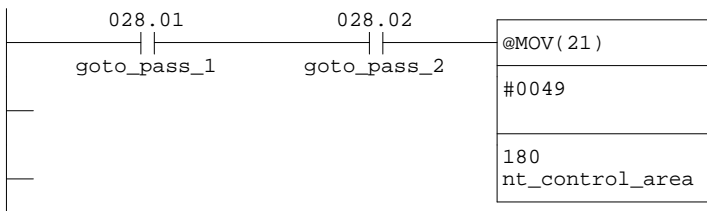

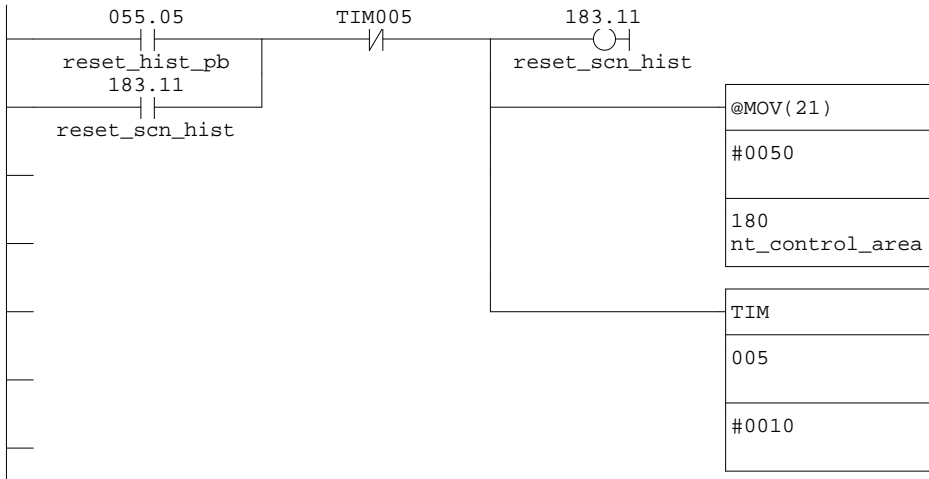

Main 5 - Hoist Control

This block controls the raising and lowering of the hoist.

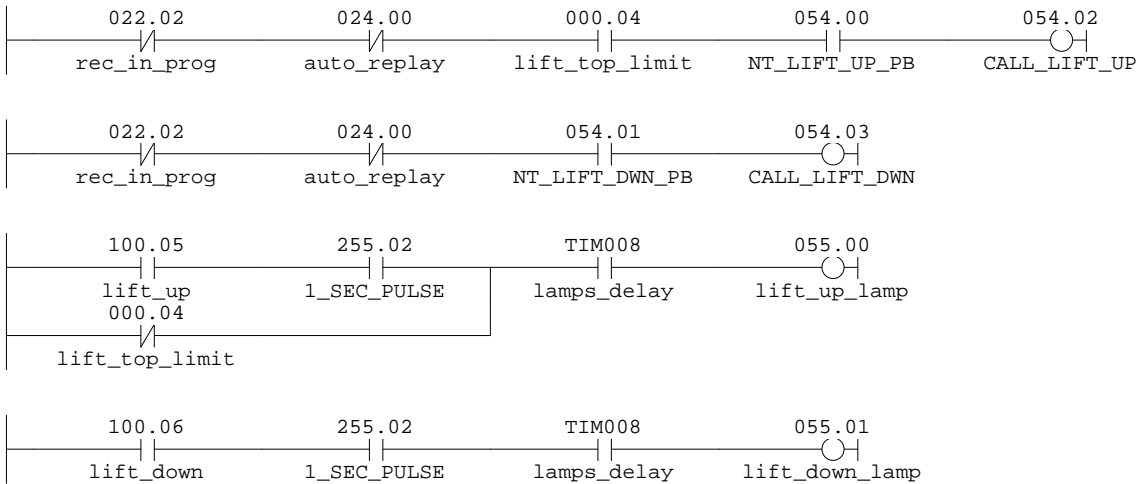

Main 6 - Select Recipe

Network 1 - Set default

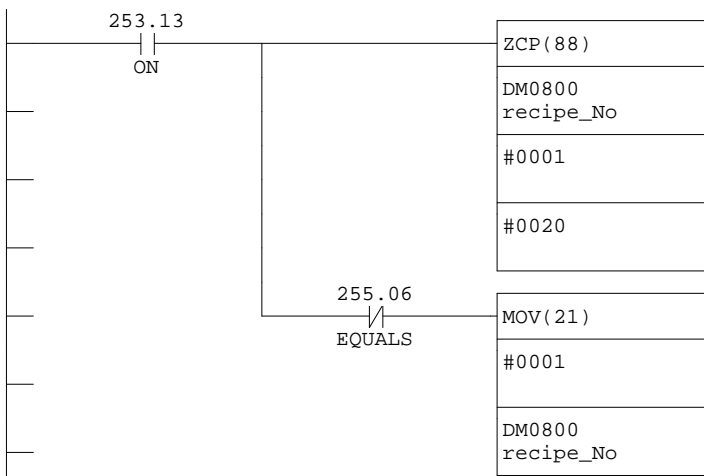

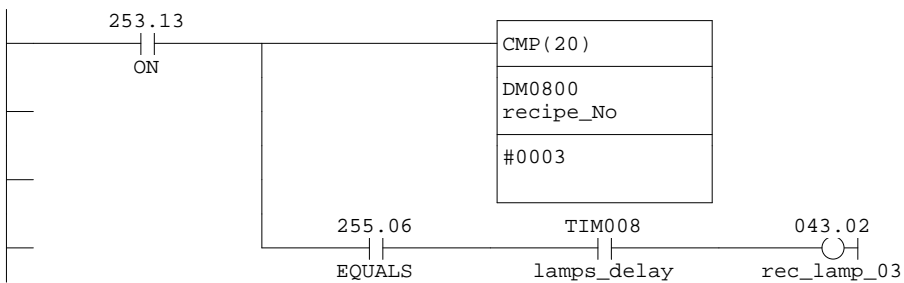
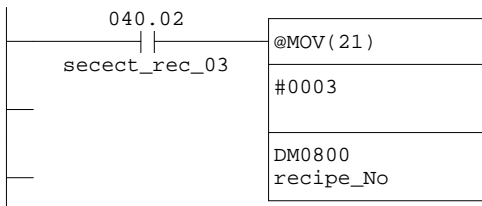
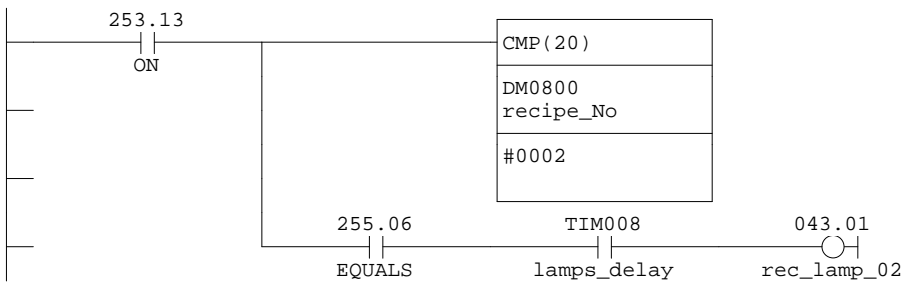
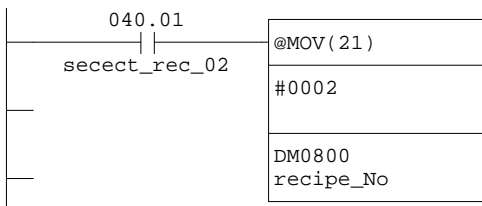
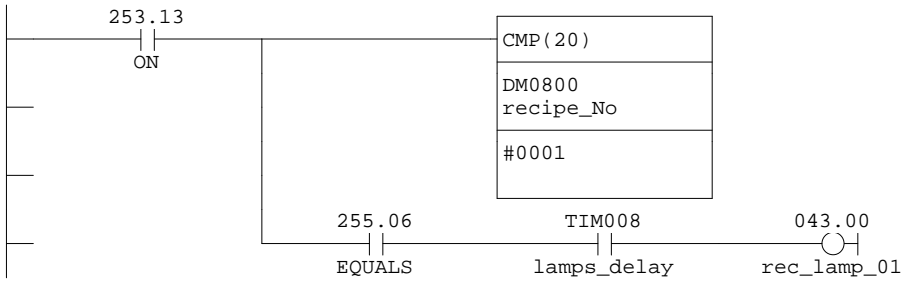
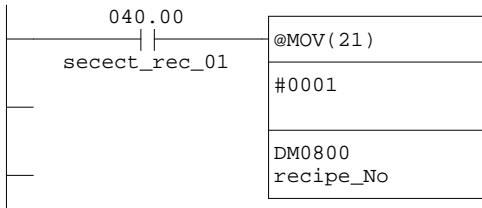

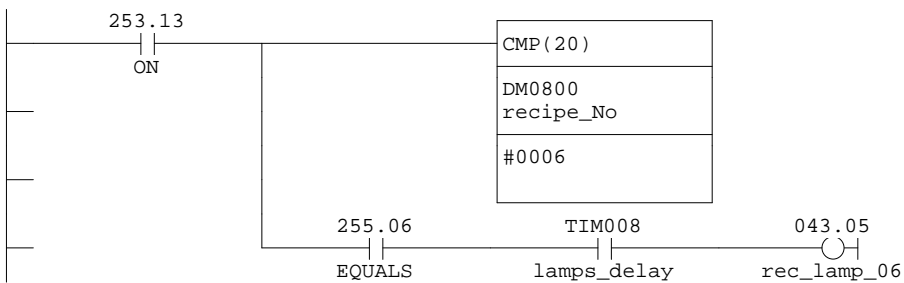
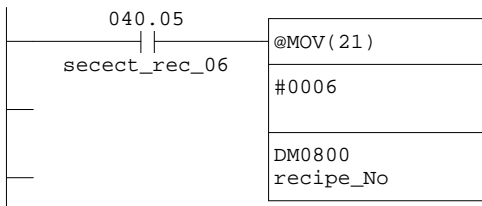
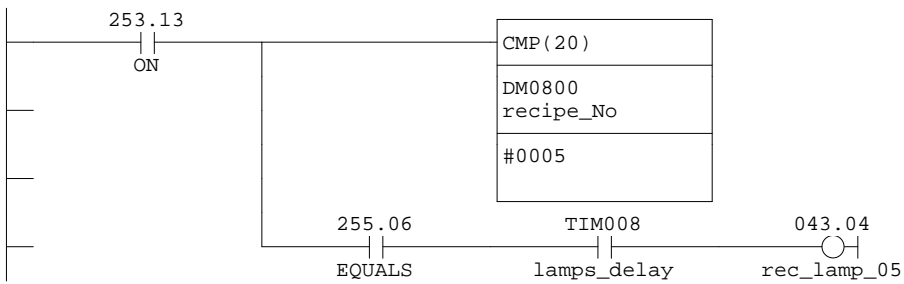
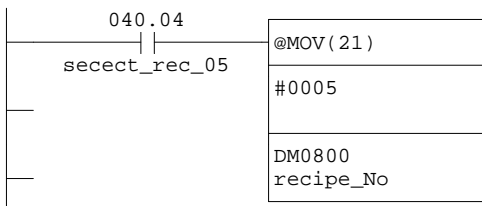
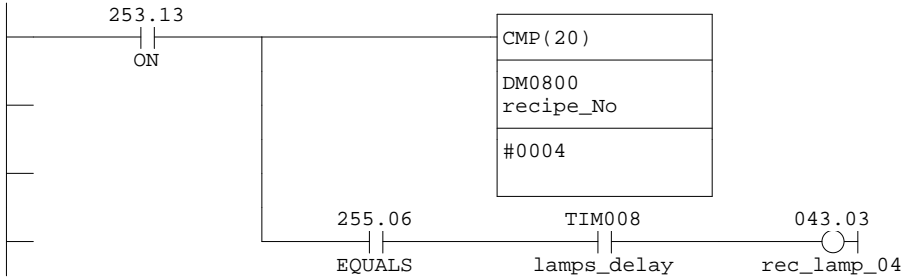
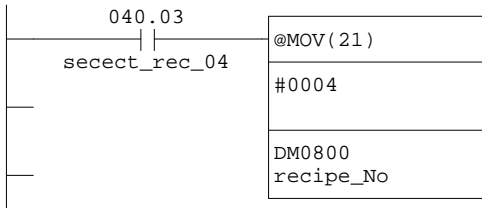

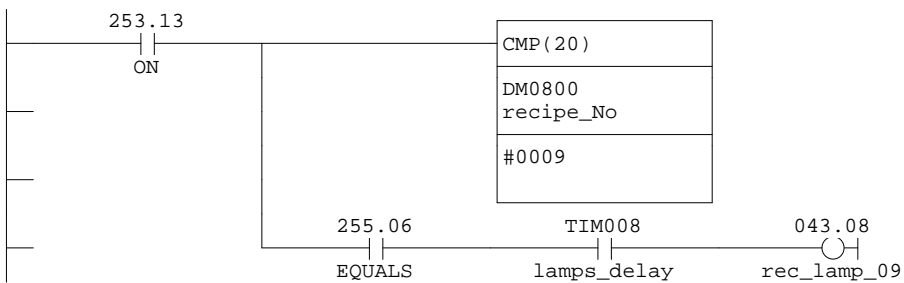
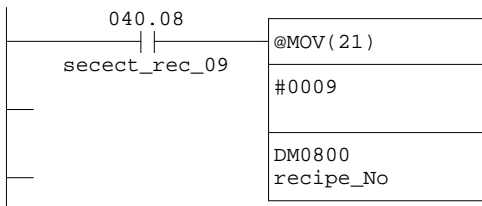
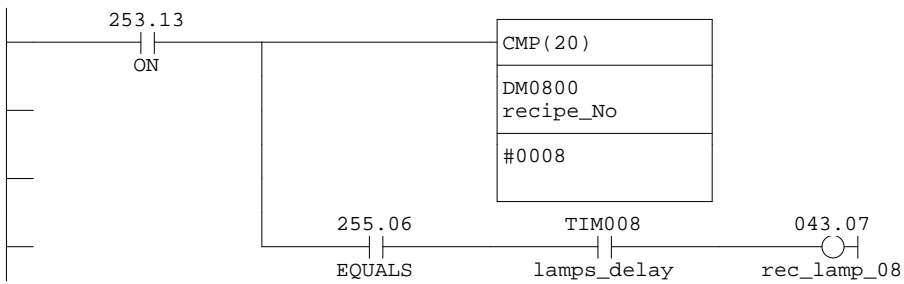
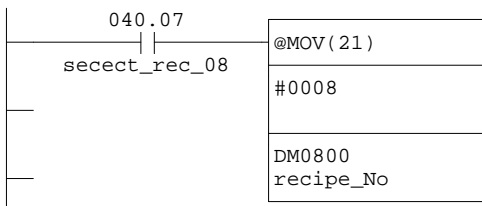
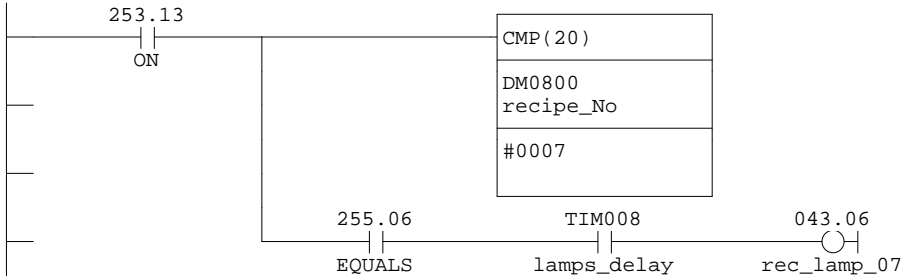
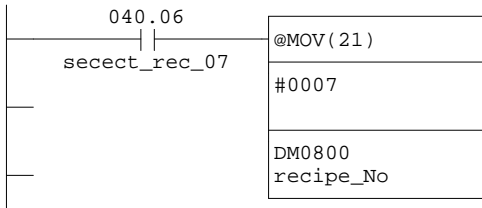



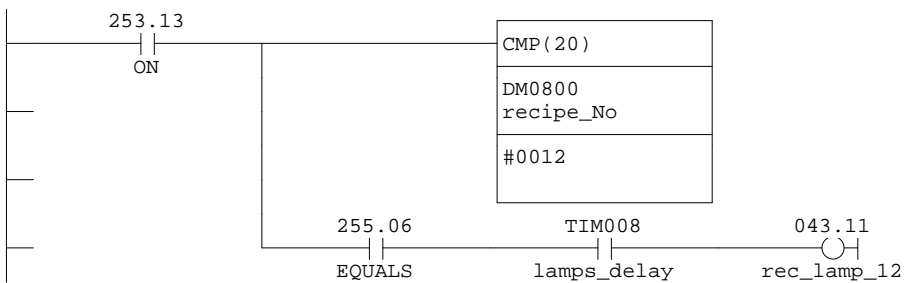
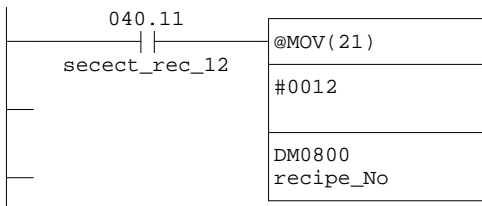
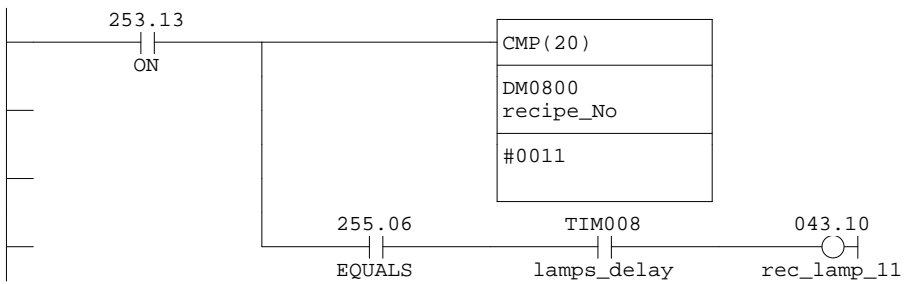
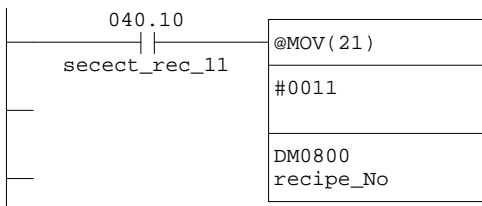
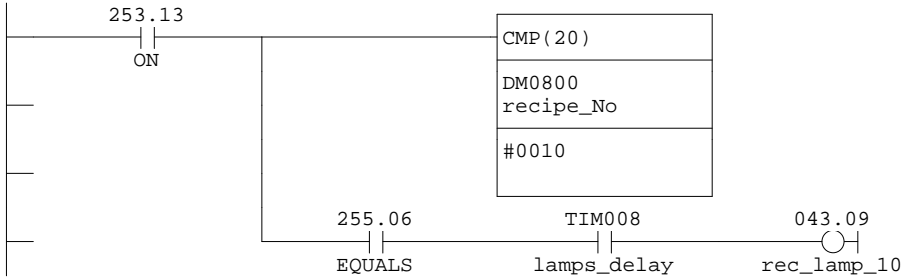
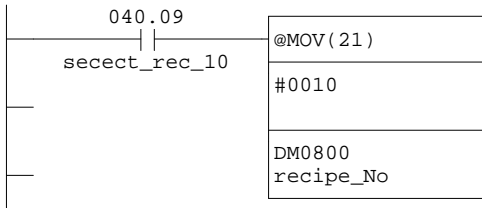

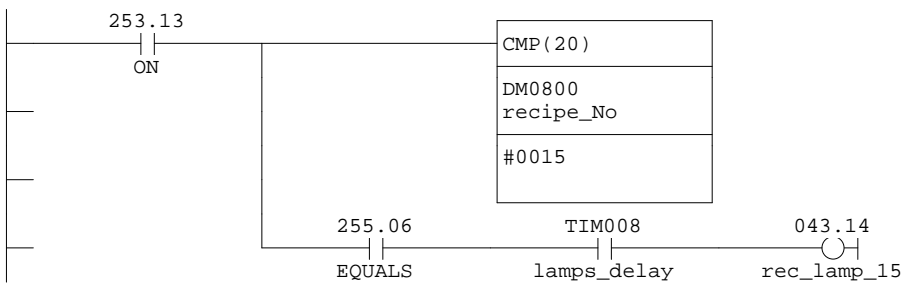
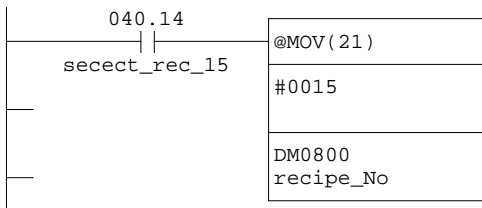
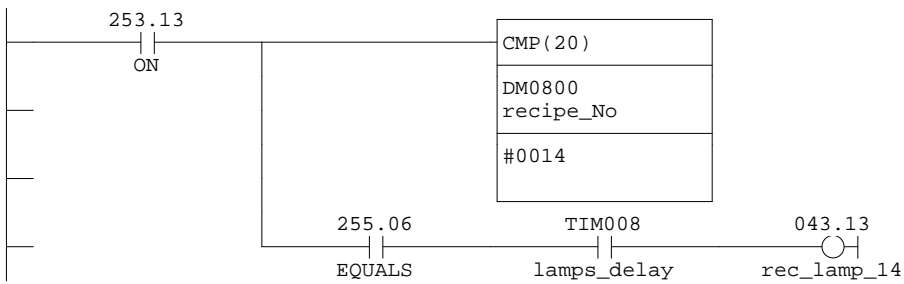
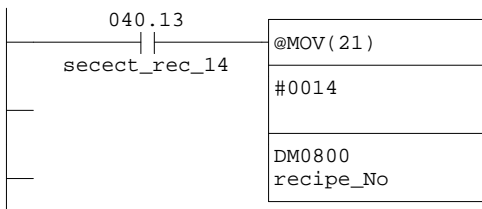
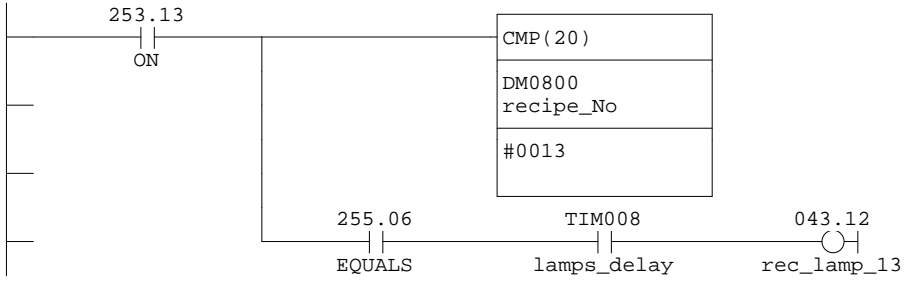
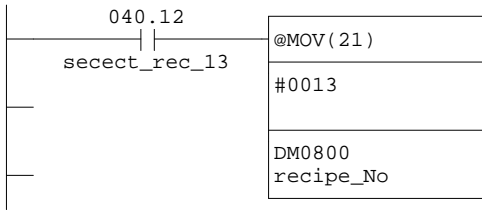

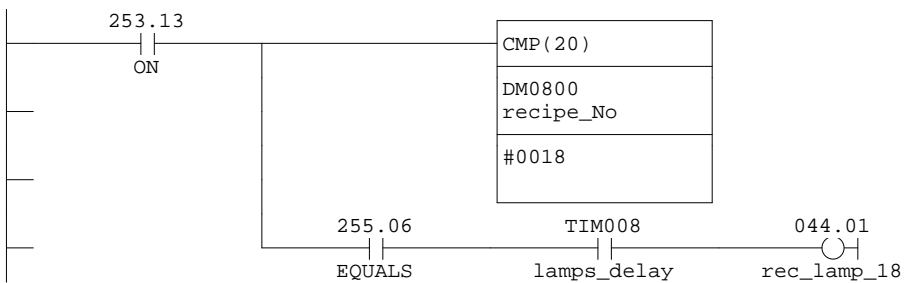
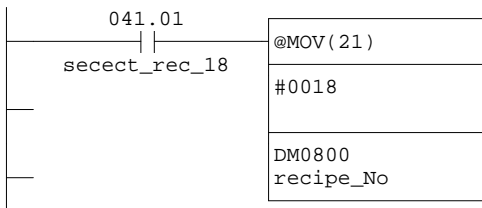
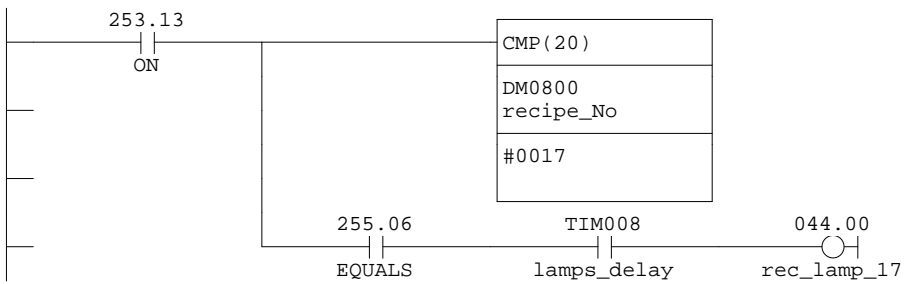
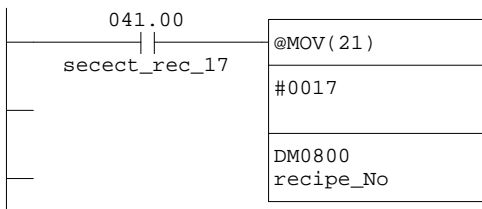
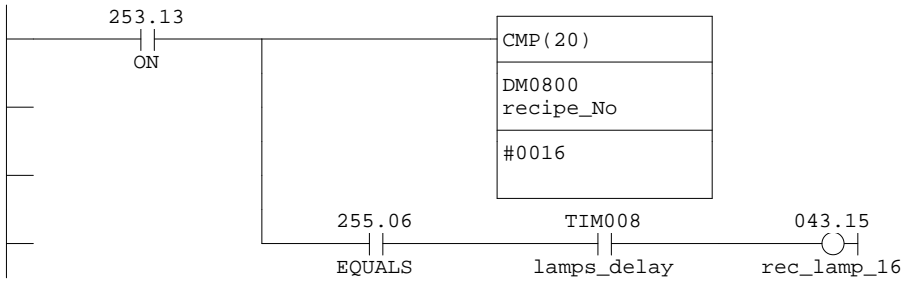
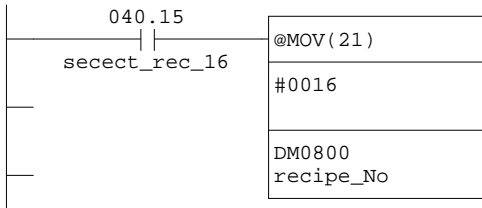

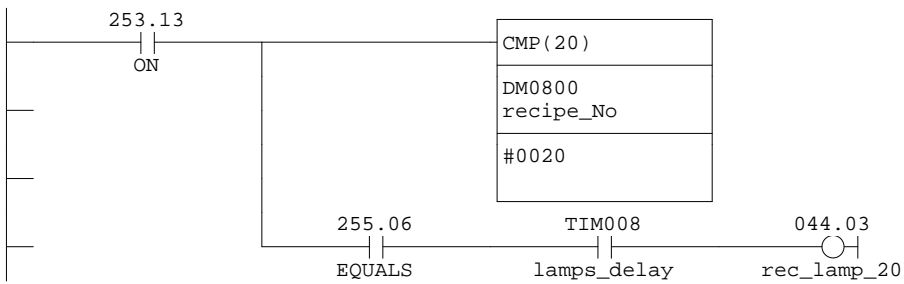
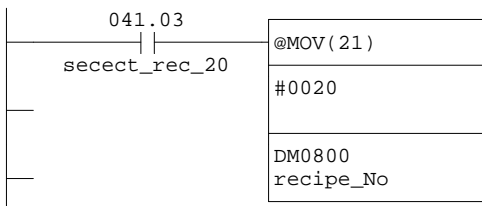
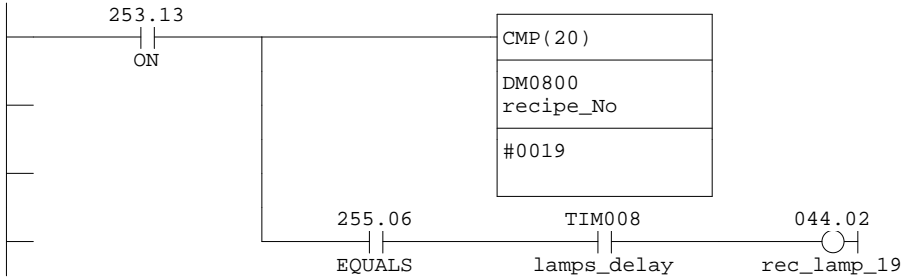
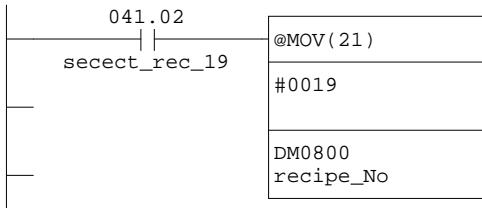

Main 7 - Sel. MCP Resin

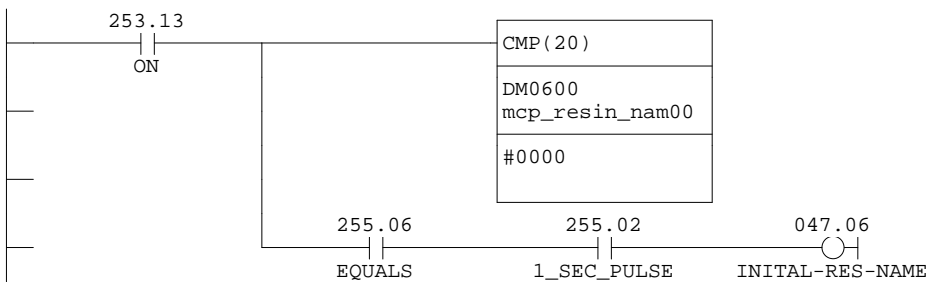

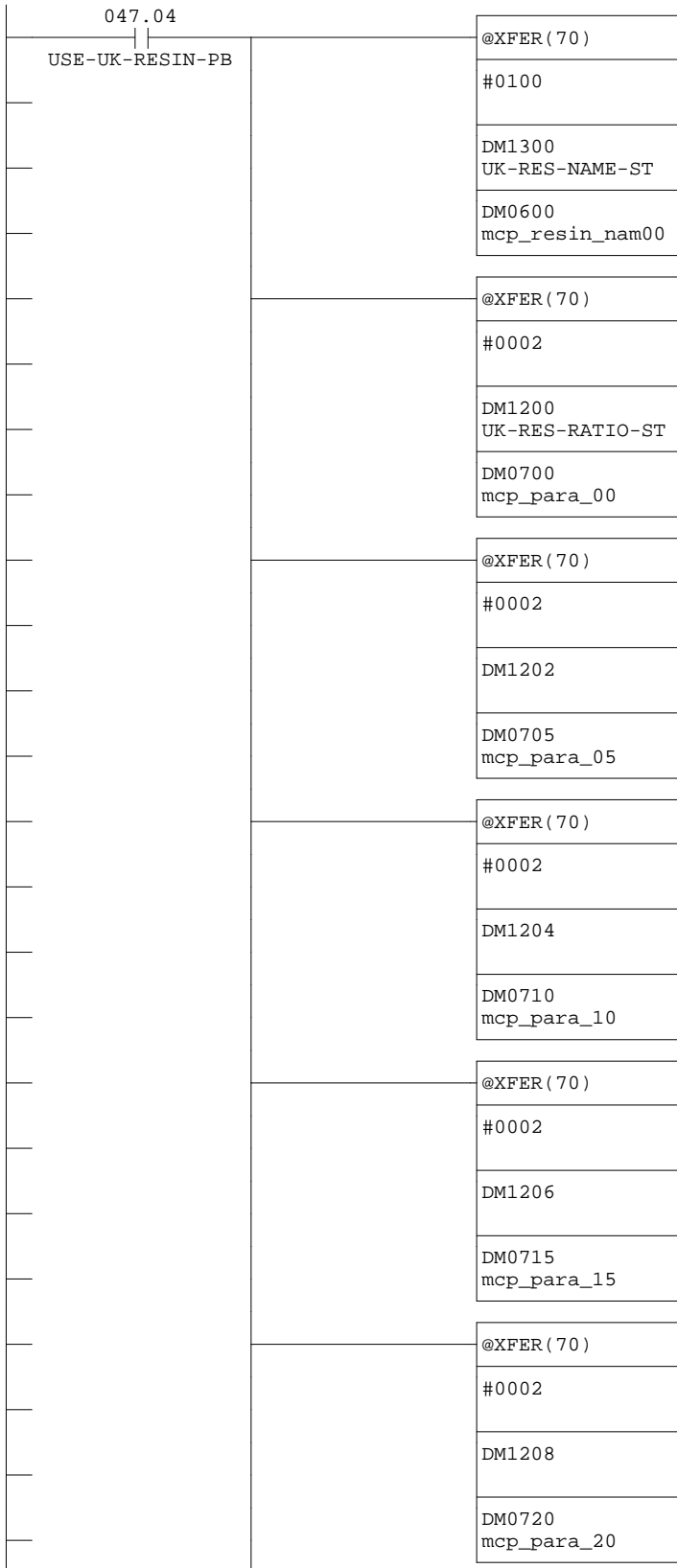

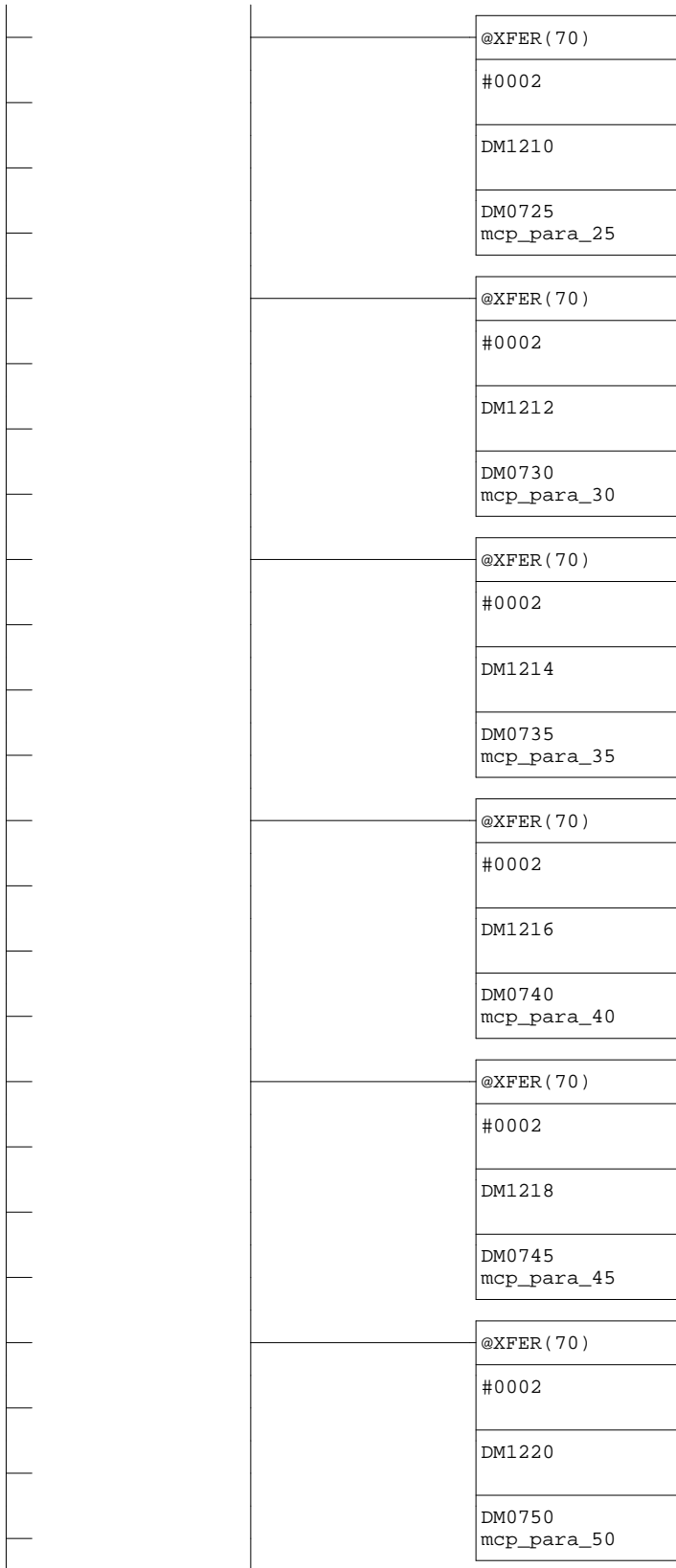

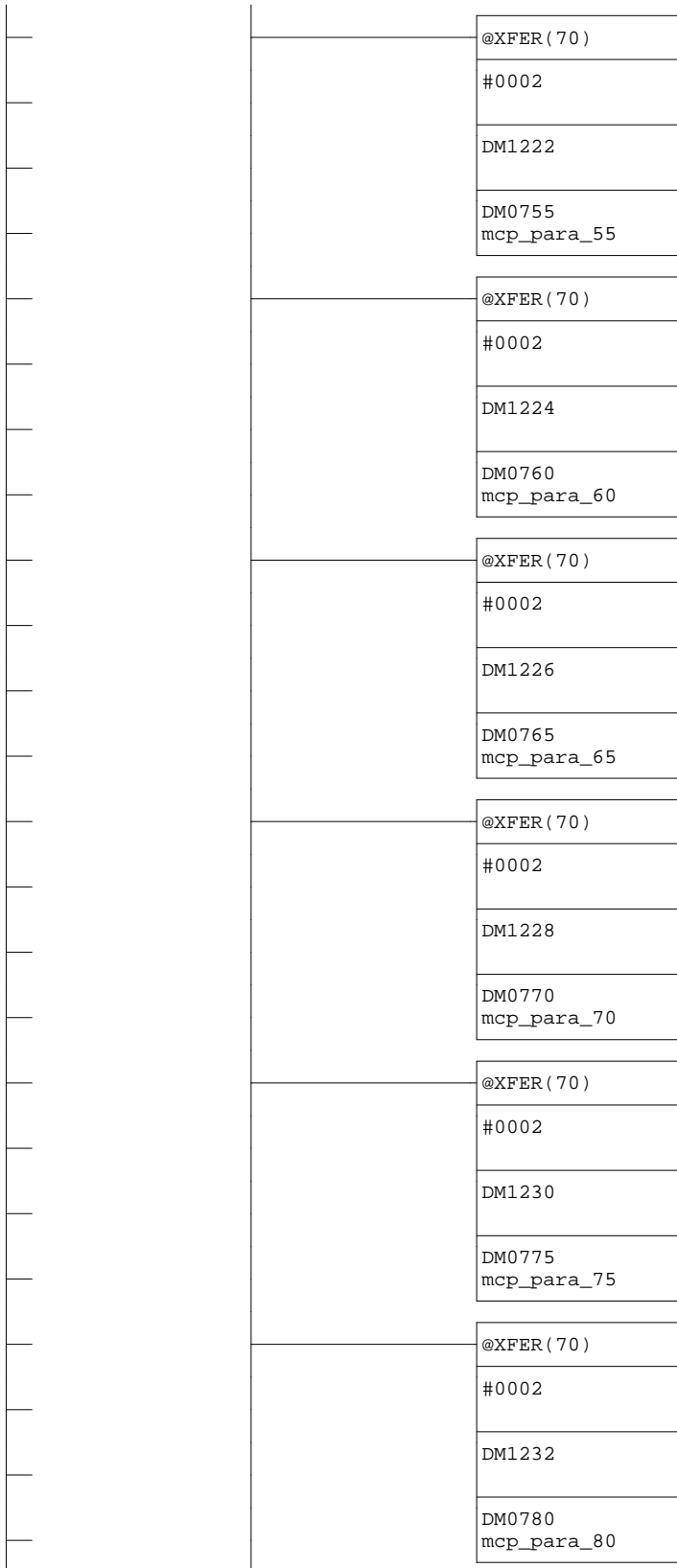

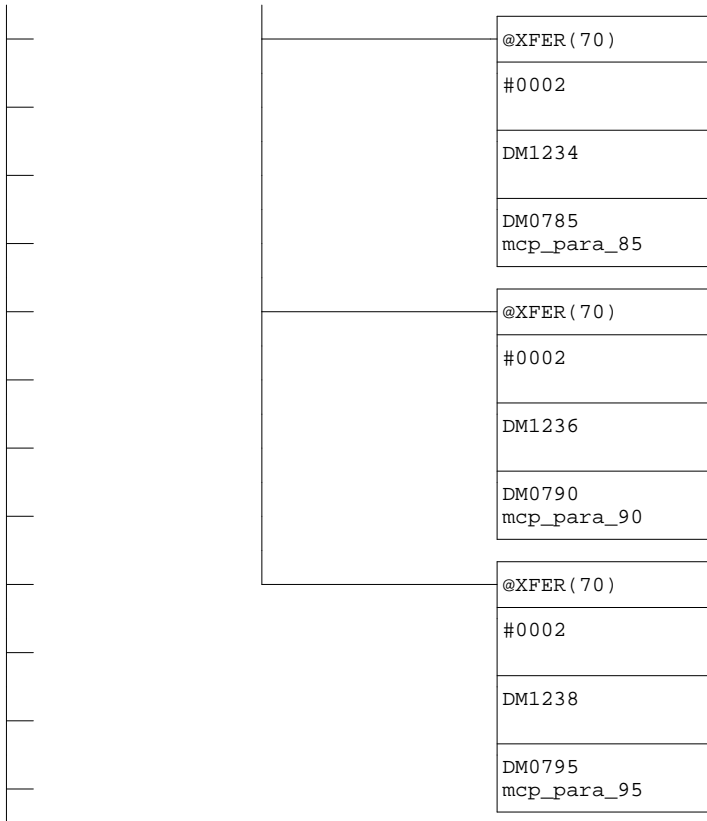



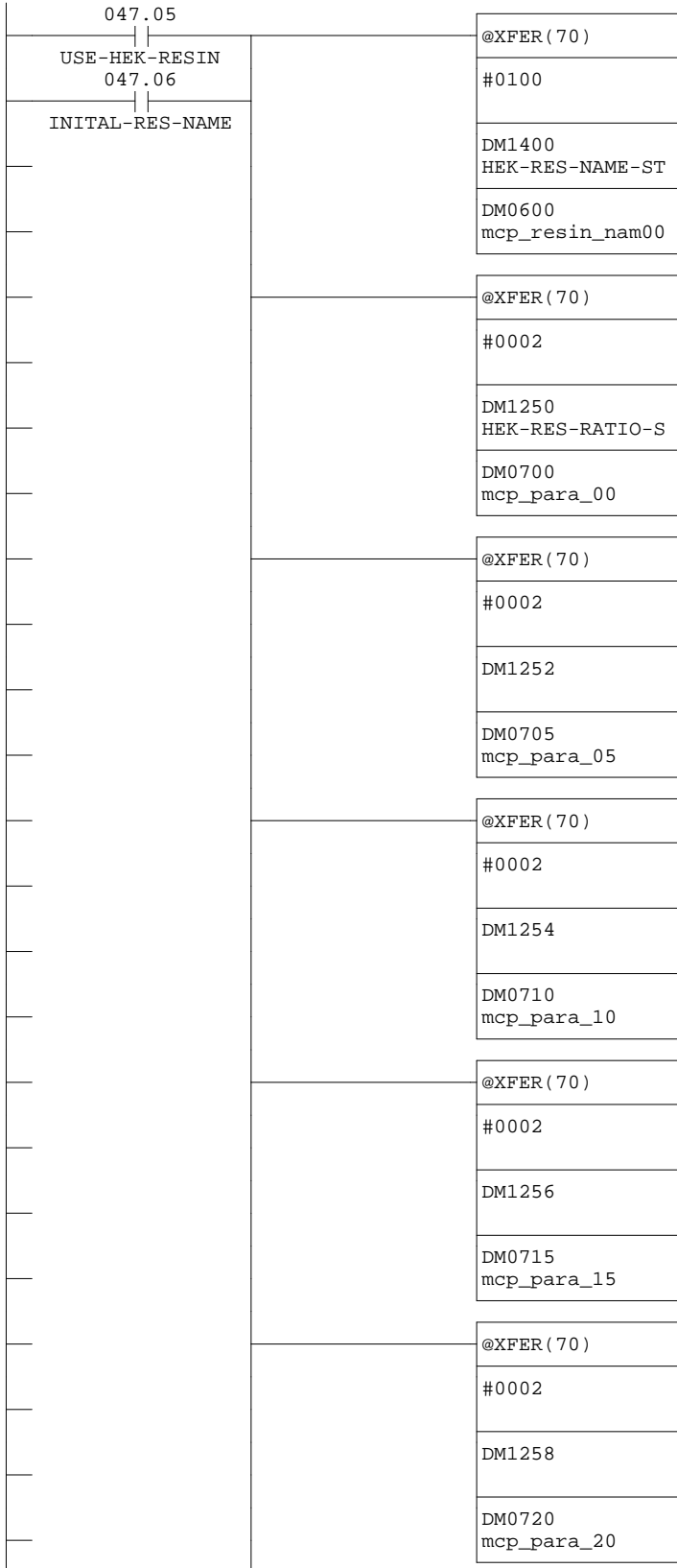

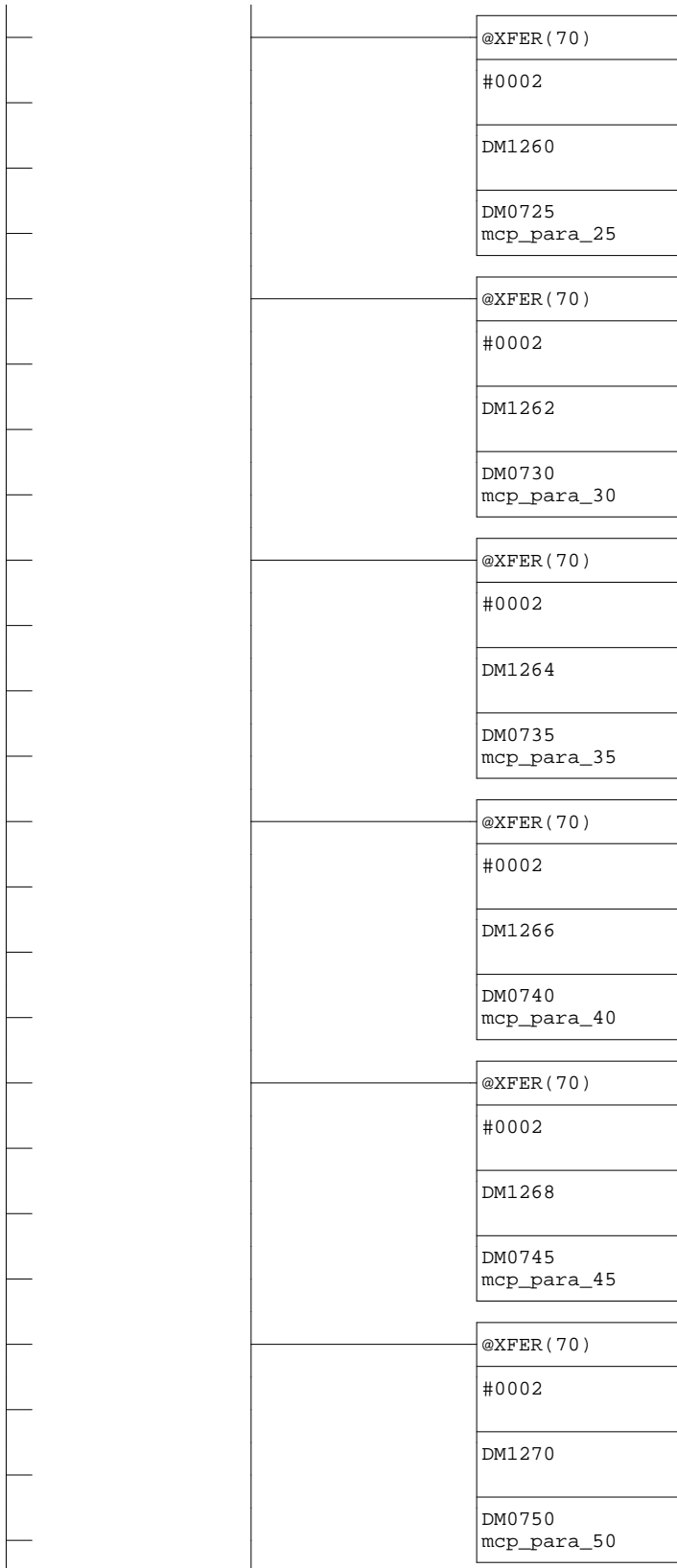

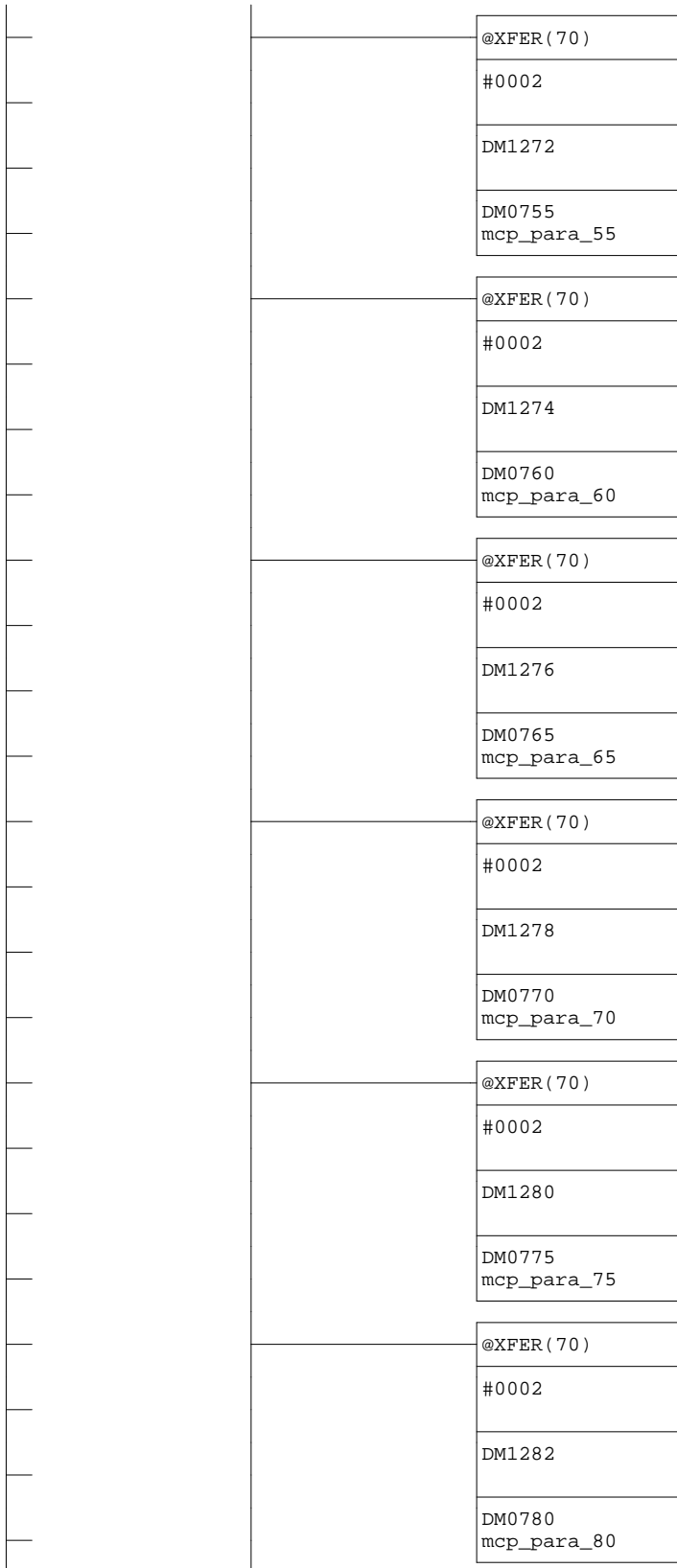

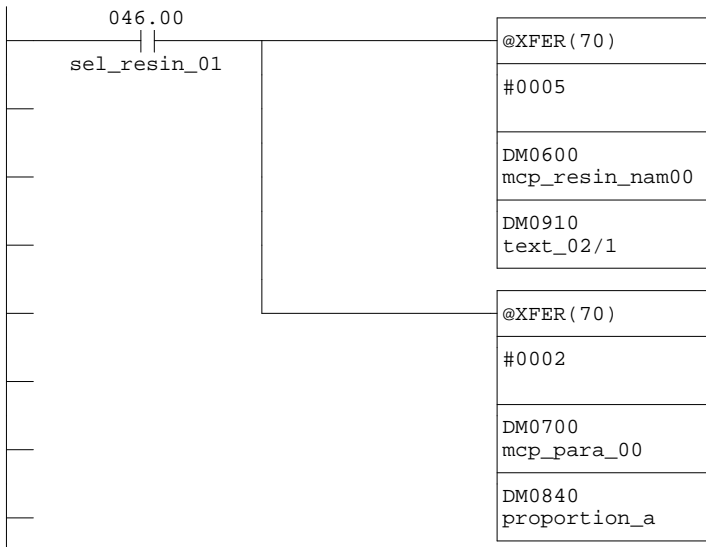

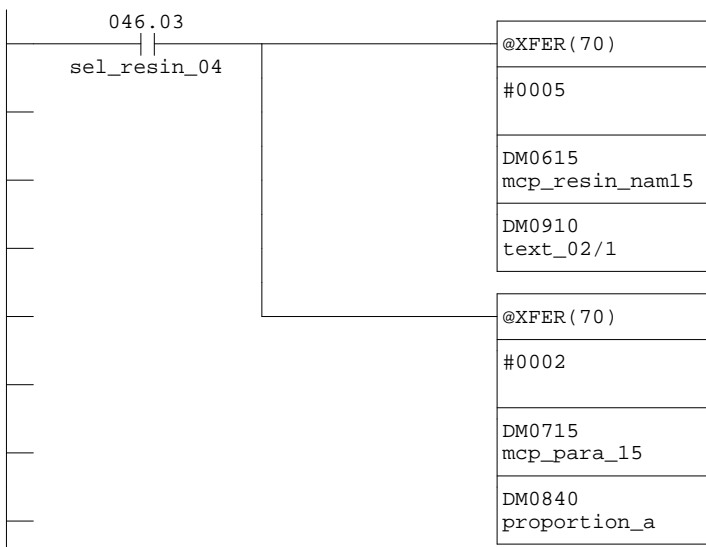
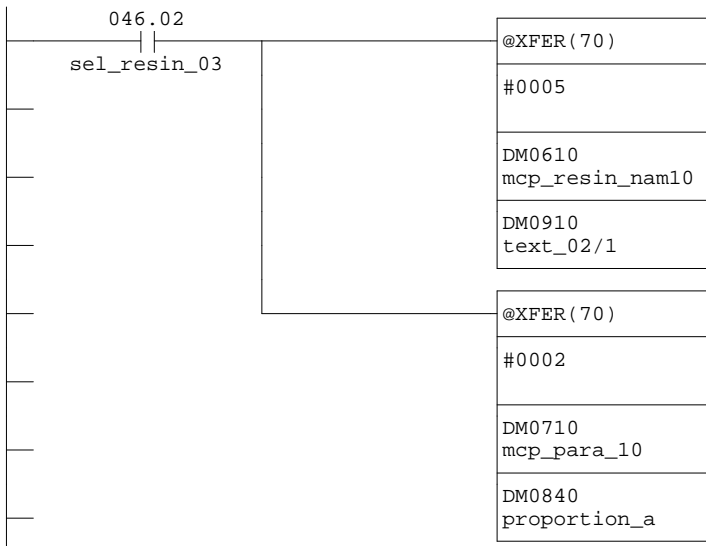
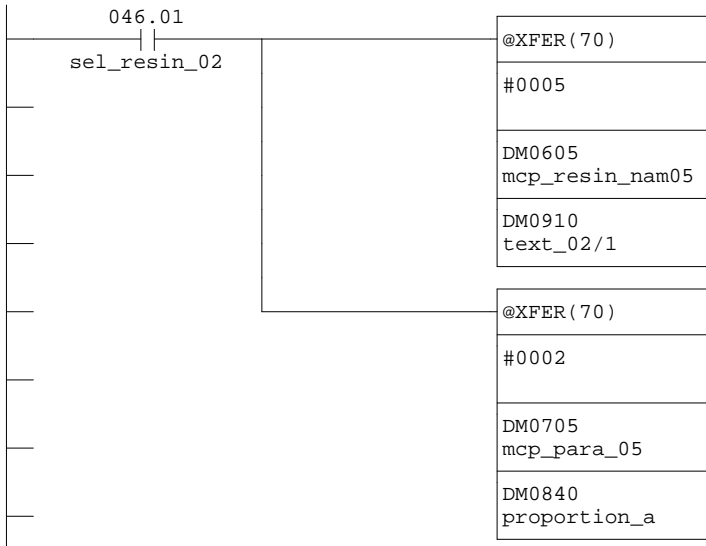

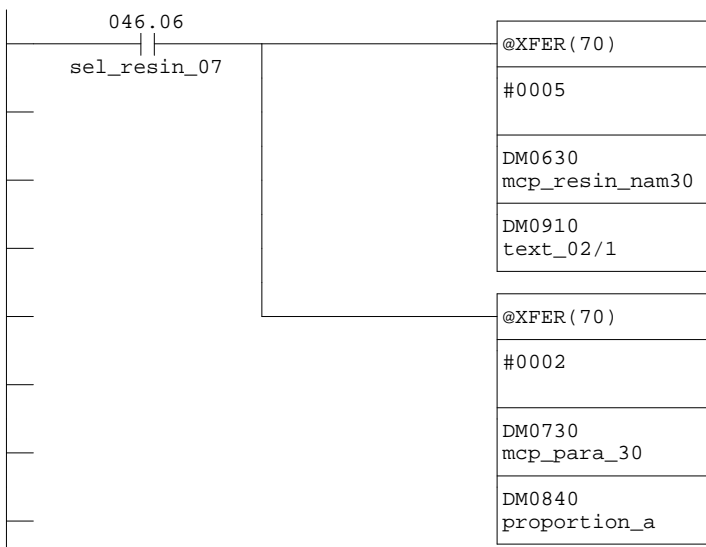
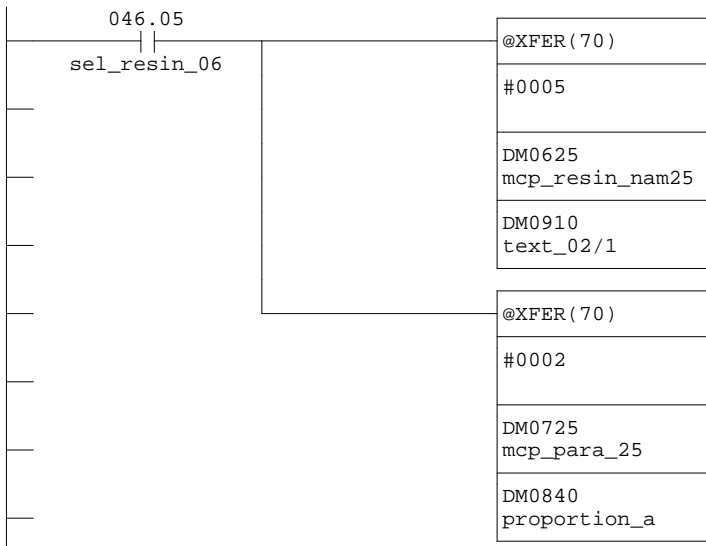
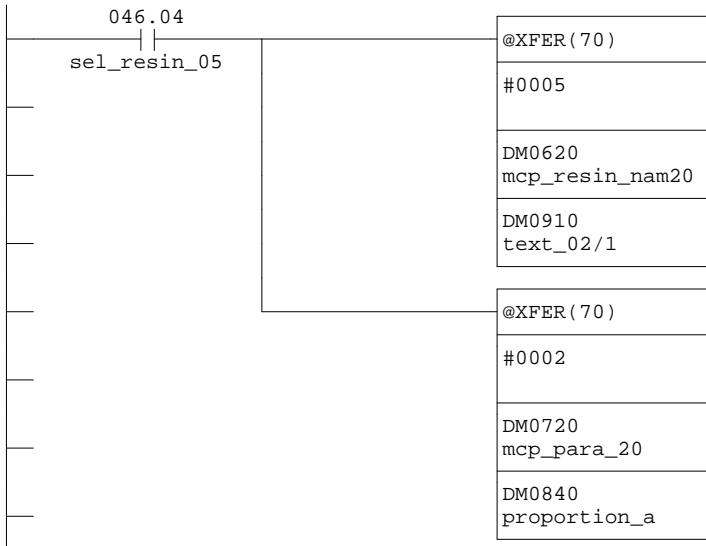

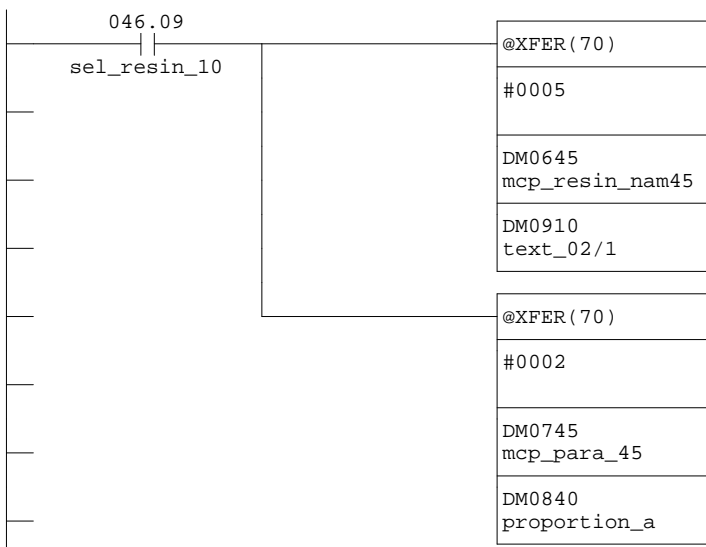
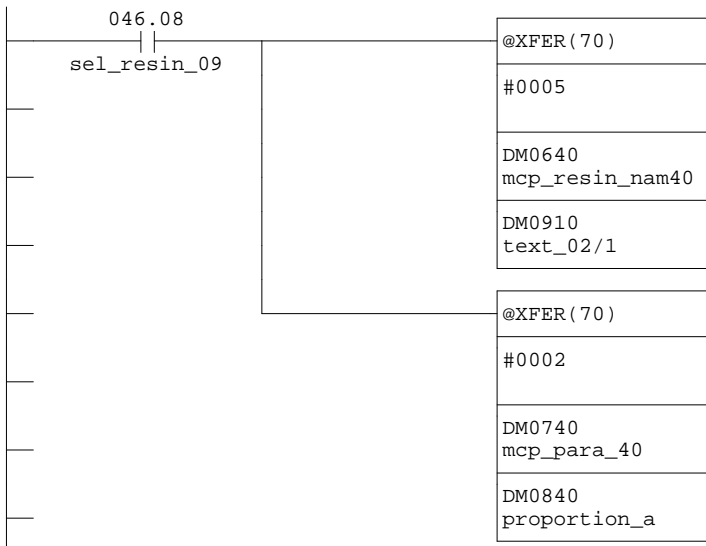
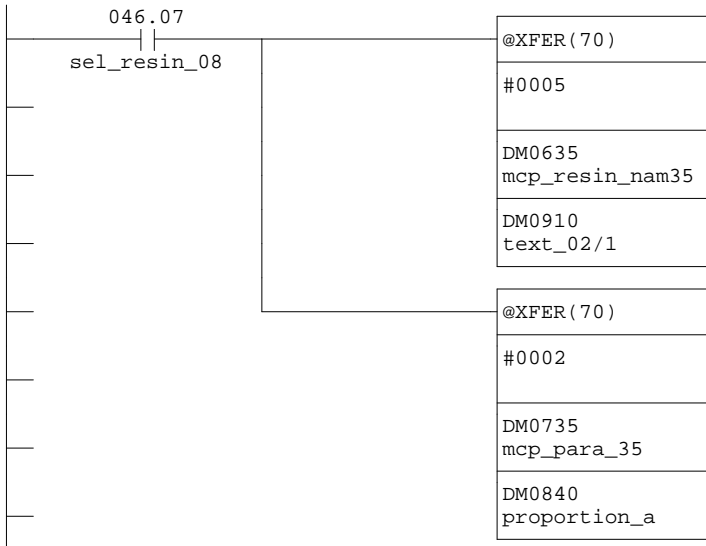

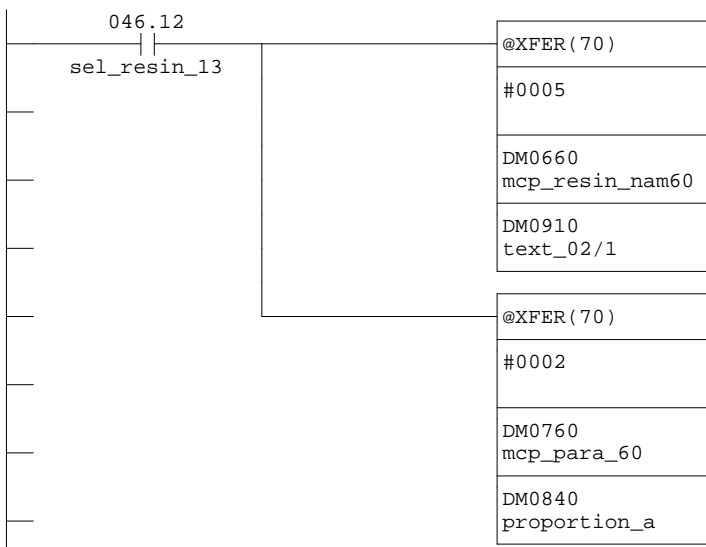
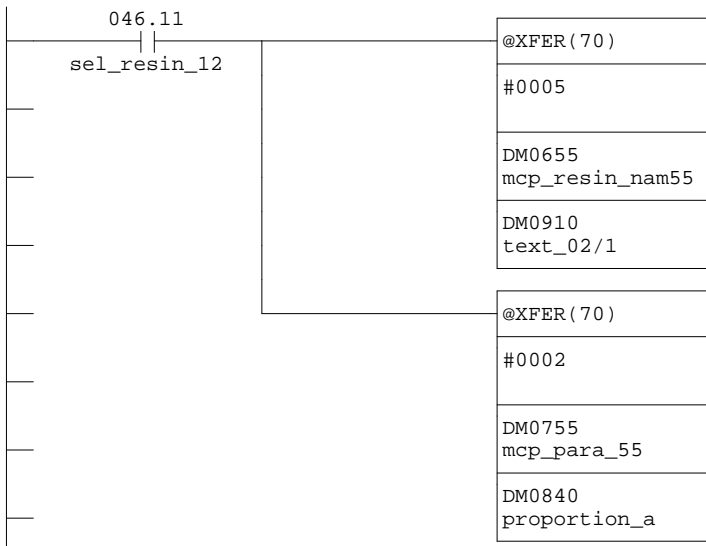
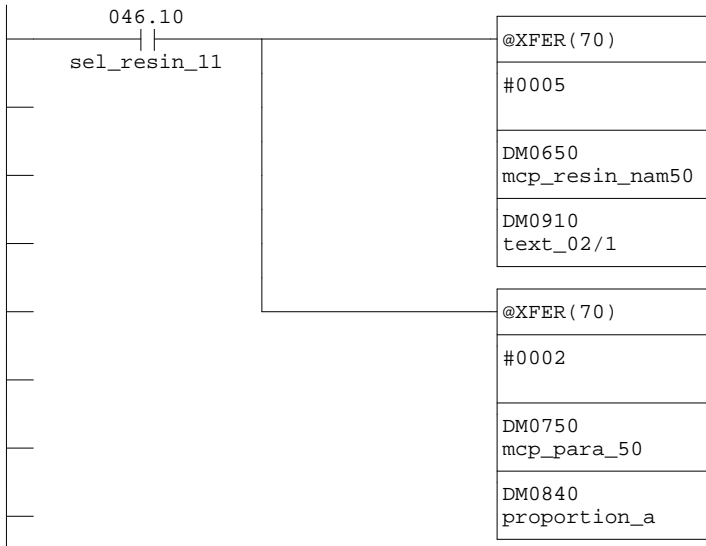



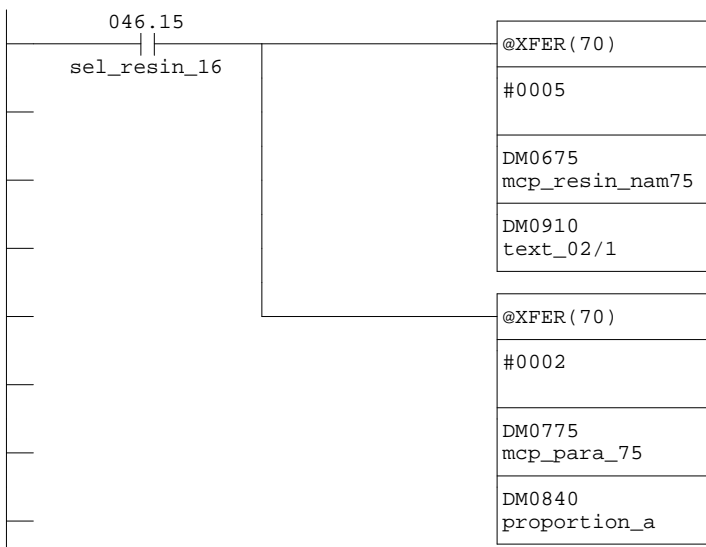
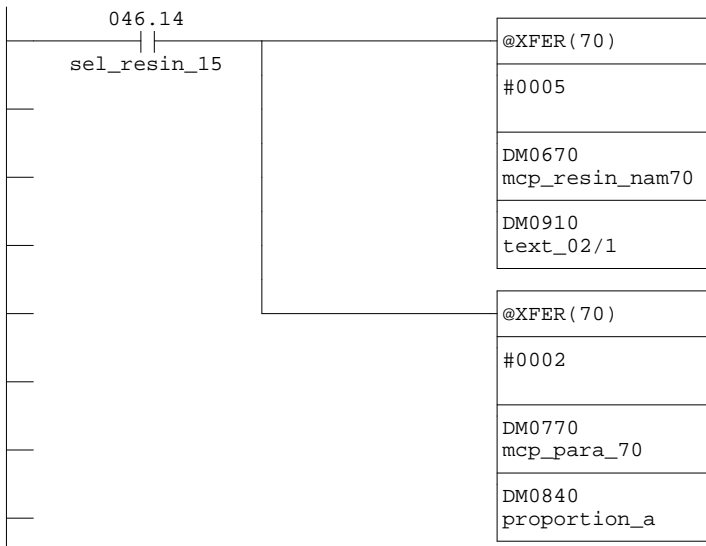
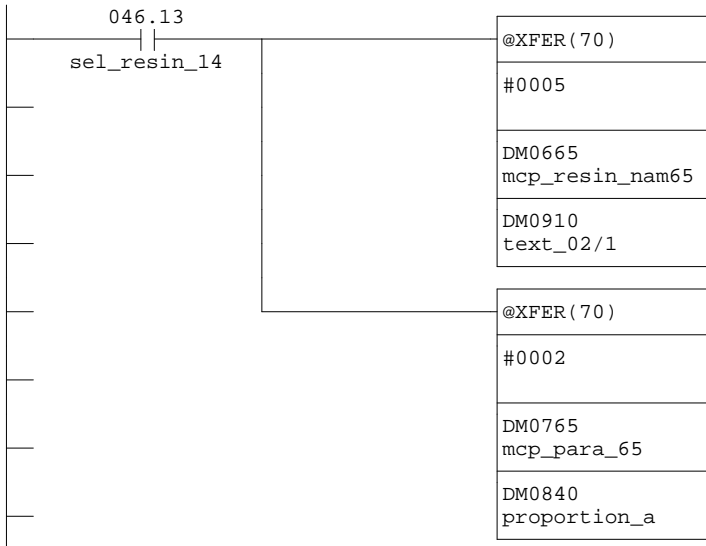

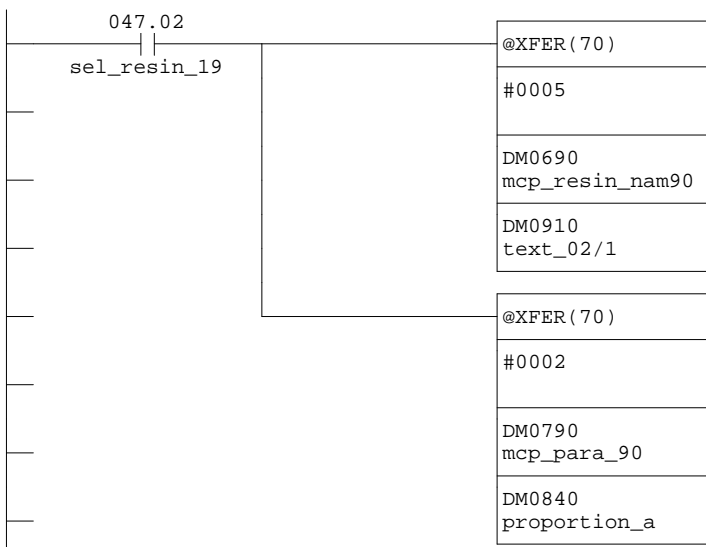
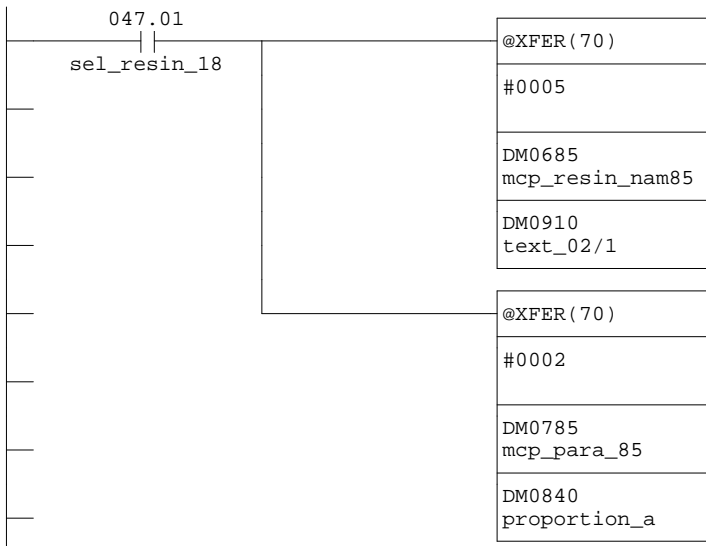
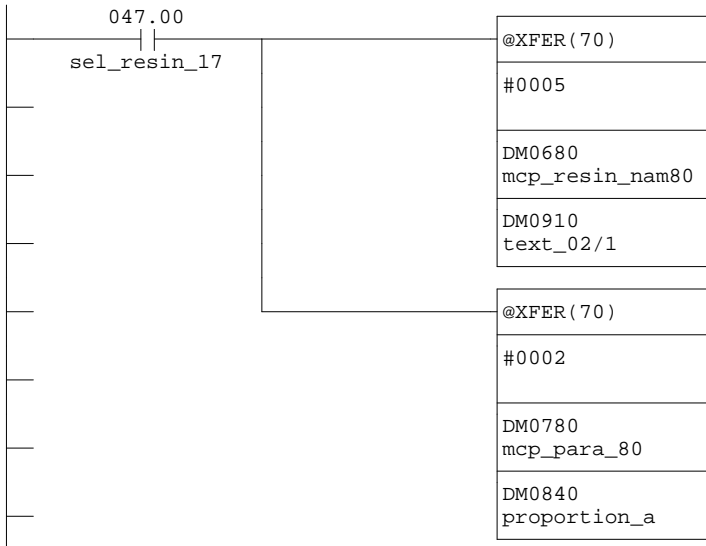

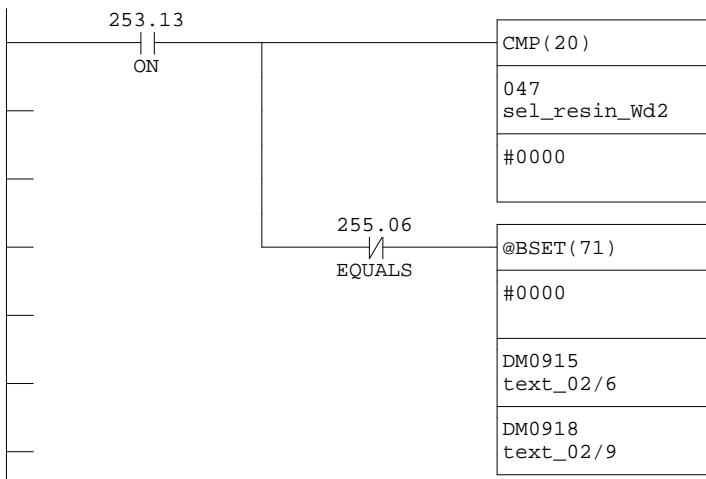
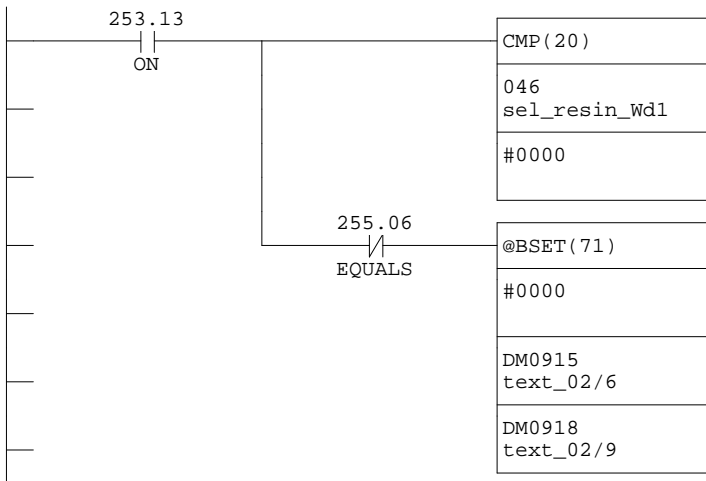
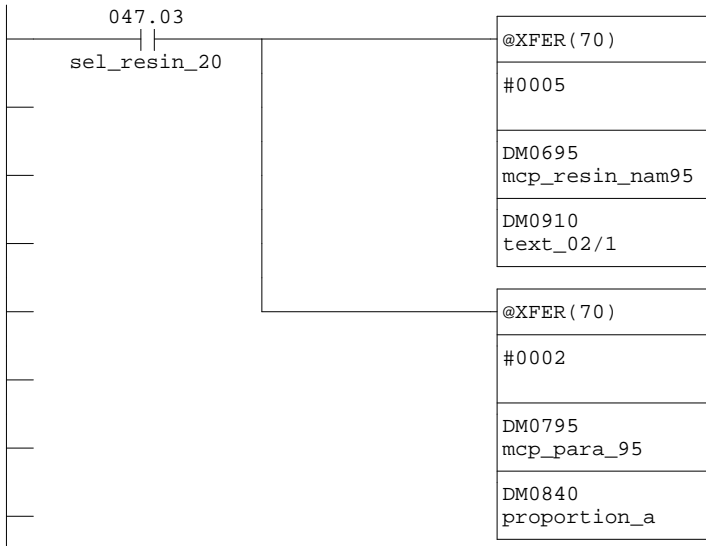

Main 8 - MCP weights

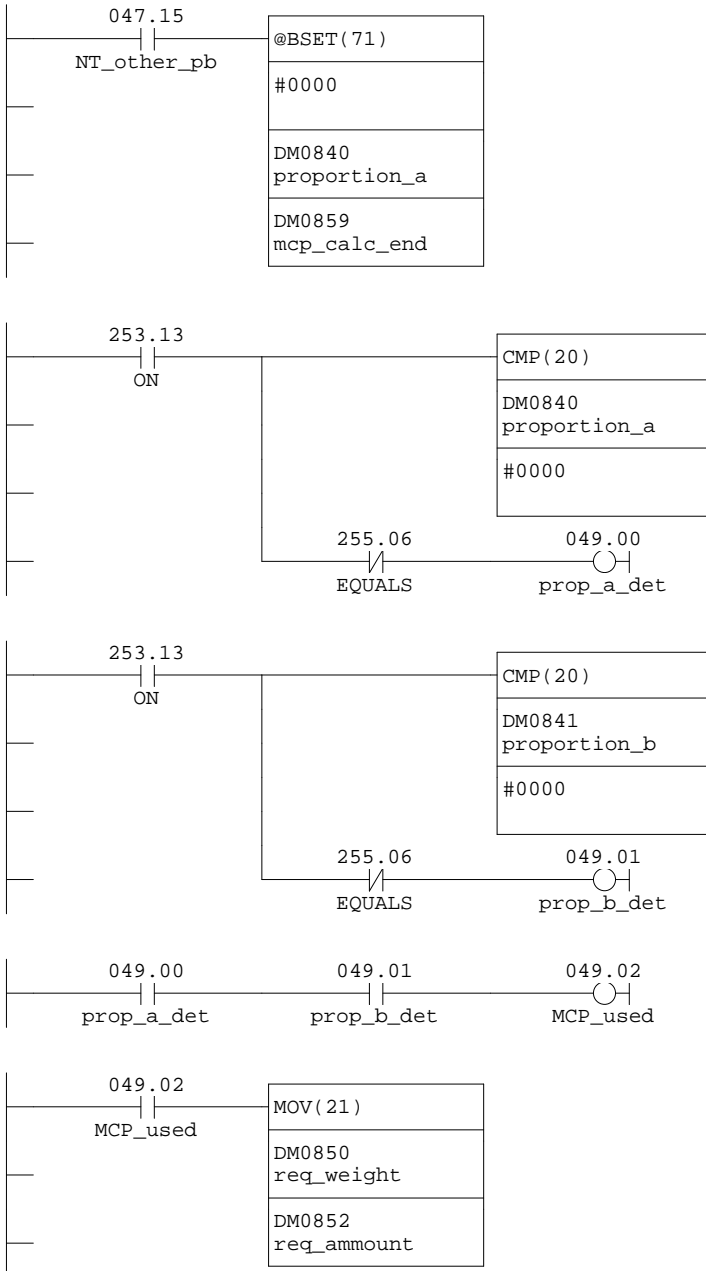

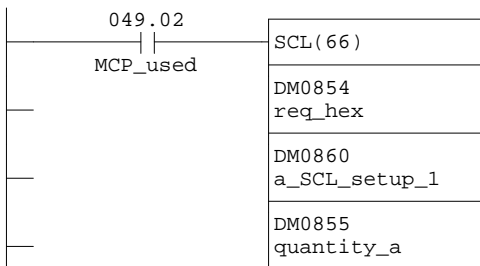
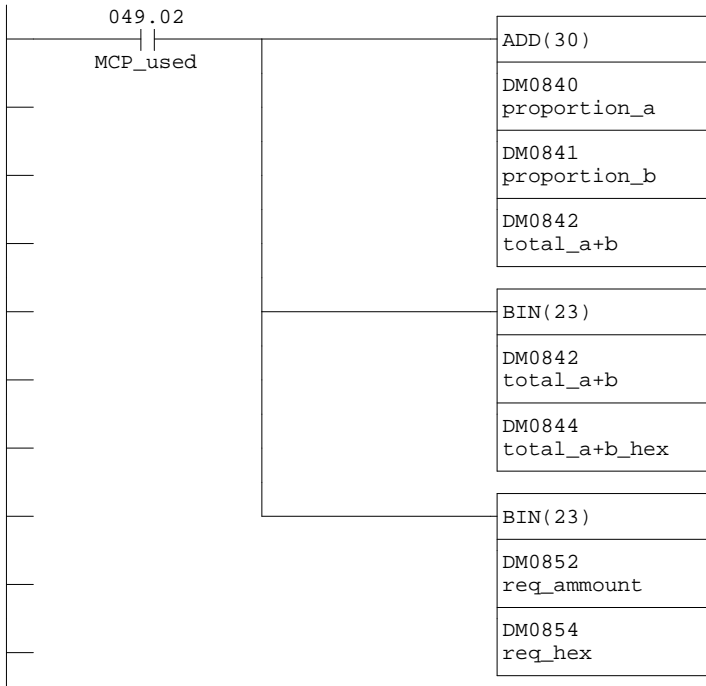

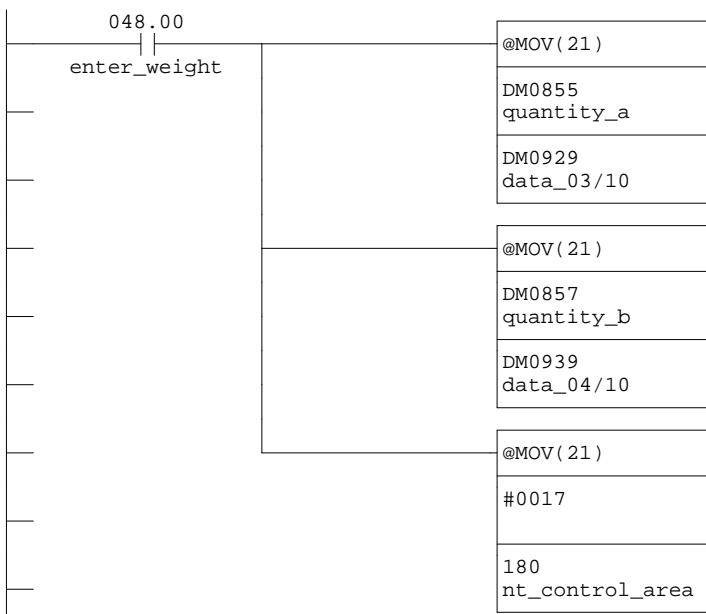
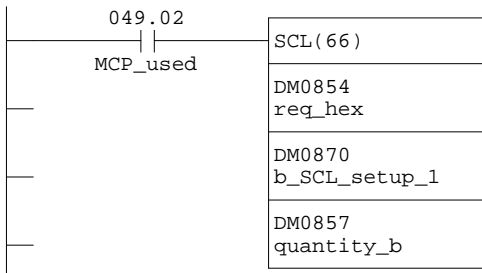

Main 9 - Text edit word

Network 1 - Clear edit wd.

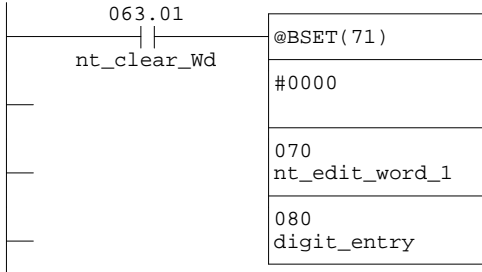

Network 2 - Accept TEMP.

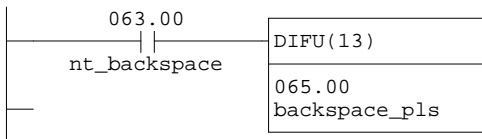
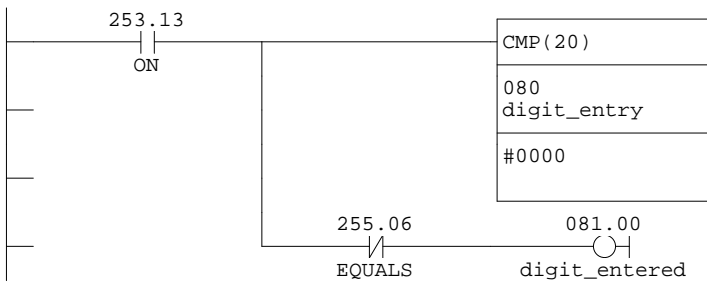
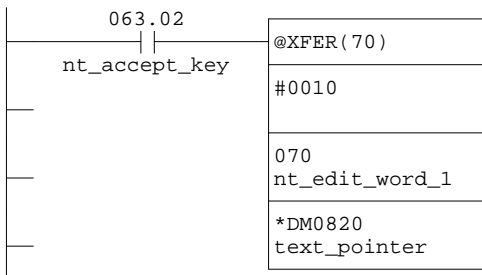

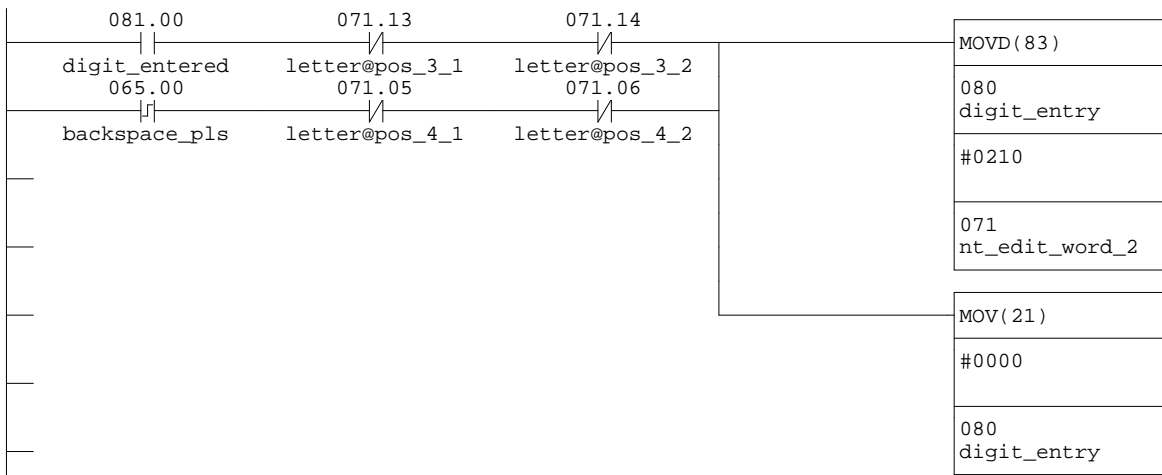
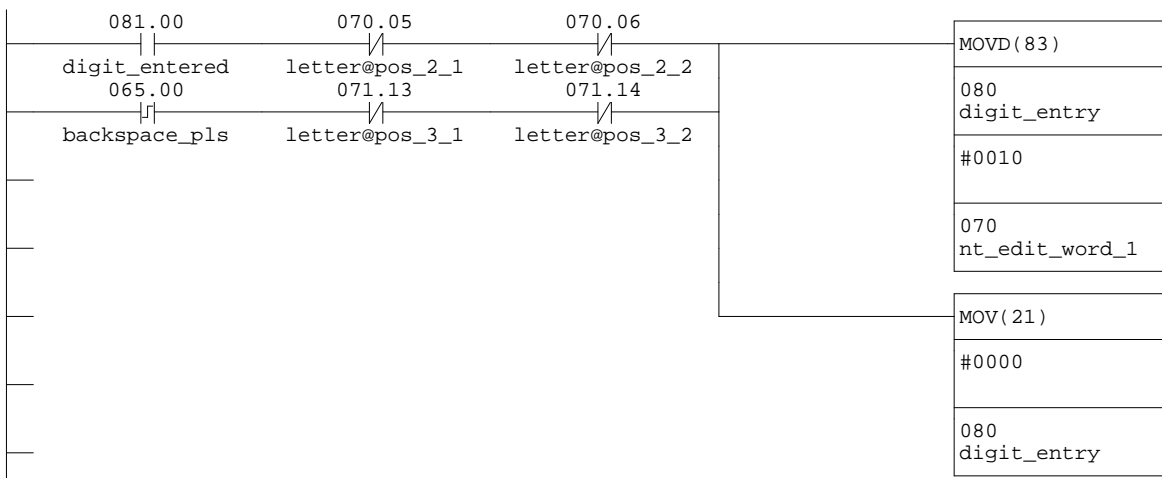
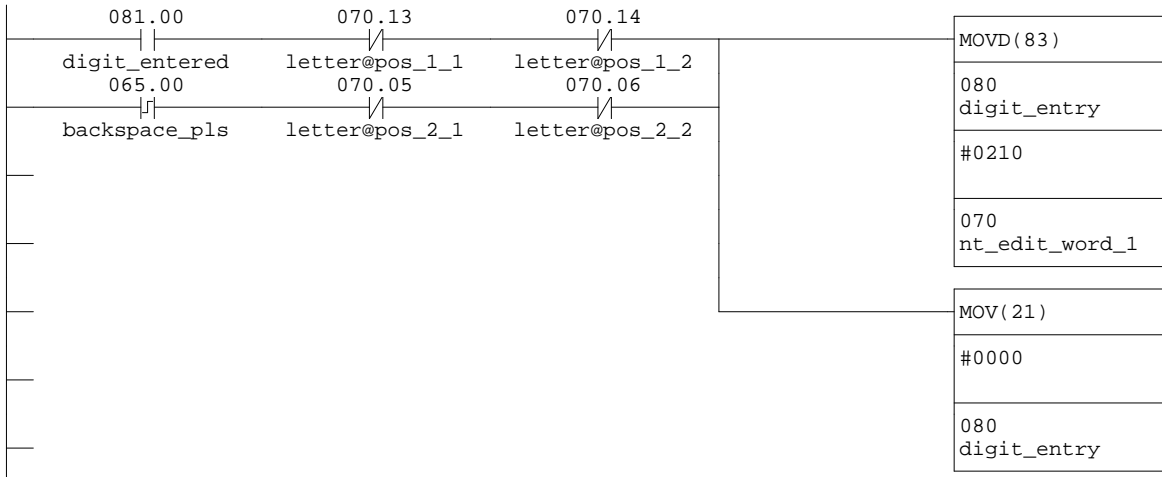



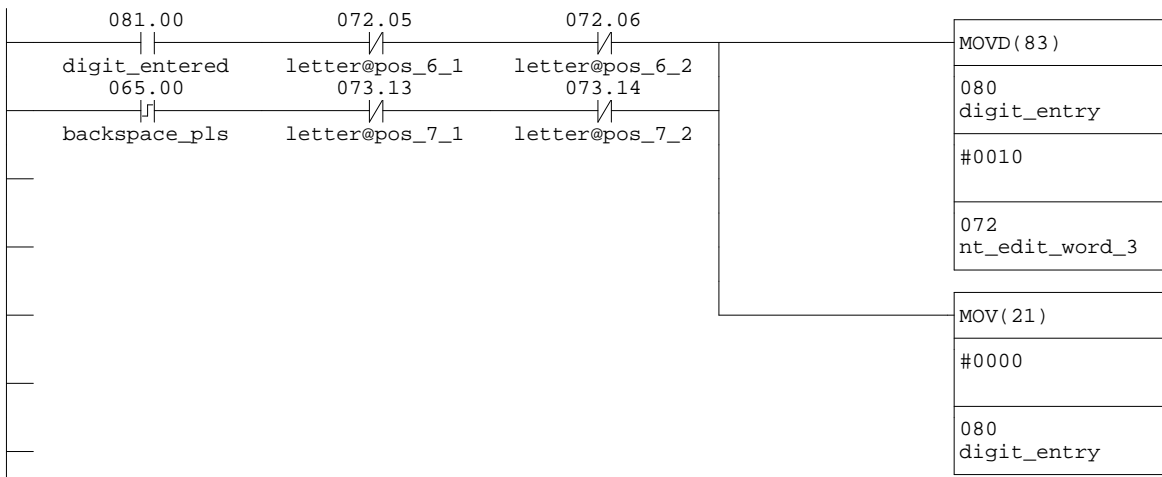
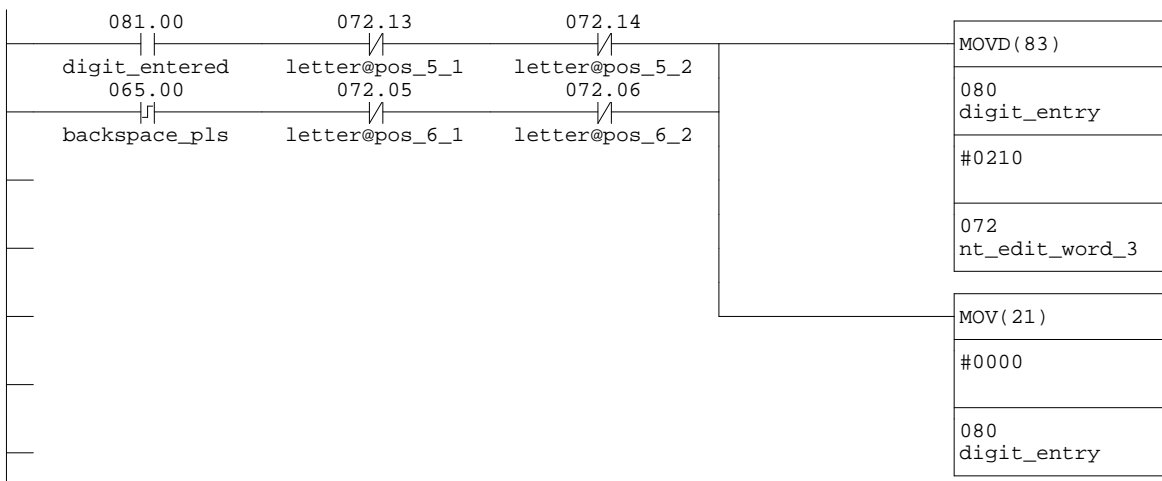
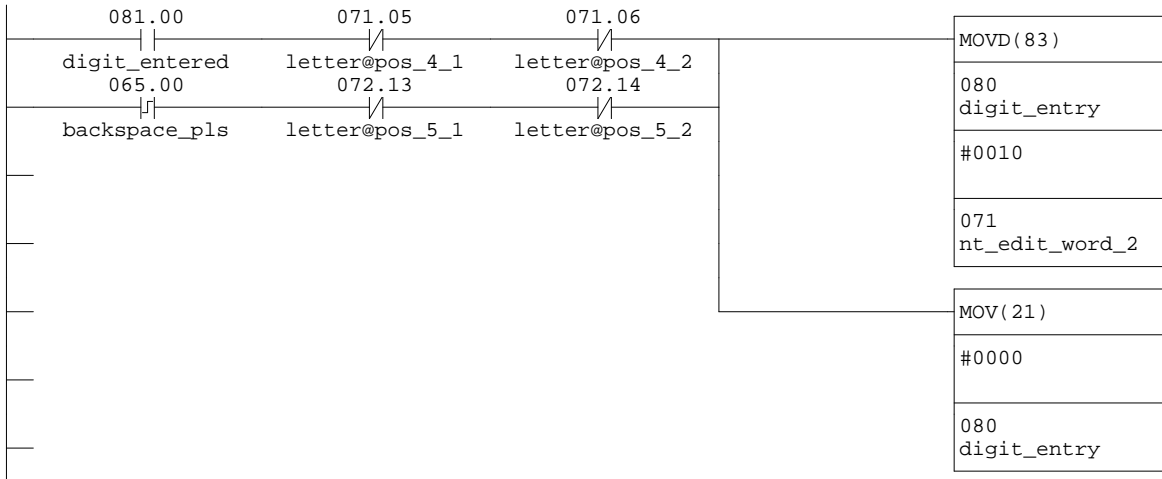

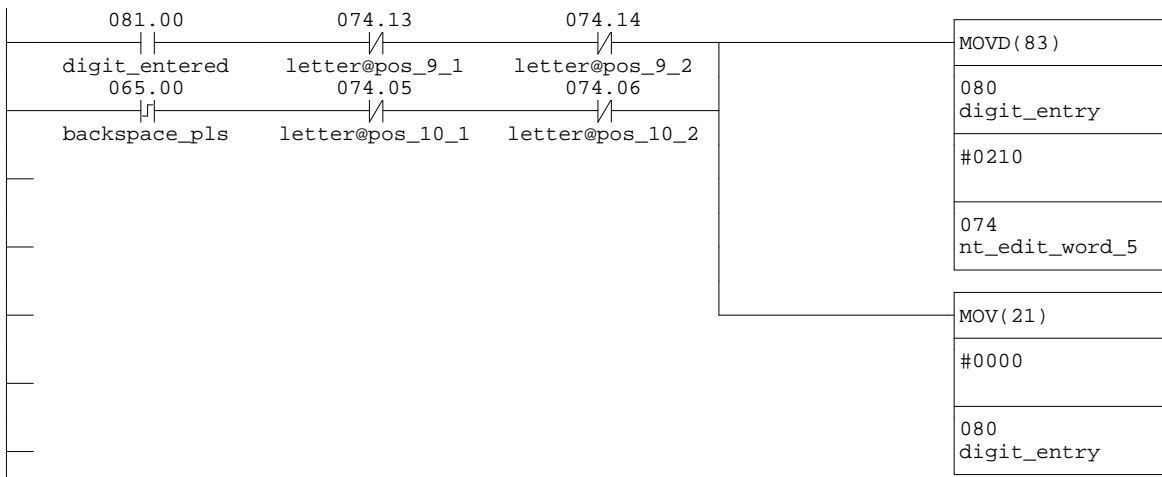
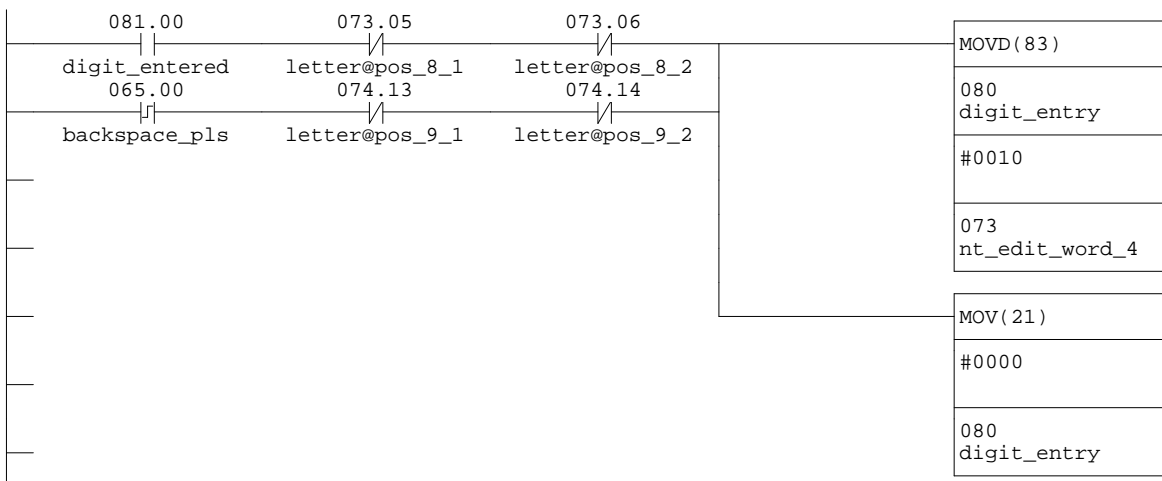
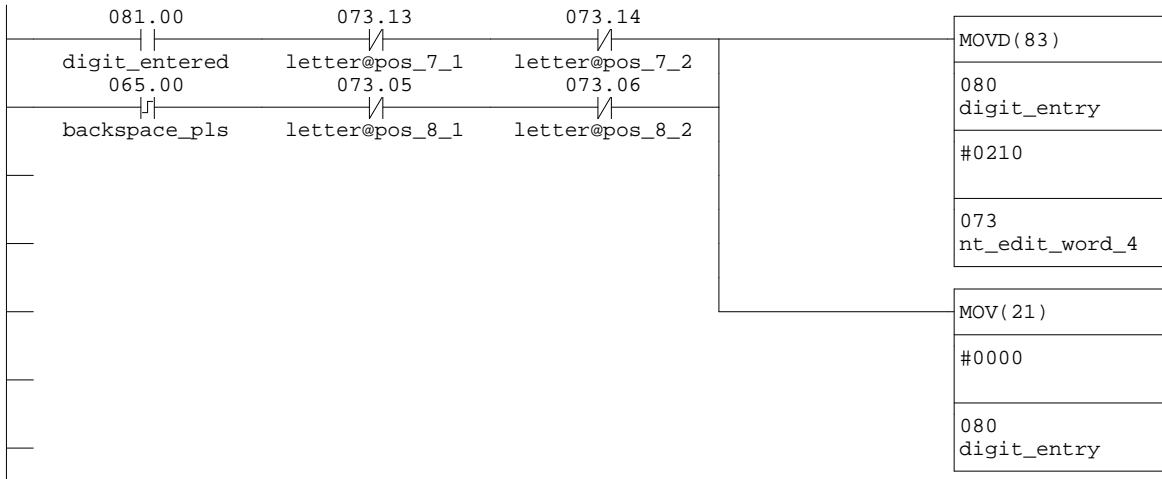

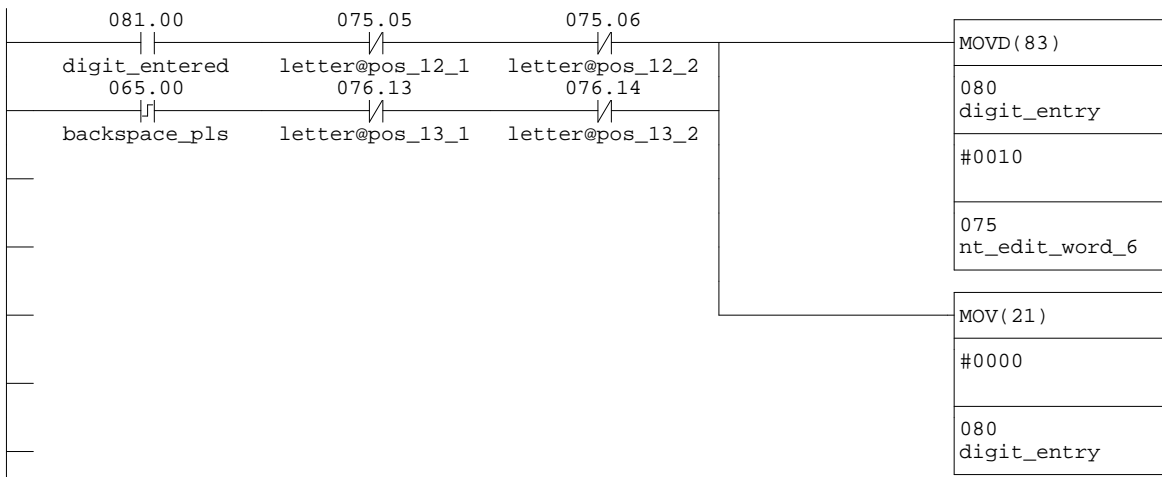
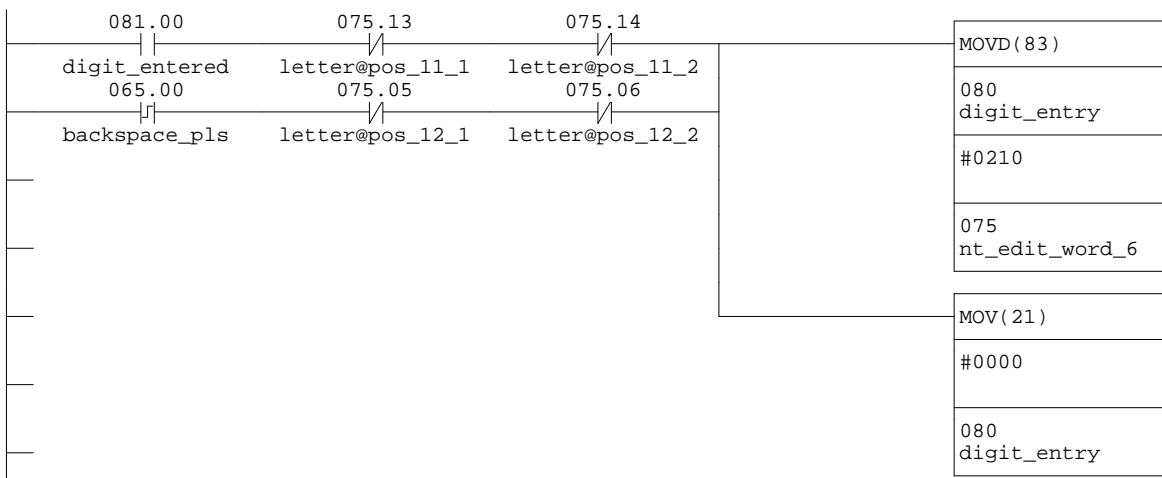
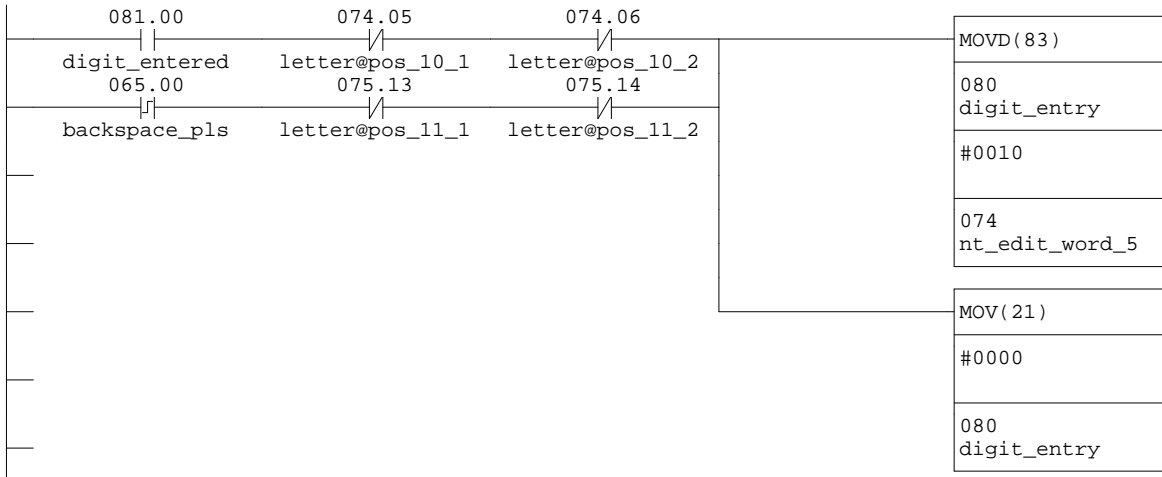

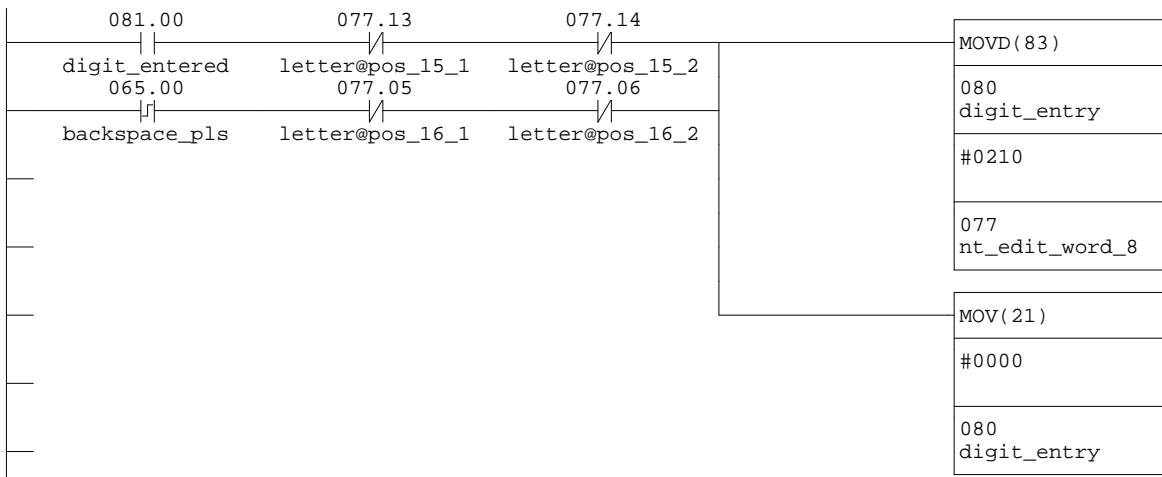
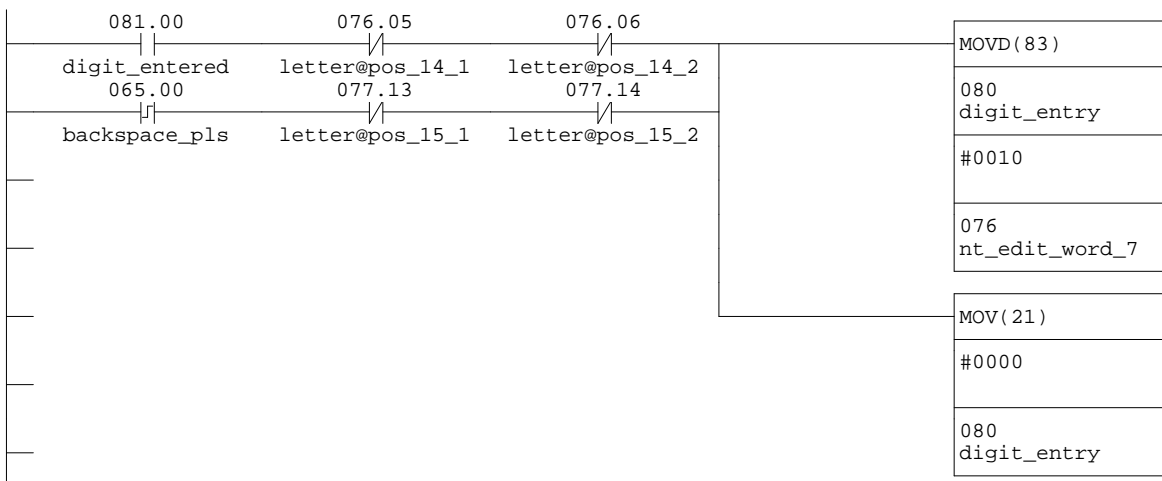
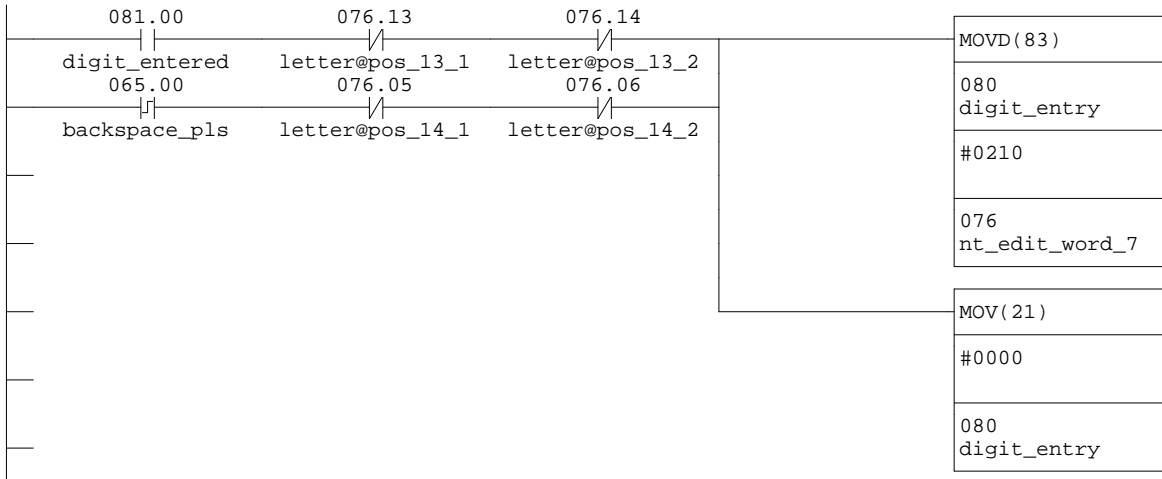

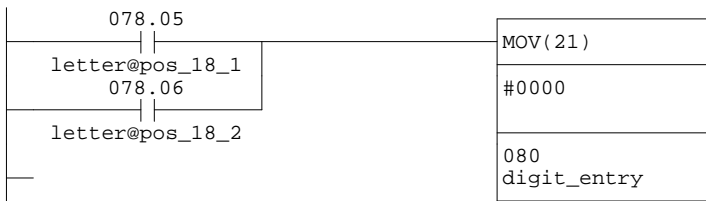
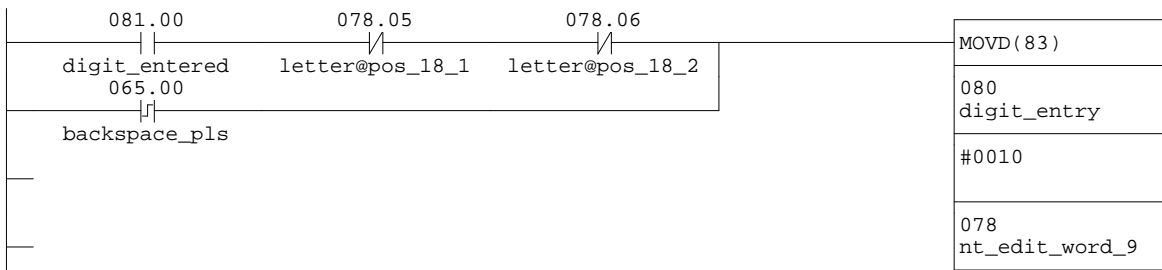
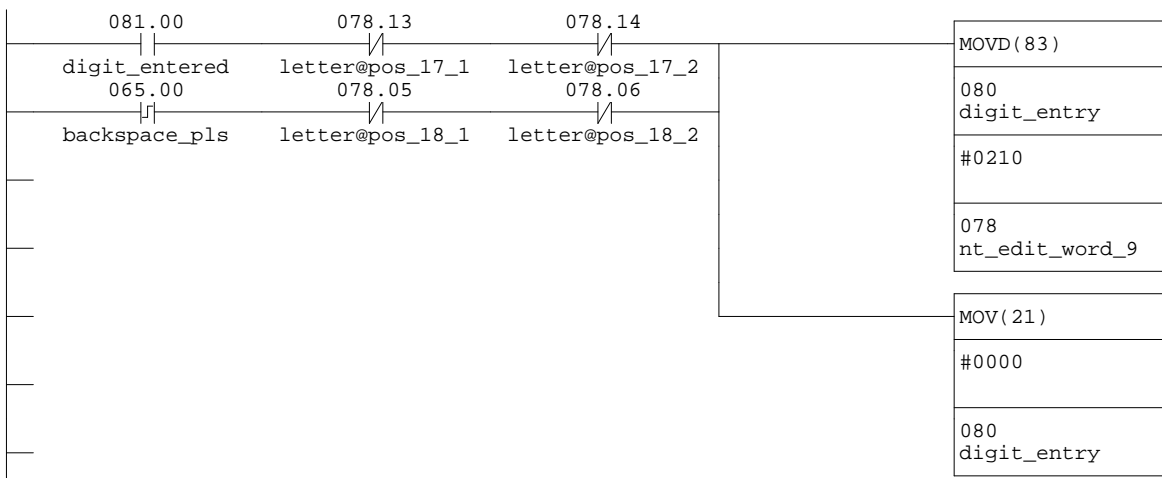
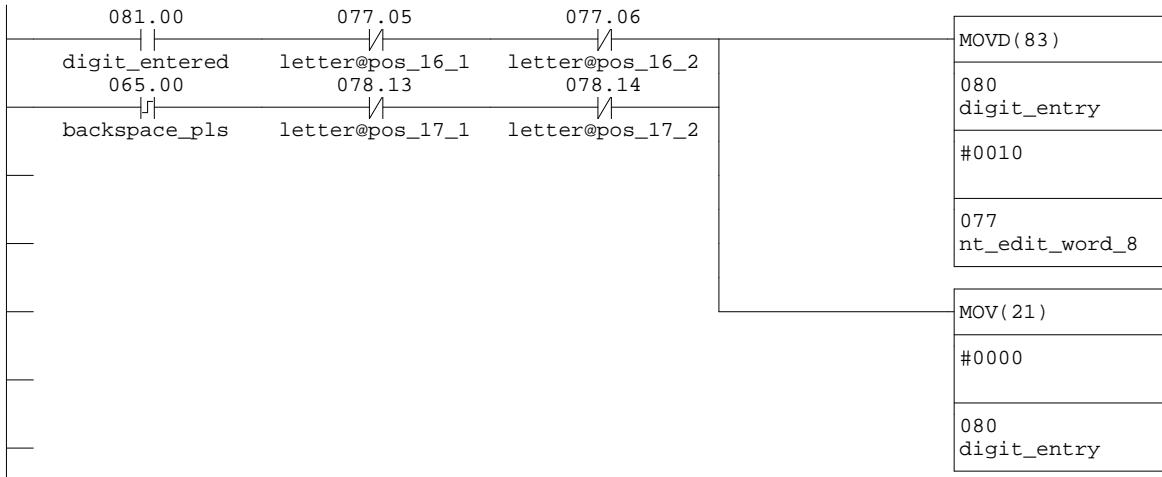

Network 24 - Enter letters

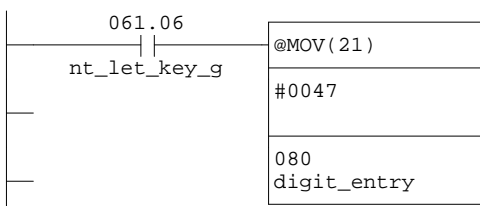
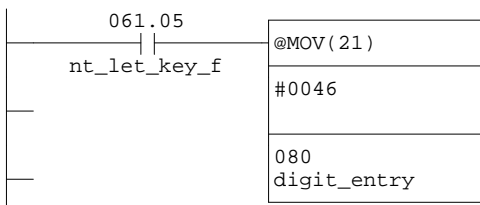
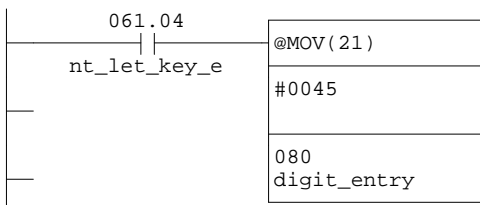
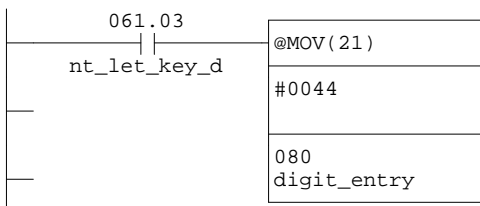
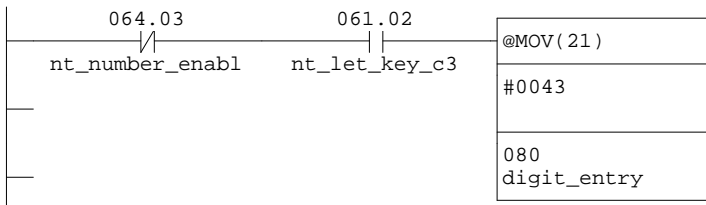
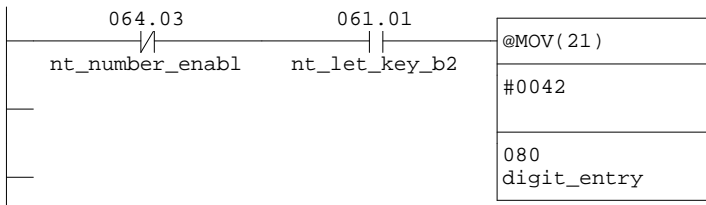
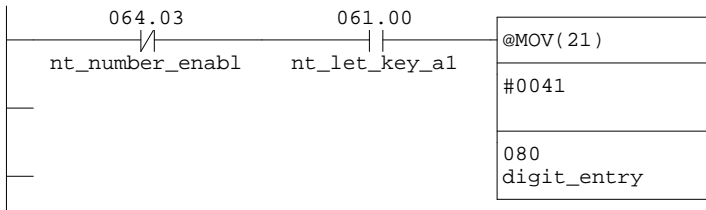

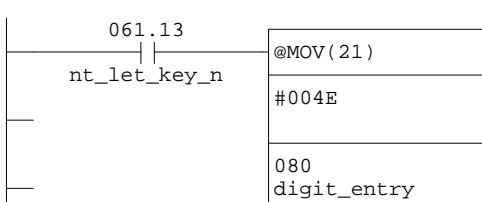
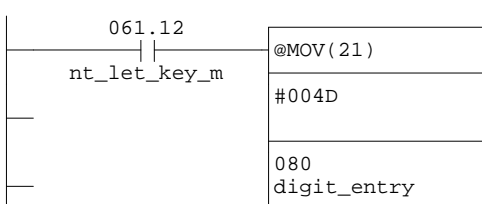
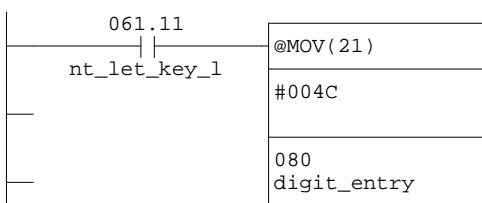
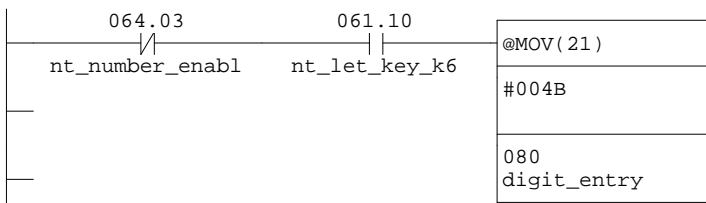
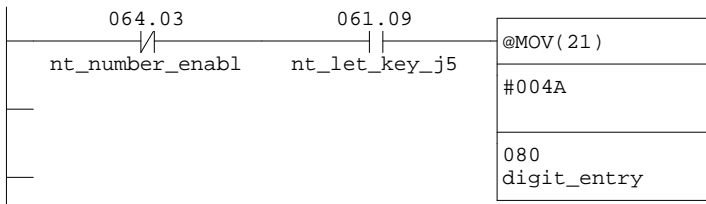
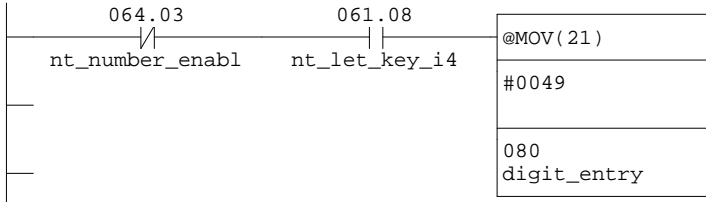
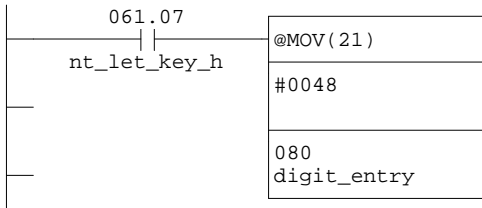

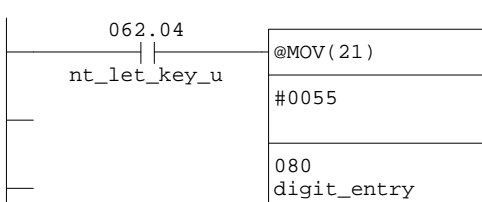
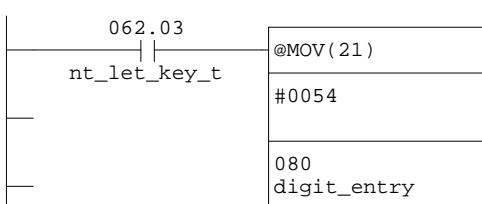
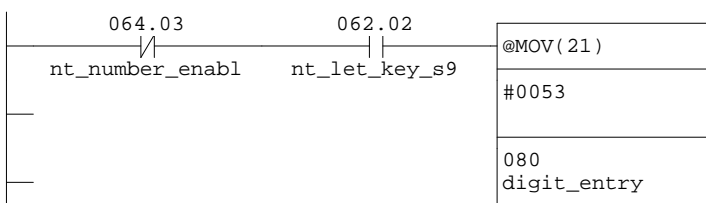
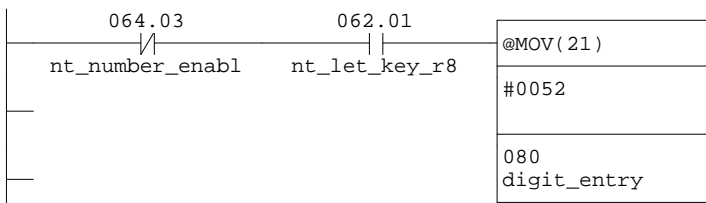
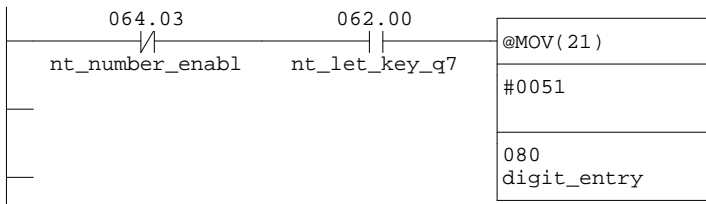
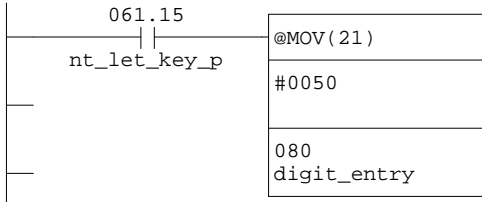
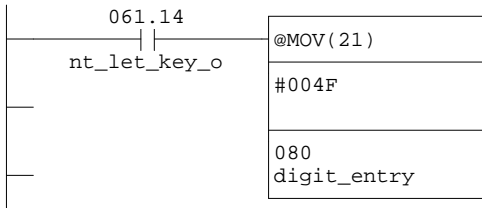



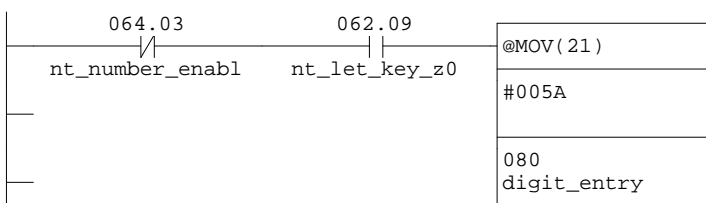
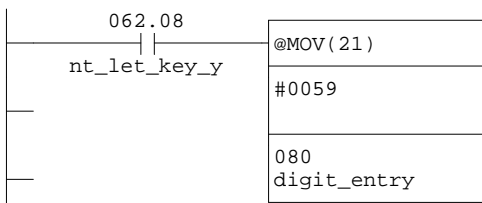
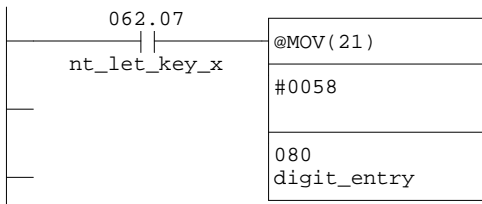
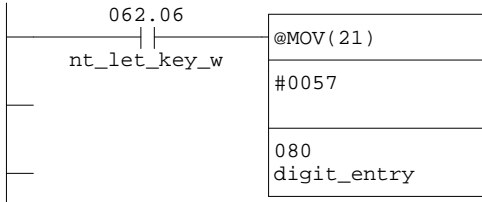
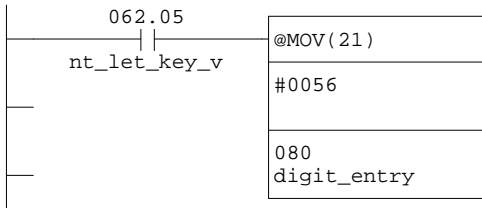

Network 50 - Number entry

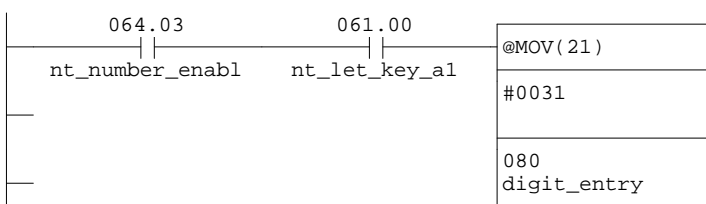
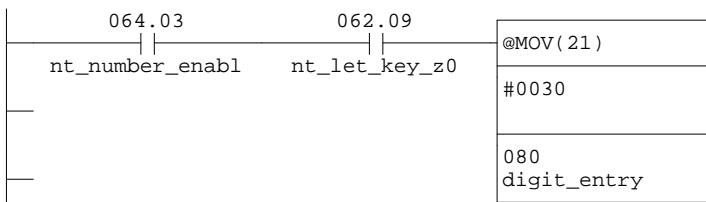

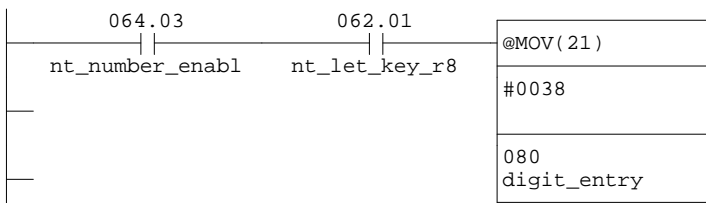
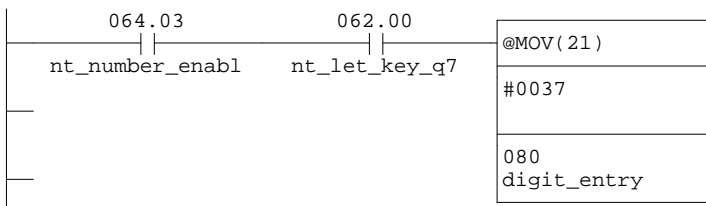
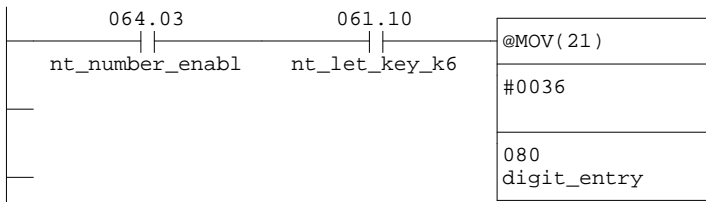
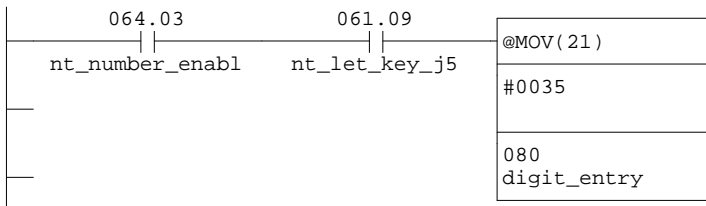
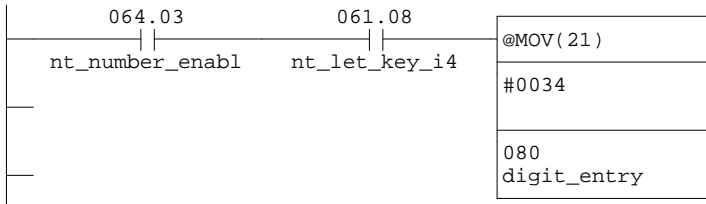
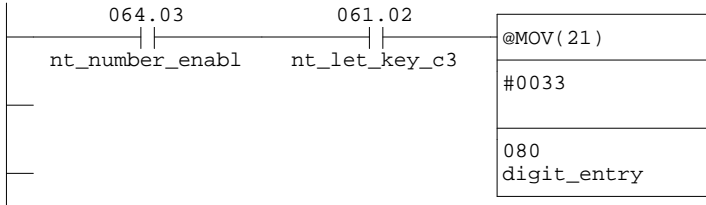
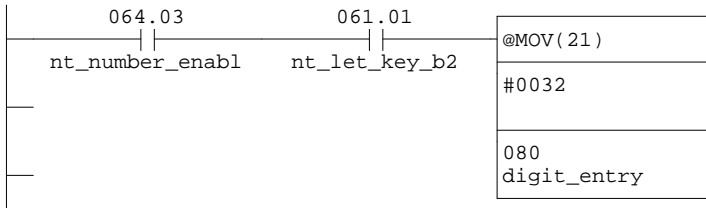

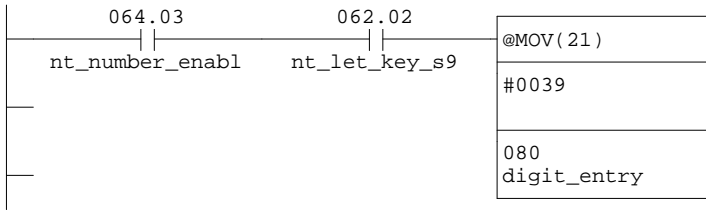

Network 60 - Spacebar

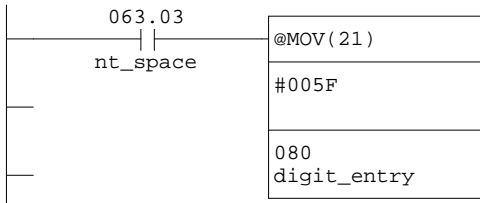

Network 61 - Reset Num Lock

This rung resets the Number Lock when the screen is left.

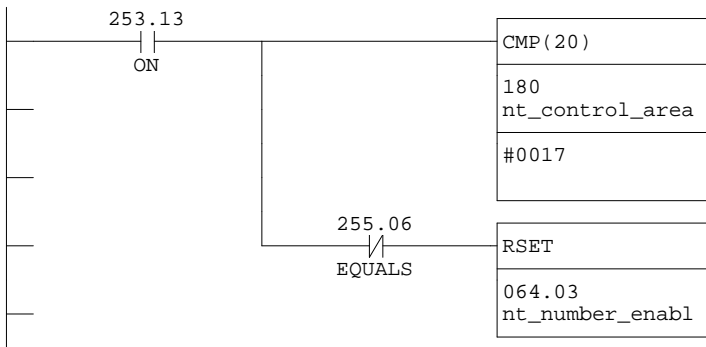

Main 10 - Recipe data

Recipe data handling

Network 1 - Set scaling



Network 2 - Set pointer

Set recipe 1st word pointers

NOTE:- Pointer value changed on ADD command from #0100 to #0080

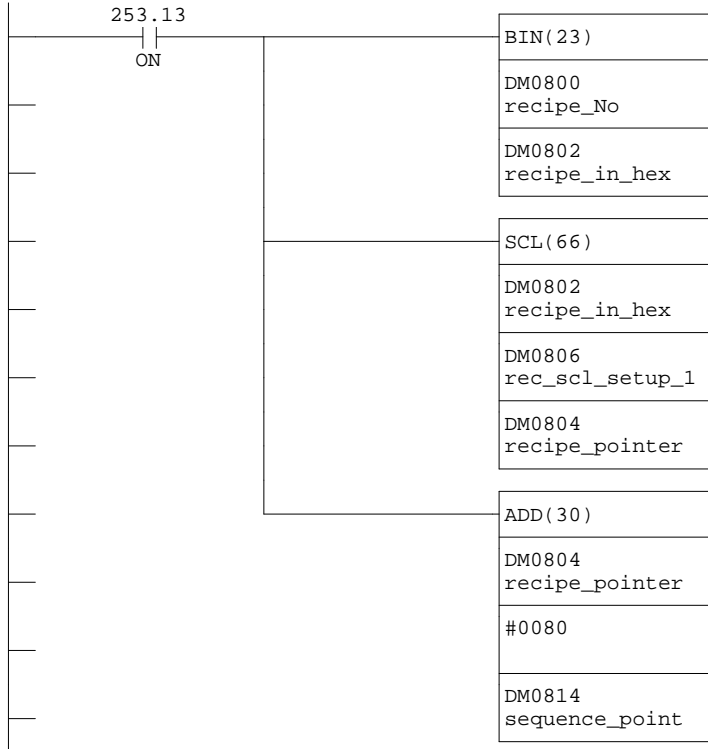

Network 3 - Recipe change

Detect recipe change then upload data from the store.

NOTE:- Changed XFER from #0100 to #0080 to stop corruption of DM areas

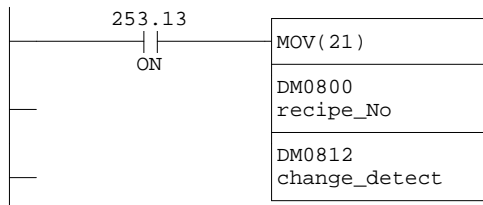
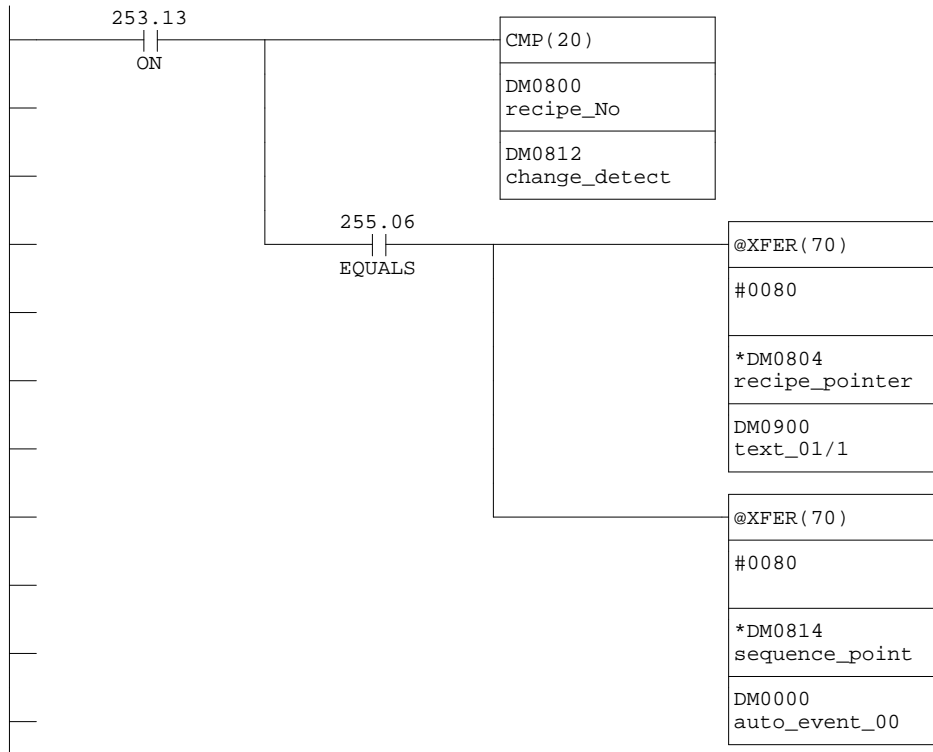

Network 5 - Select text

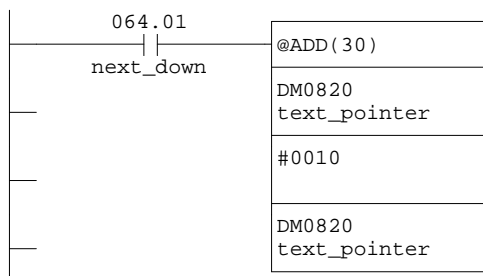

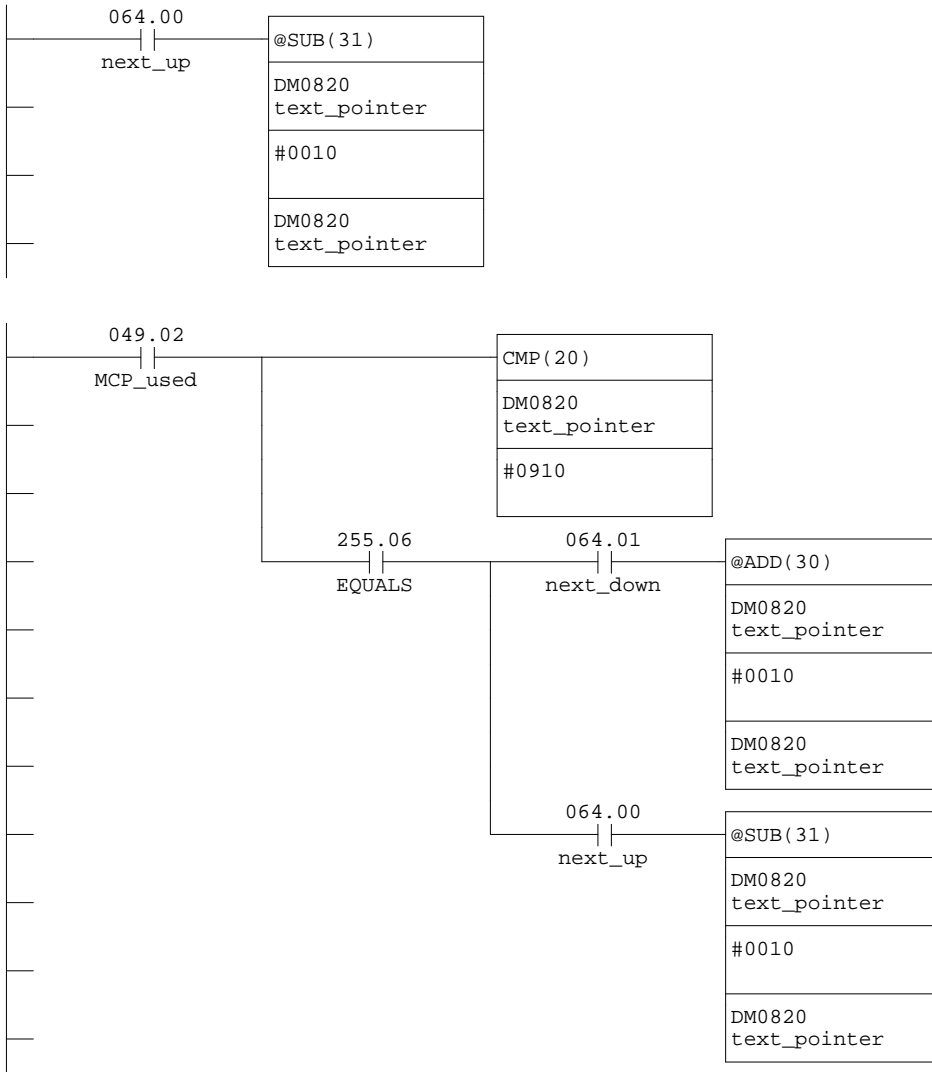

Network 8 - Text limits

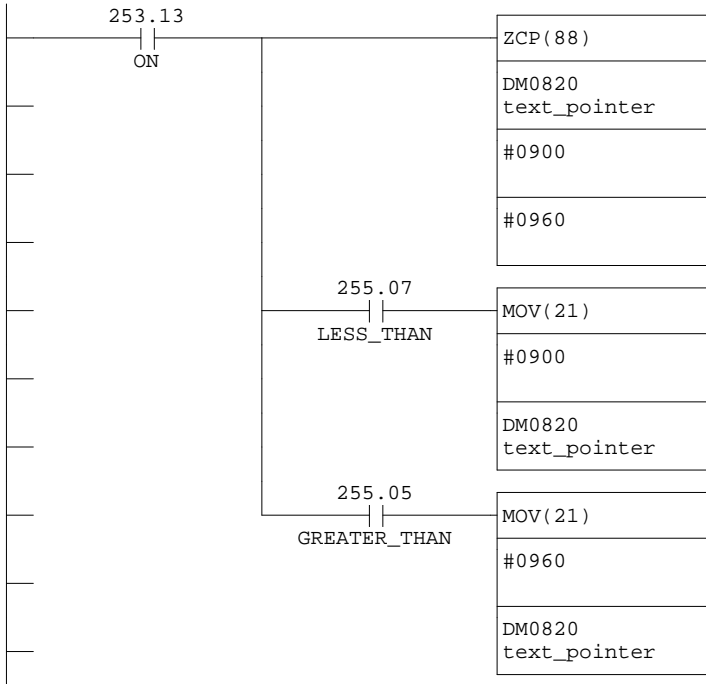

Network 9 - Text help

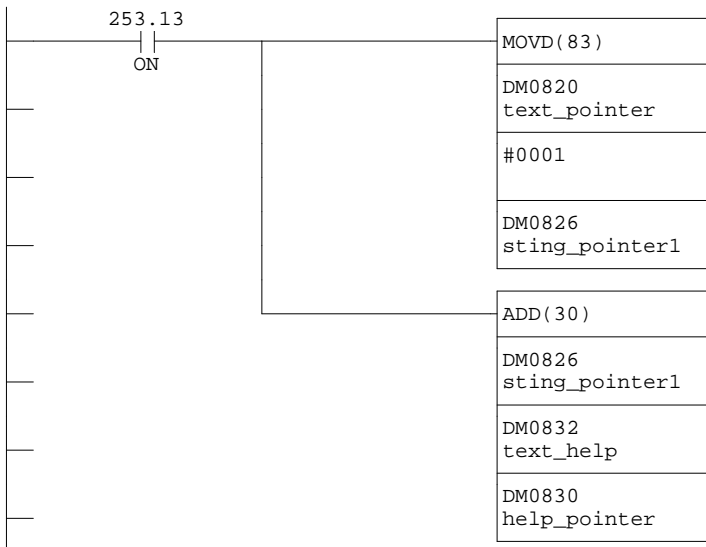



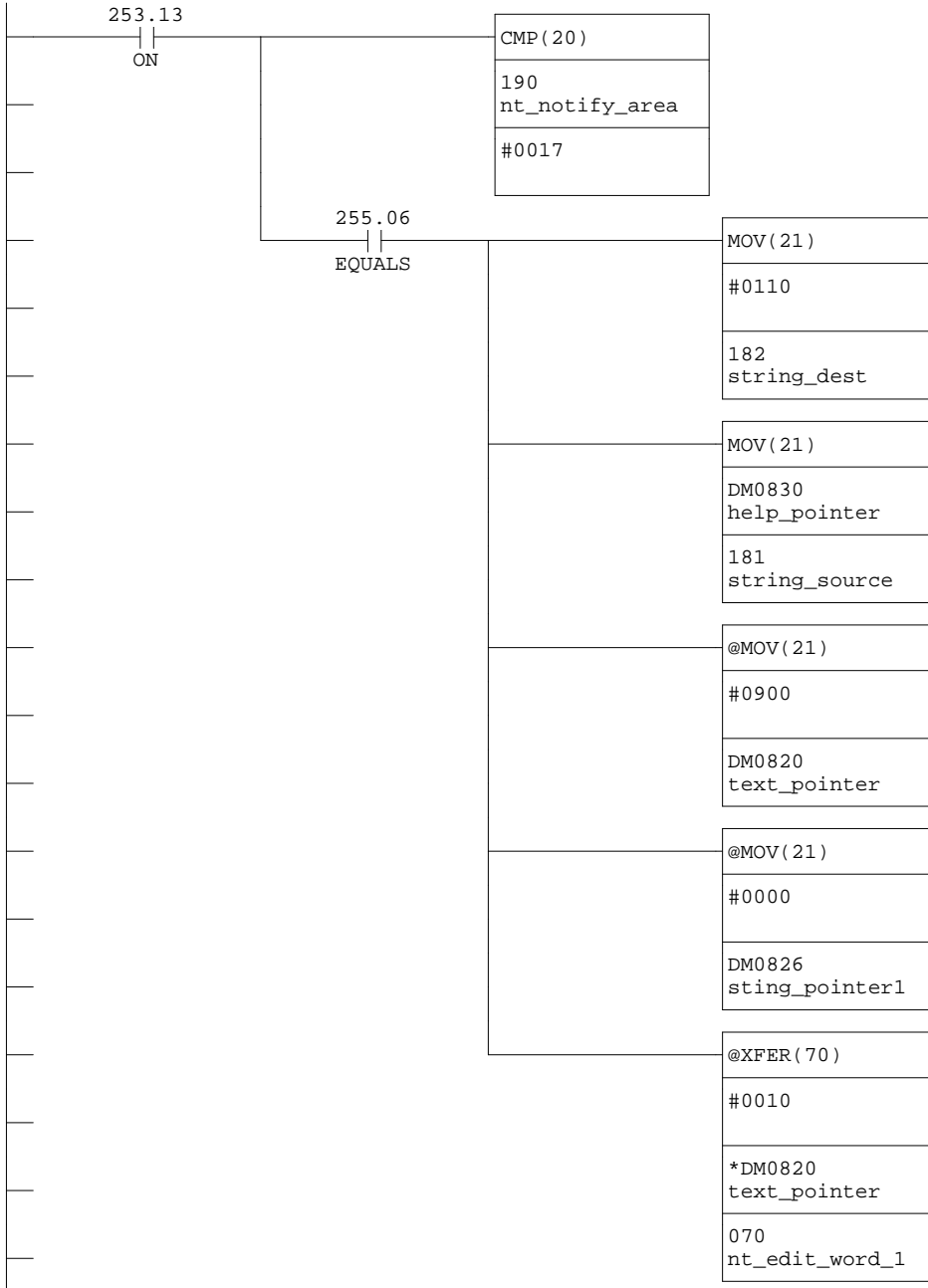

Network 11 - Text change

Detect text change then upload data from the active area.

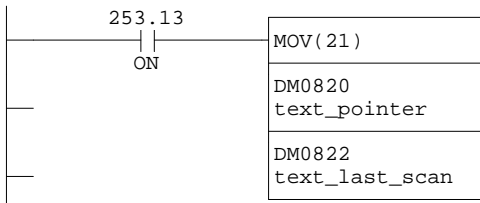
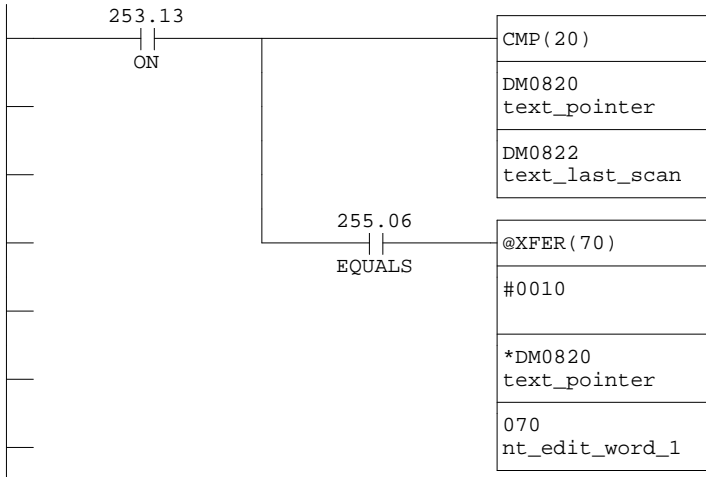

Network 13 - Save recipe

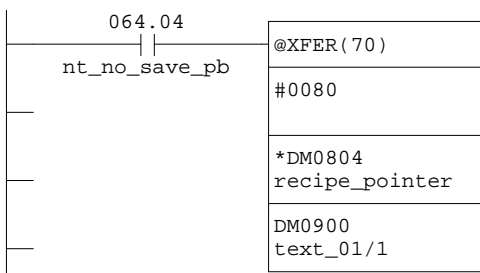
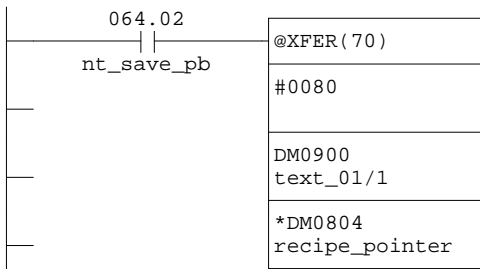

Main 11 - Easy edit

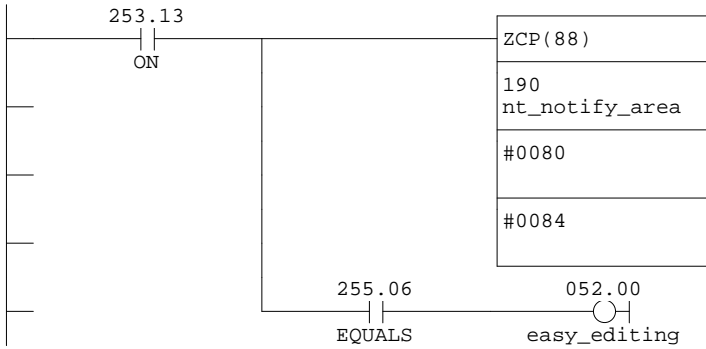

Network 2 - Unused DM's

Set all unused data memories in the active editing area to #0000

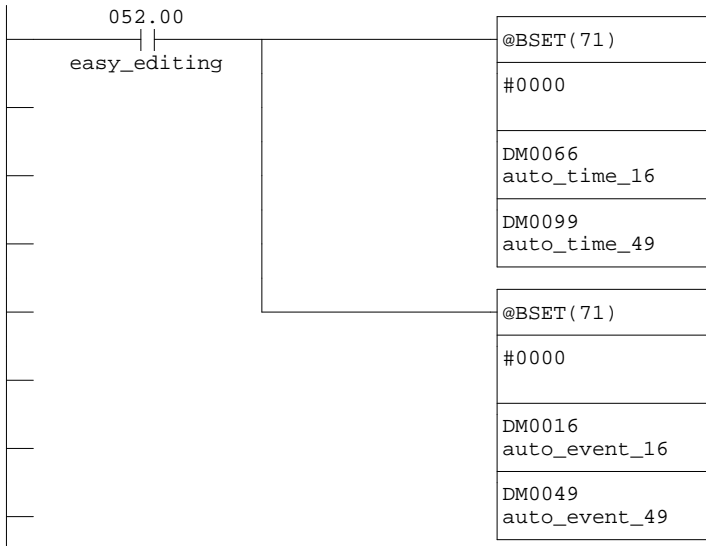

Network 3 - Mix 1 convert

Convert mix times to seconds

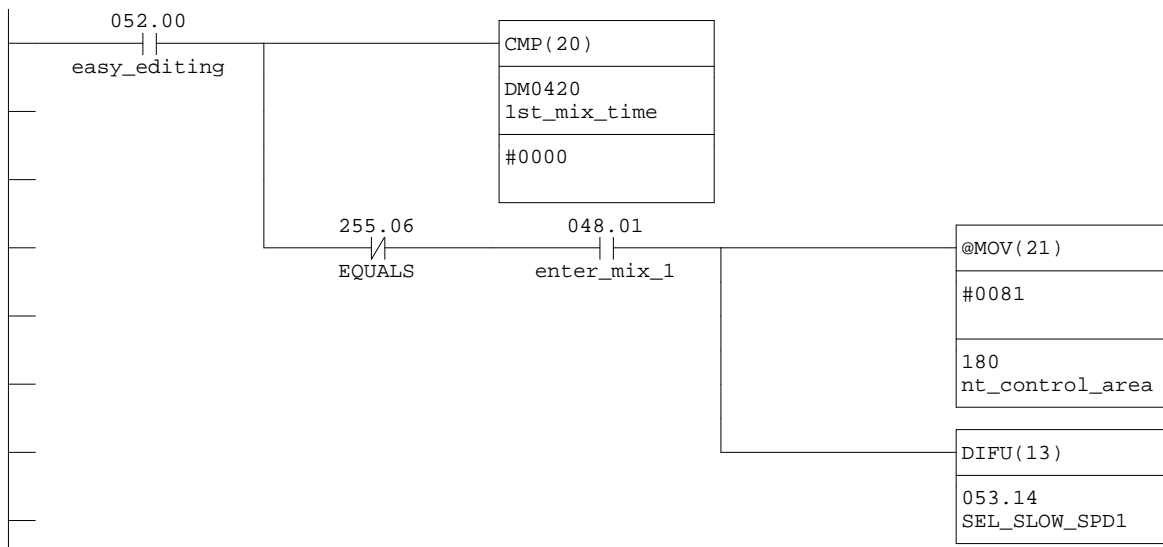
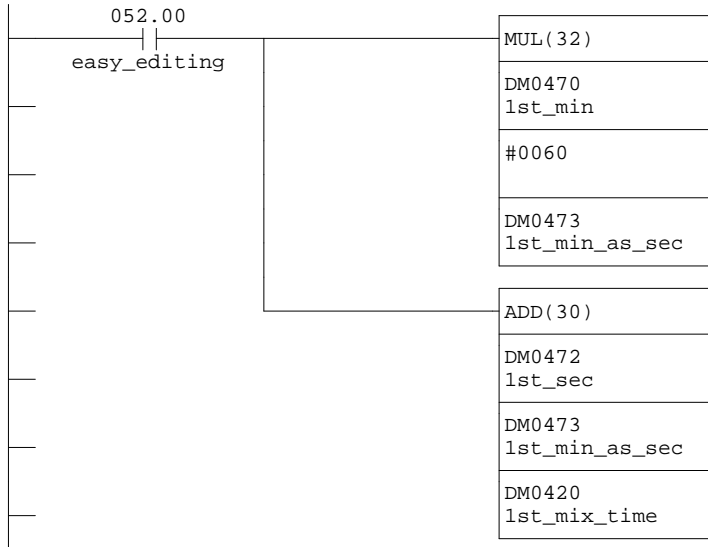

Network 5 - Speed 1

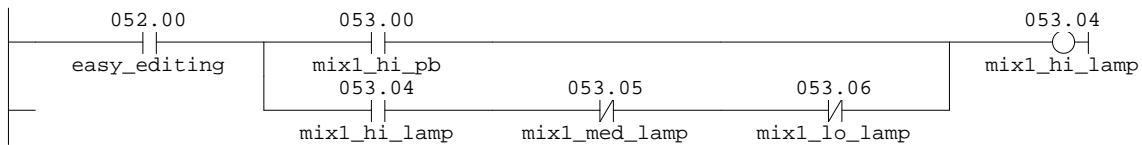

Network 6 - Speed 1

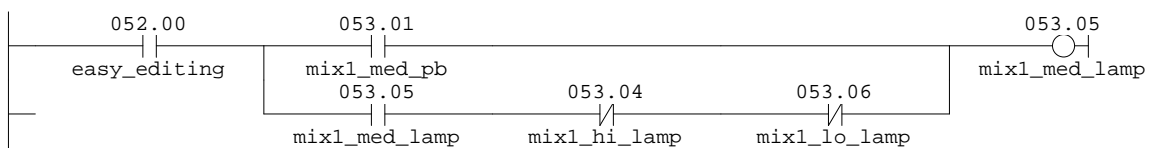

Network 7 - Speed 1

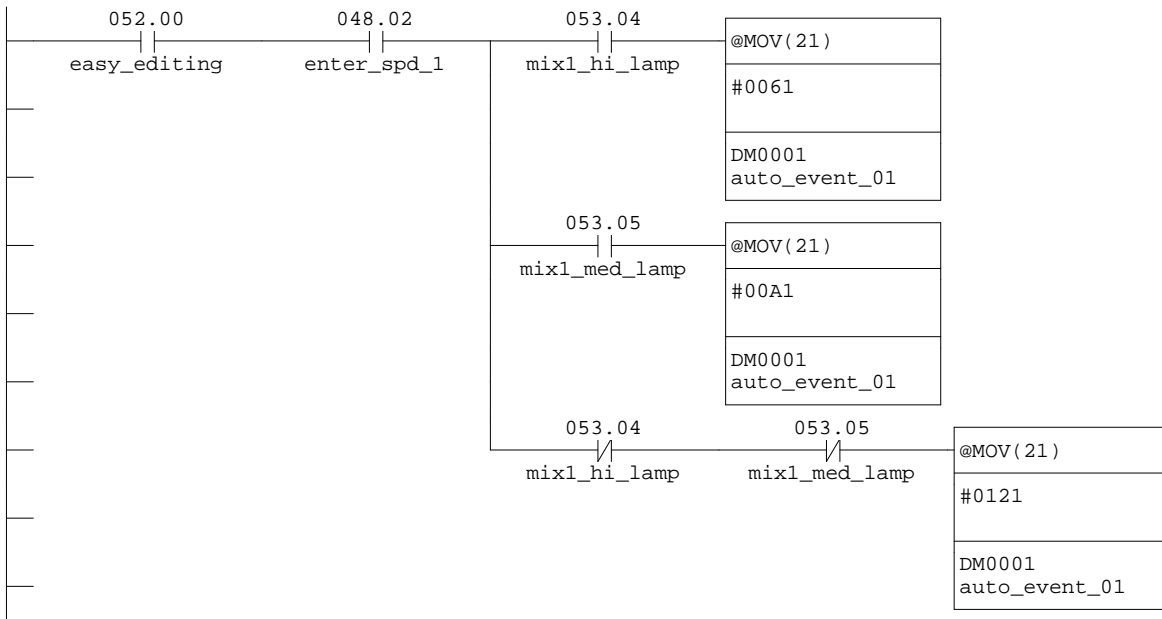
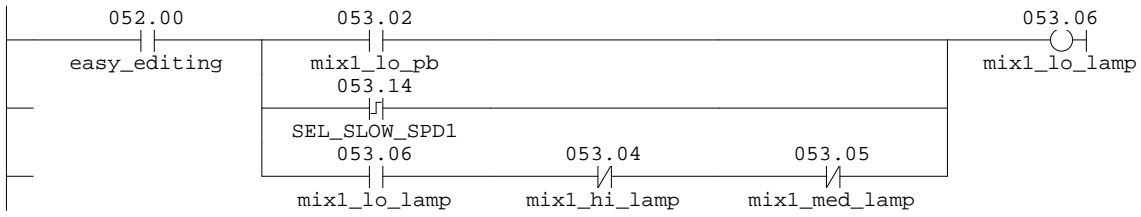

Network 9 - 3 steps

Make the first three steps the same in case the program needs editing at a later date.

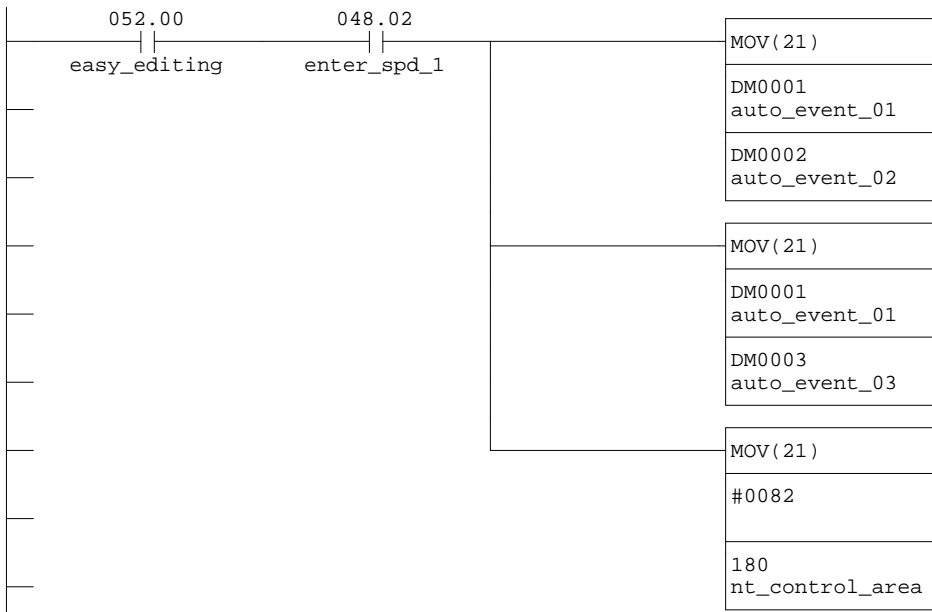

Network 10 - Mix 2 convert

Convert mix times to seconds

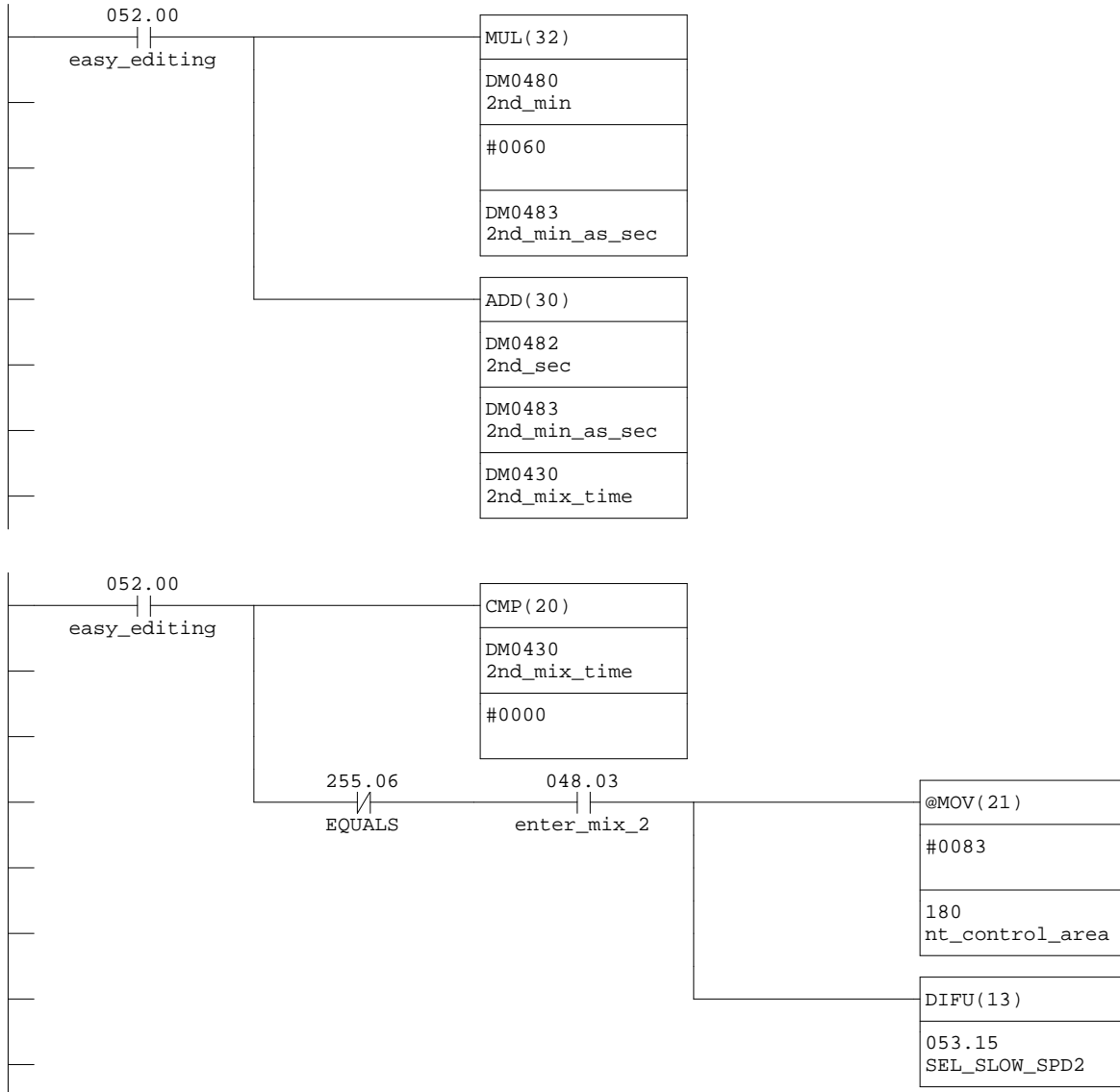

Network 12 - Speed 2

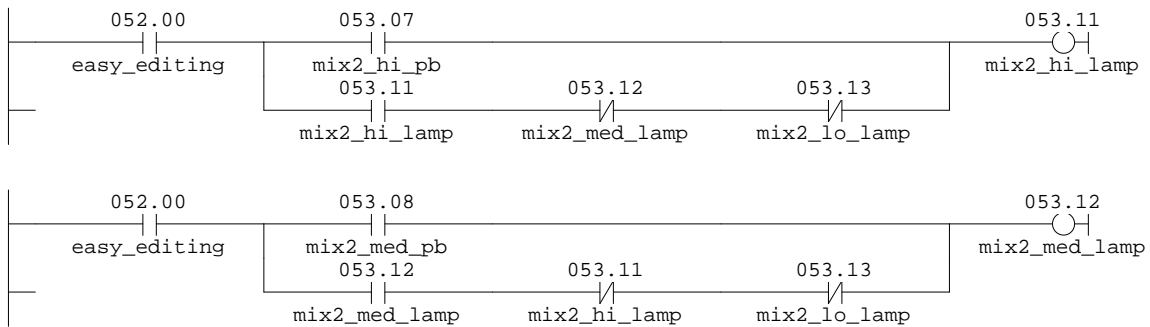

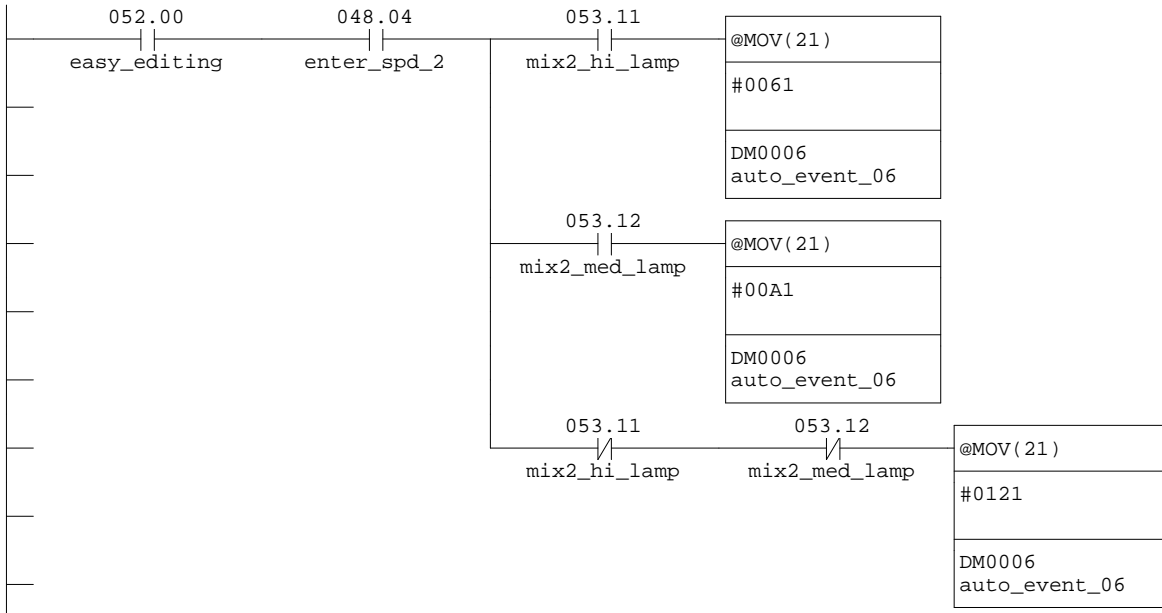
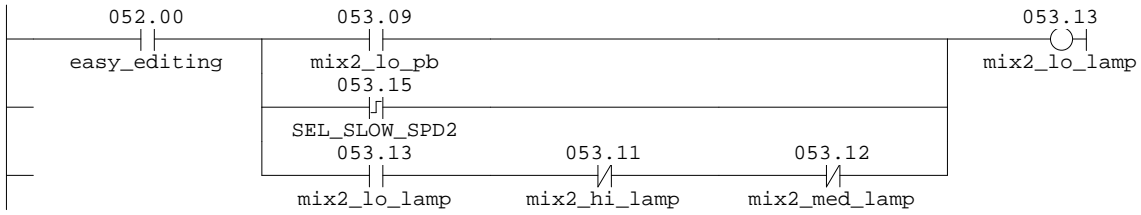

Network 16 - 3 steps

Make the next three steps the same in case the program needs editing at a later date.

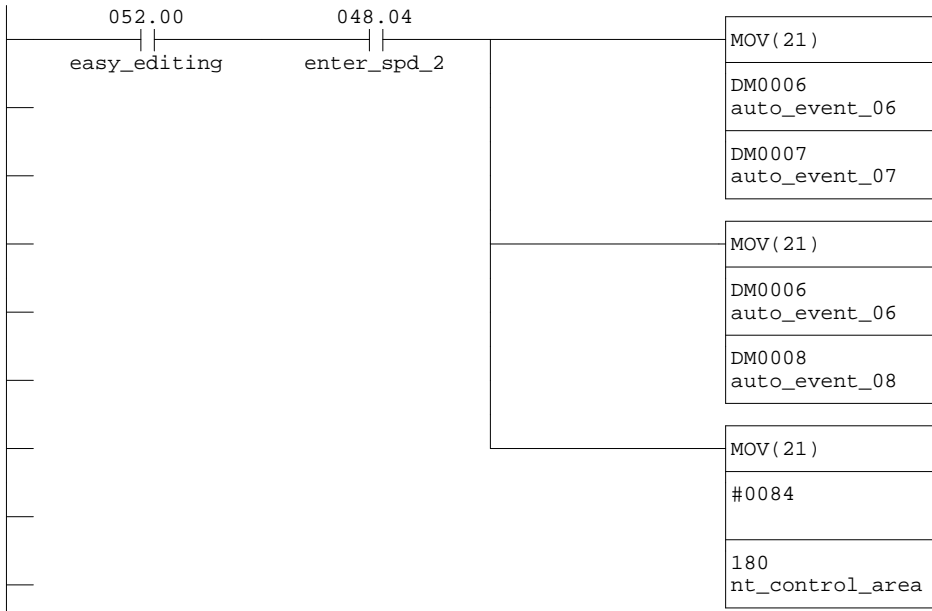

Network 17 - Leak convert

Convert Leak time to seconds

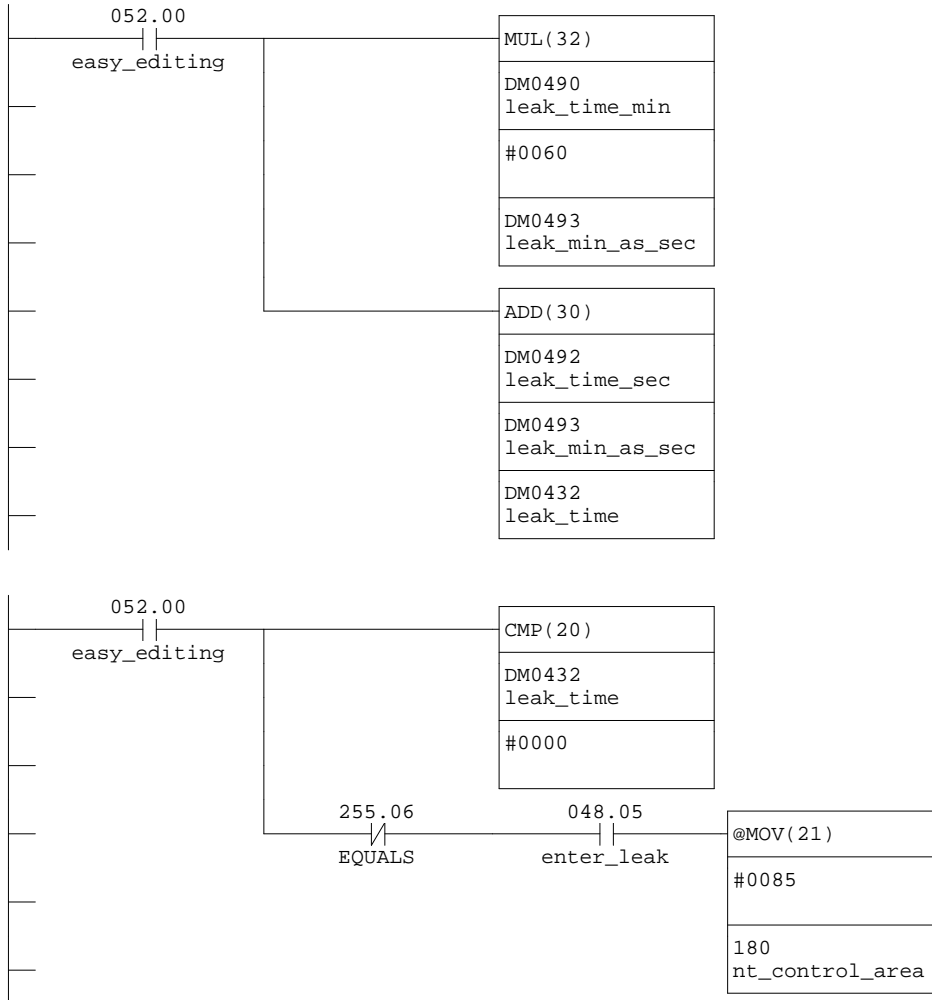



Network 19 - Default mix tim

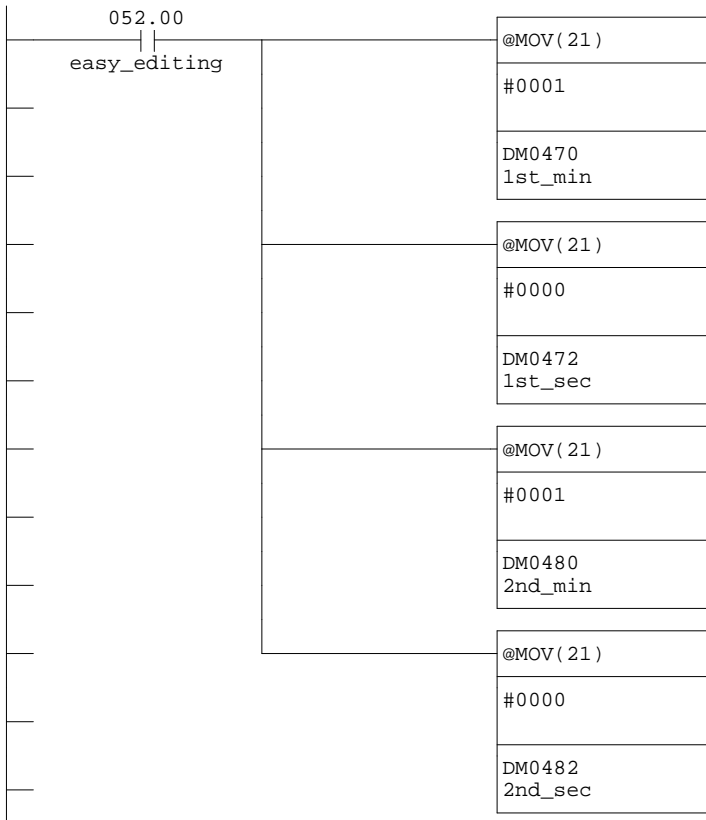

Network 20 - Set tim 0-3

Set the first four time intervals

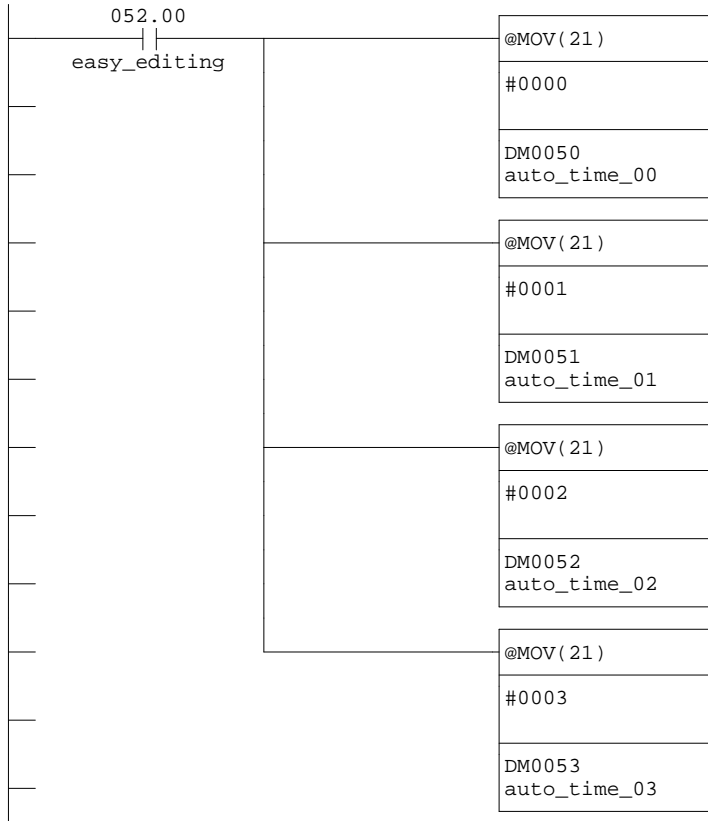

Network 21 - Set tim 4-6

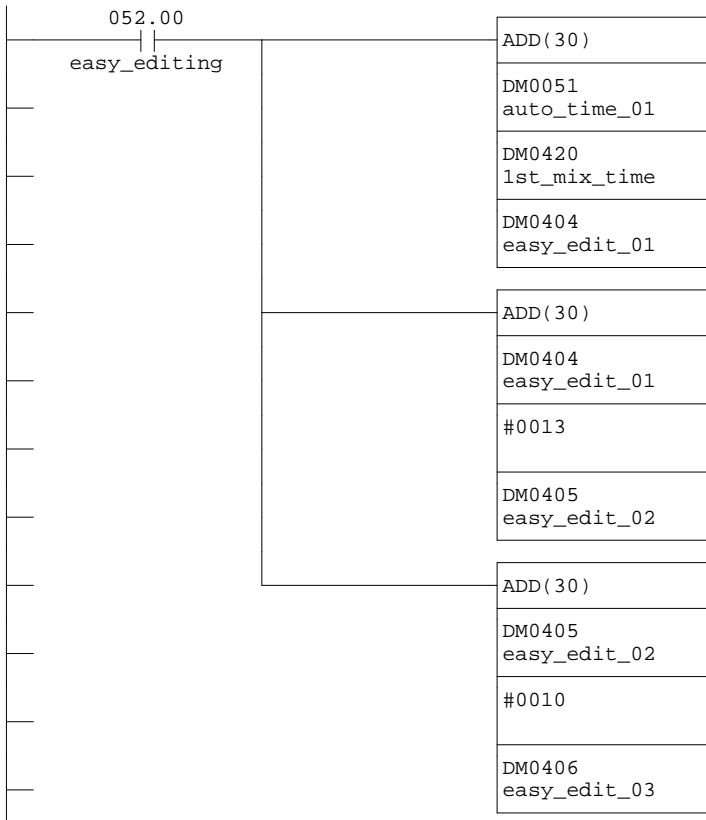

Network 22 - Set tim 7-9

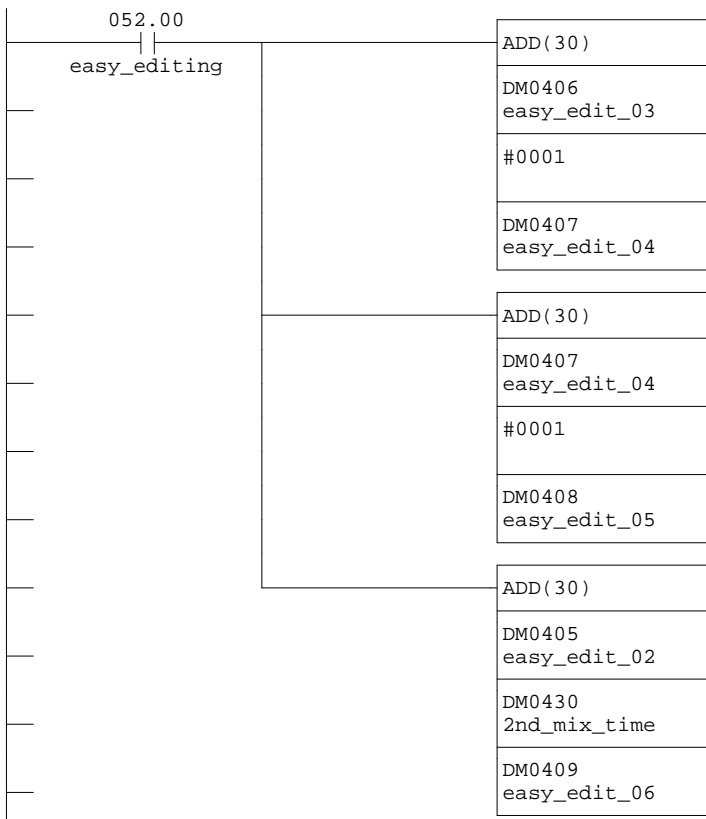

Network 23 - Set tim 10-12

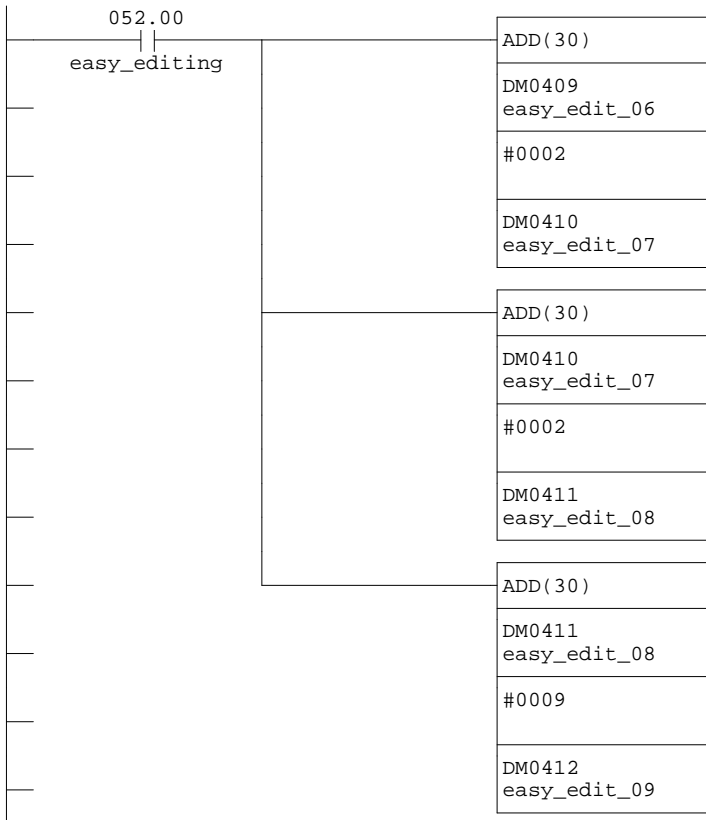

Network 24 - Set tim 13-15

The last ADD(30) instruction in this network adds the fixed "LEAK TIME DM434" to the easy edit program. This is set at 25sec for the 001, 60 seconds for the 004 and 120 seconds for the 005.



Network 25 - Convert

Convert all results to minutes + seconds

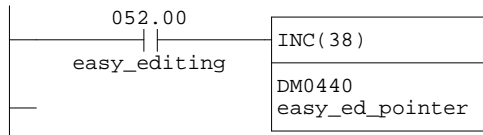

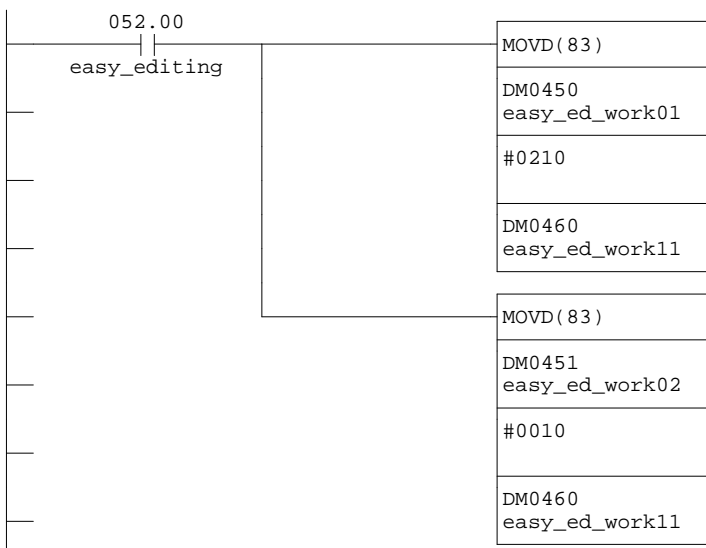
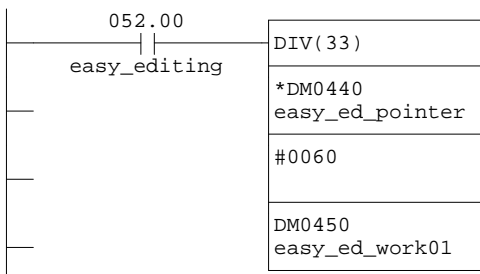
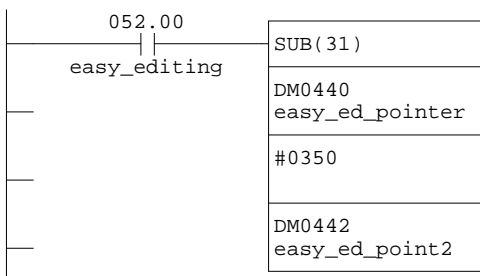
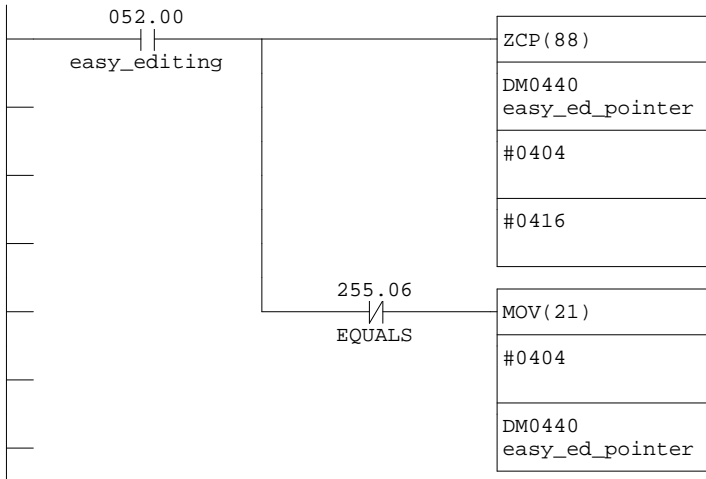

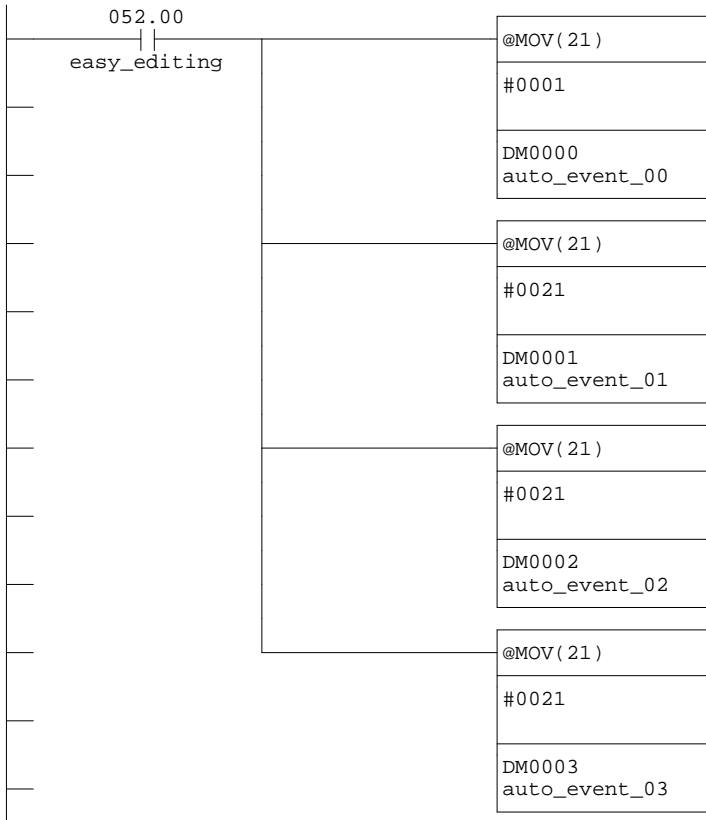
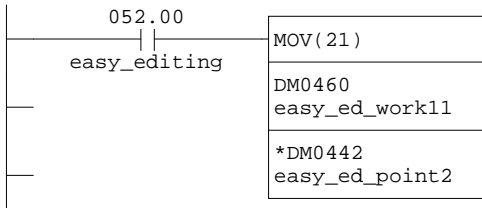

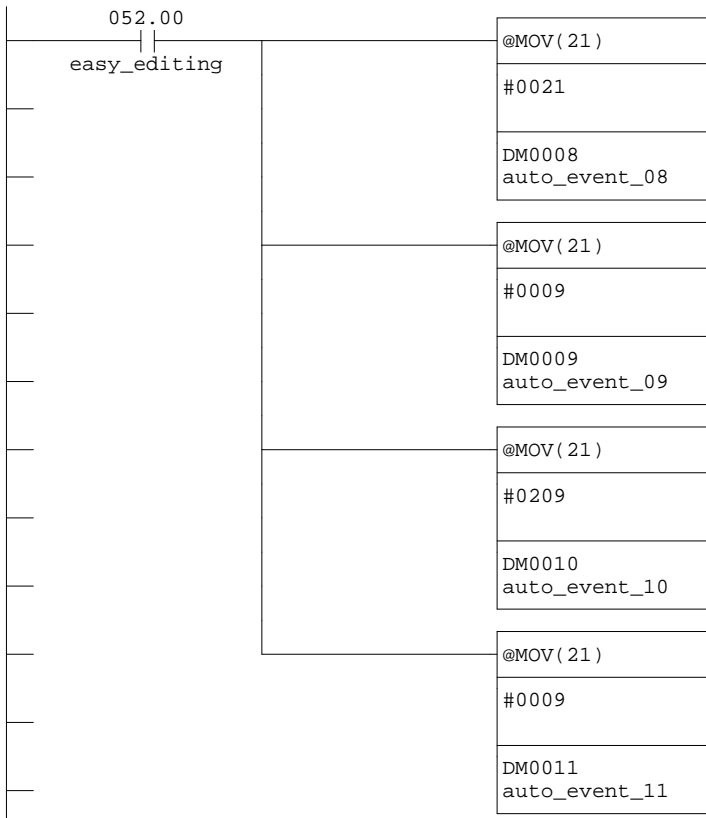
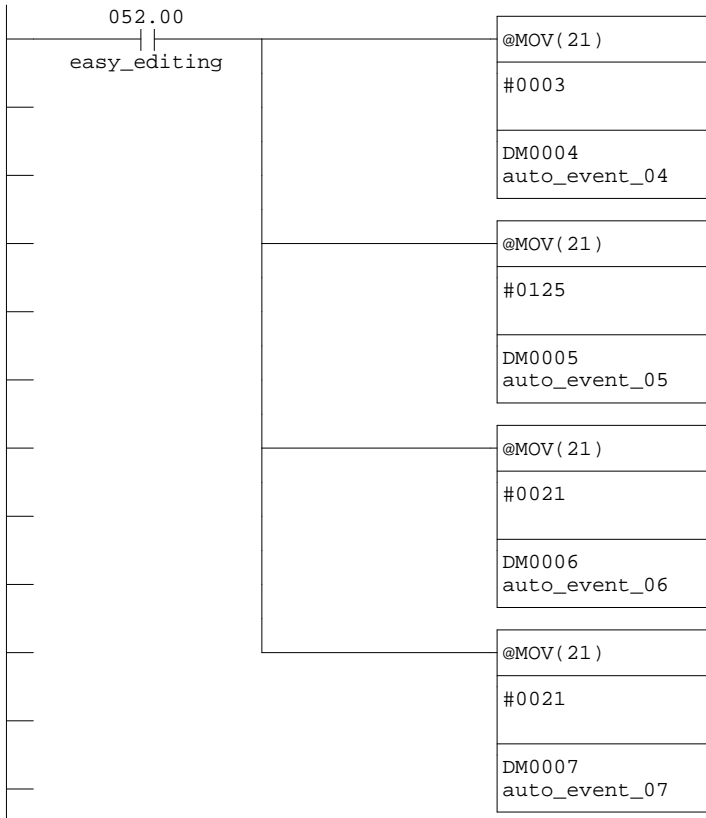



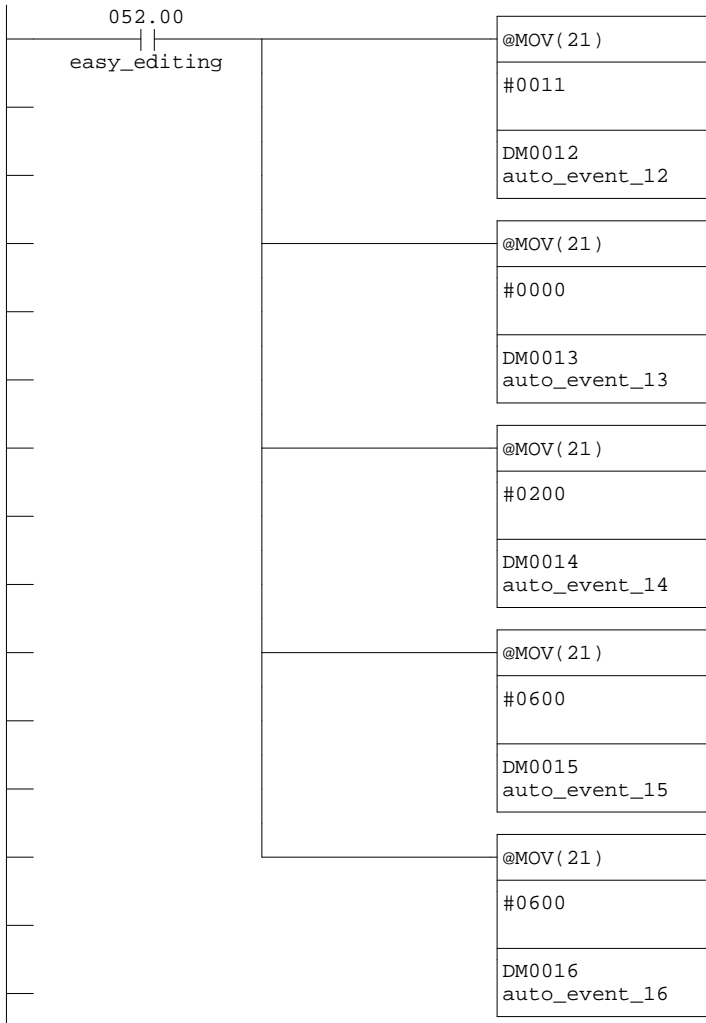

Network 35 - Save easy prog

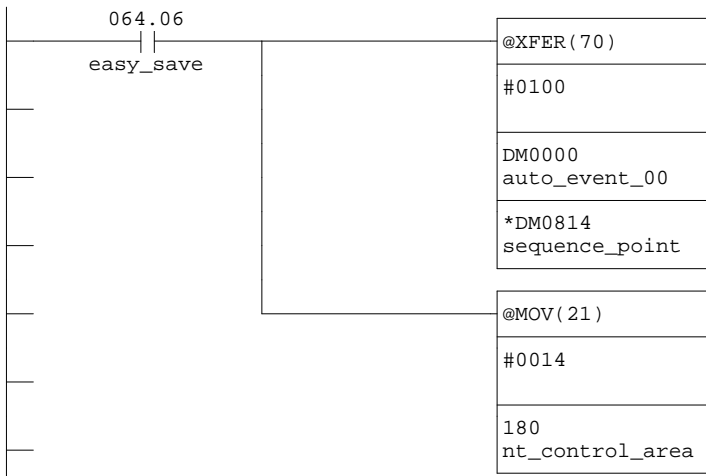

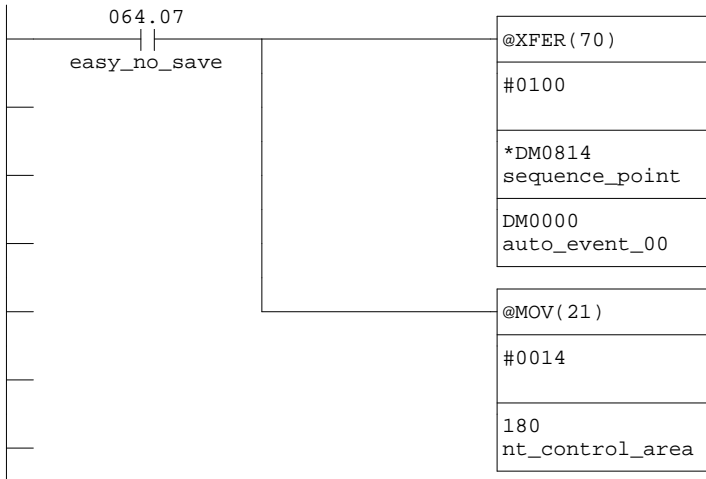

Main 12 - Advanced edit

Network 1 - Move to edit

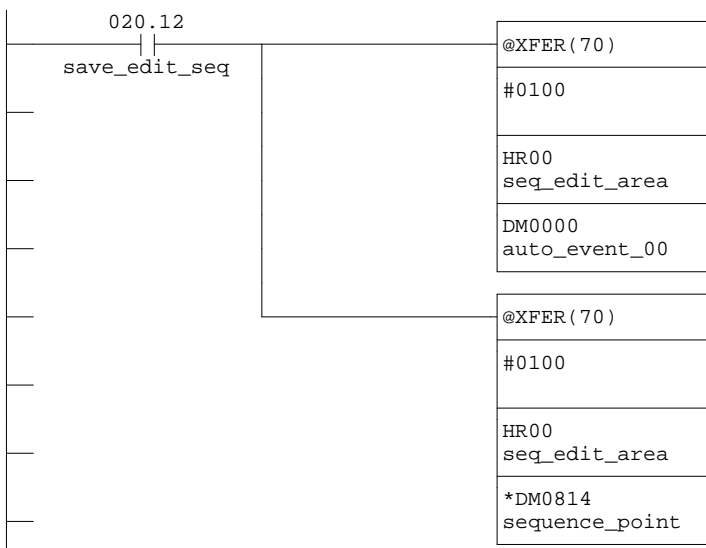
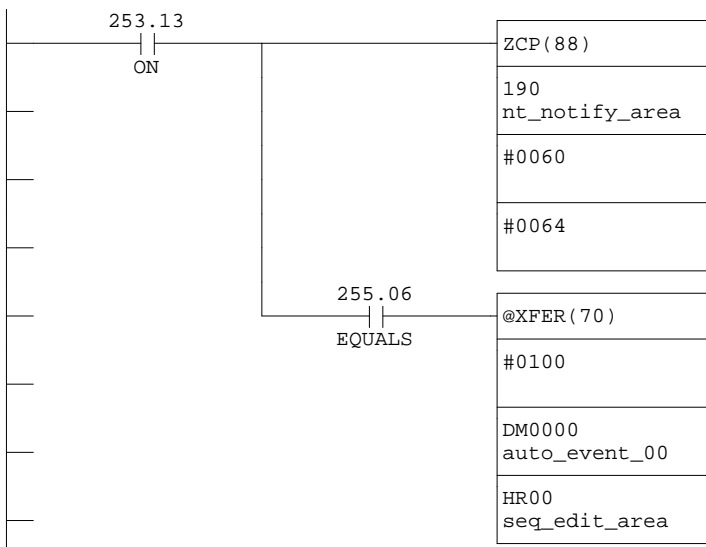

Main 13 - E/stop

Network 1 - E/Stop

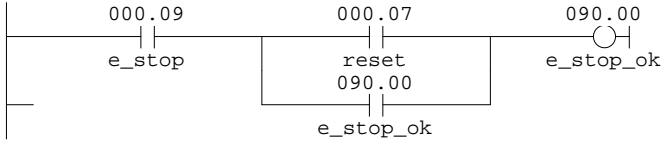

Network 2 - Door switch

Network inhibited (25314) on the heated cup/oven machines, as the system off bit also disables the temperature control output.  
 The Door switch in the open position will turn the output inhibit bit on. This prevents any output from the PLC

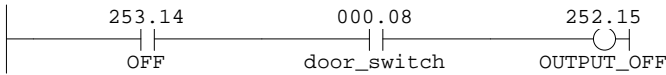

Main 14 - Manual control

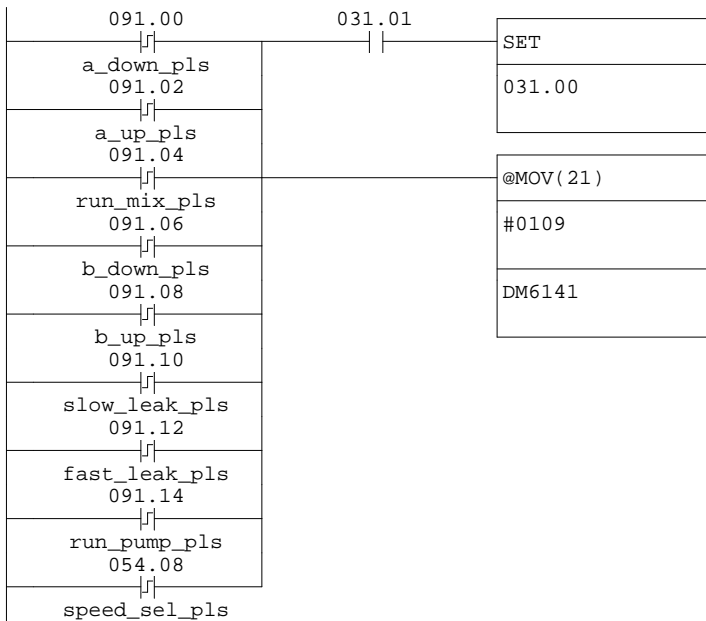
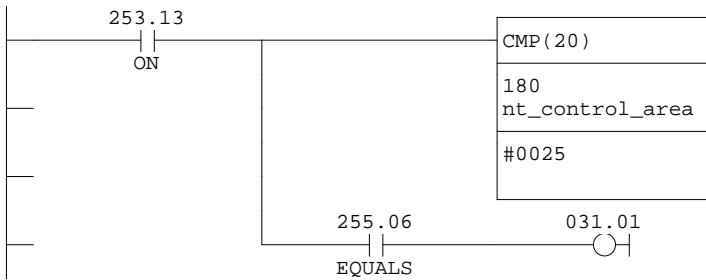

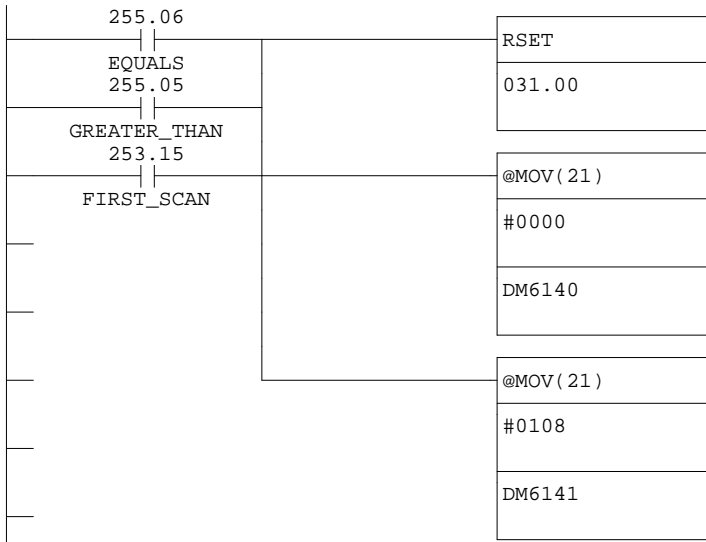
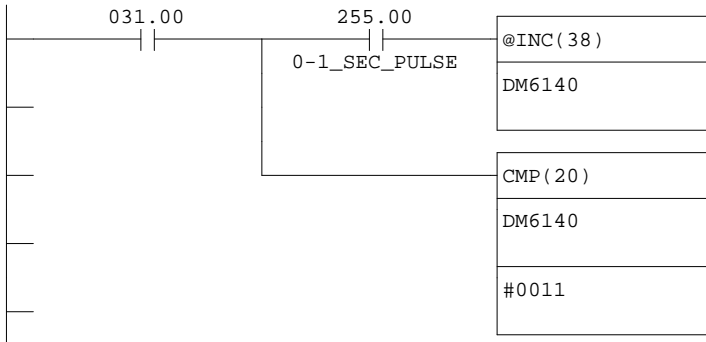

Network 5 - Lower "A"

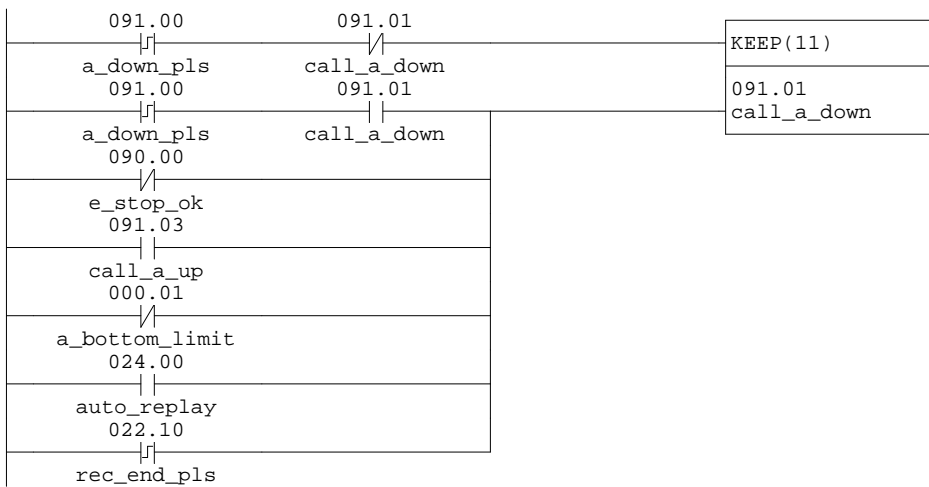
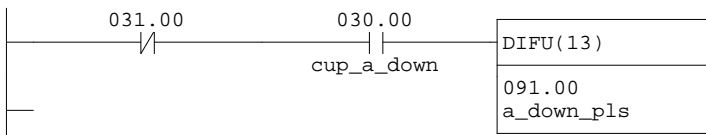

Network 7 - Raise "A"

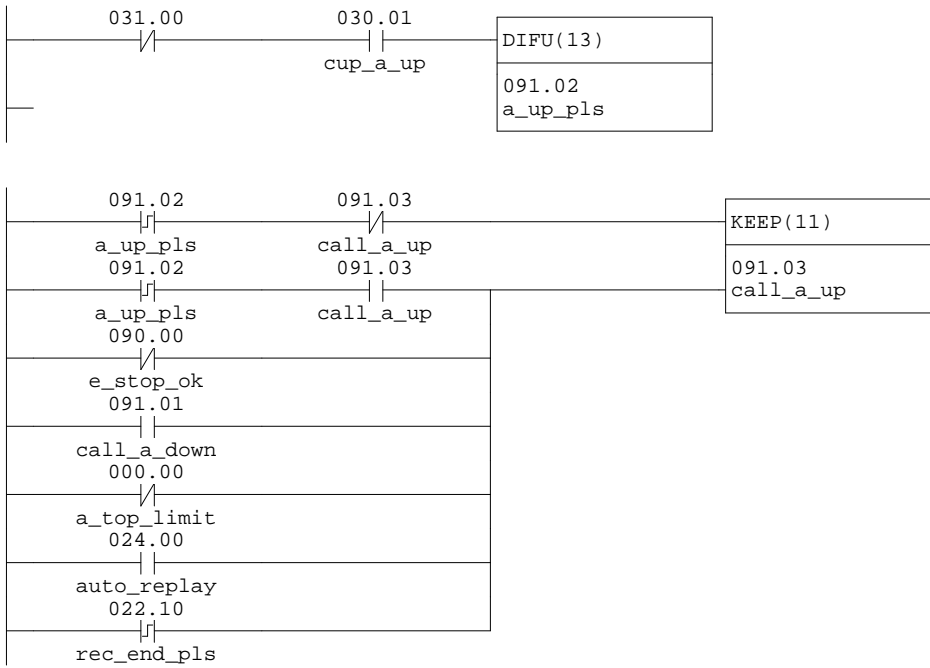

Network 9 - Run mixer

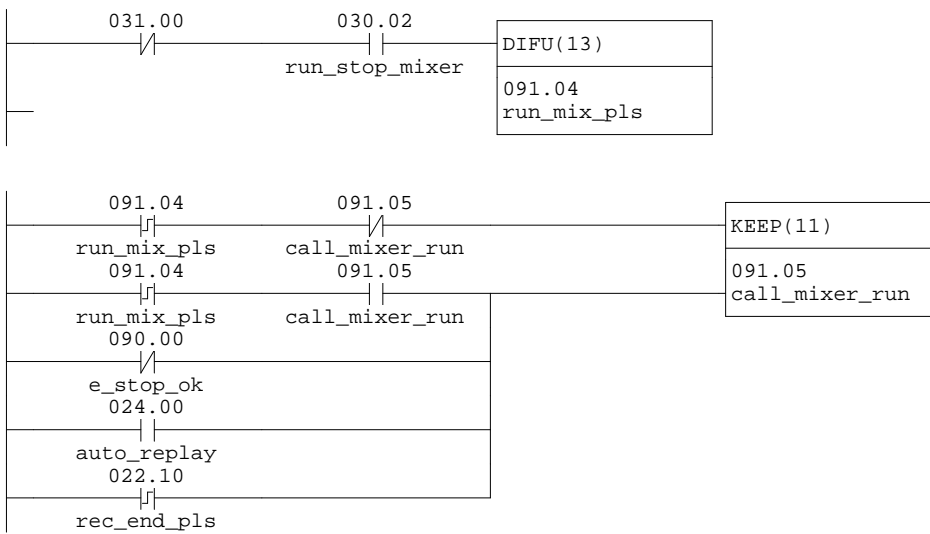

Network 11 - Lower "B"

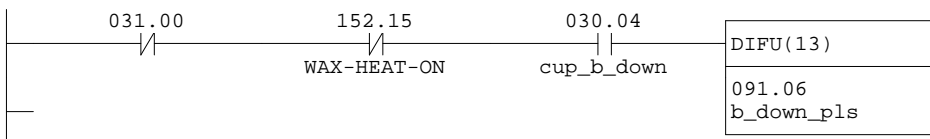

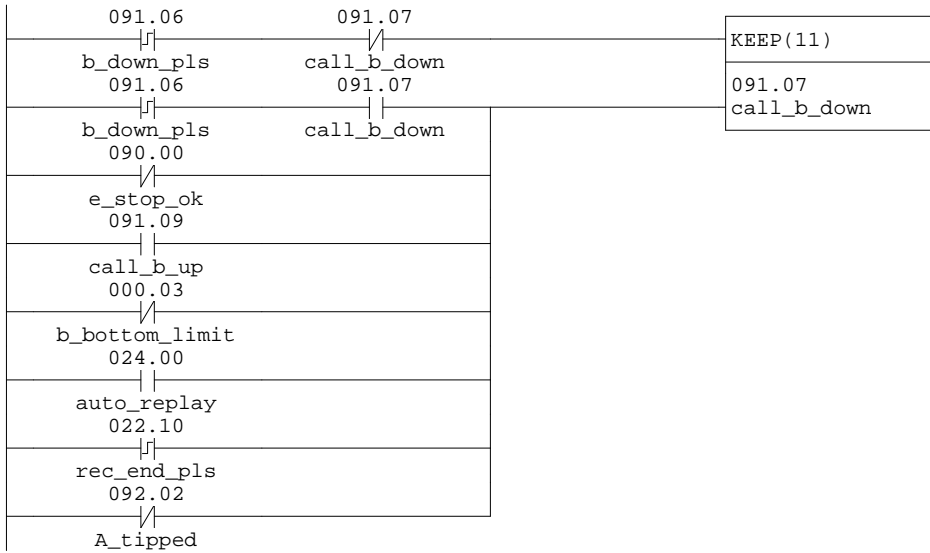

Network 13 - Raise "B"

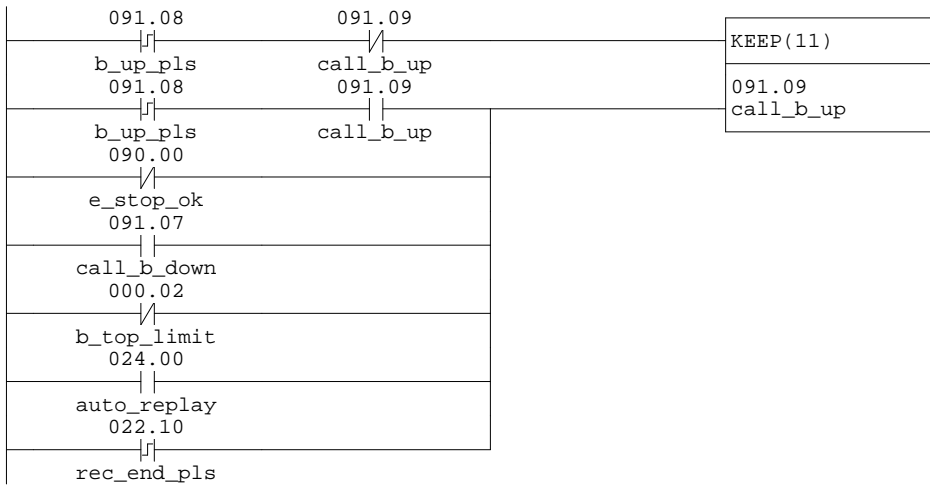
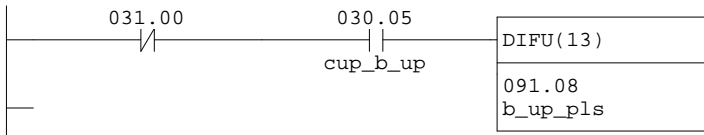

Network 15 - Slow leak

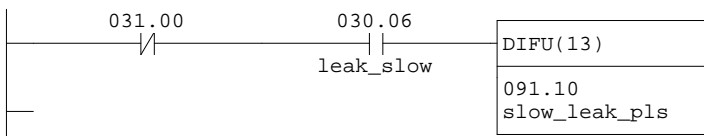

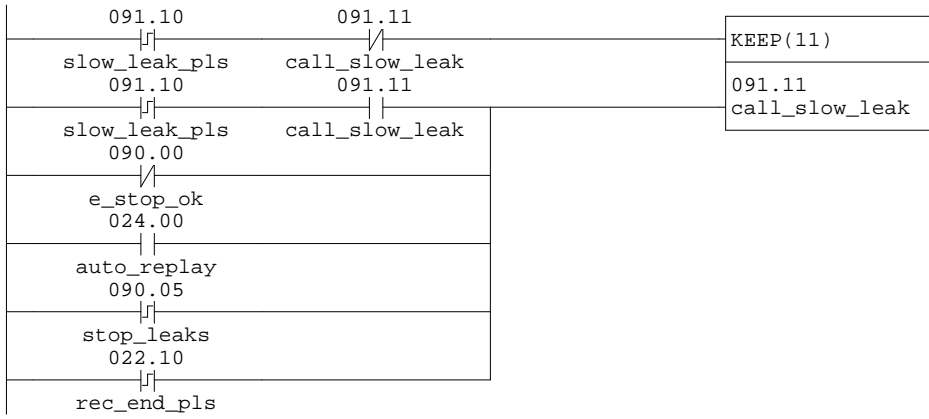

Network 17 - Fast leak

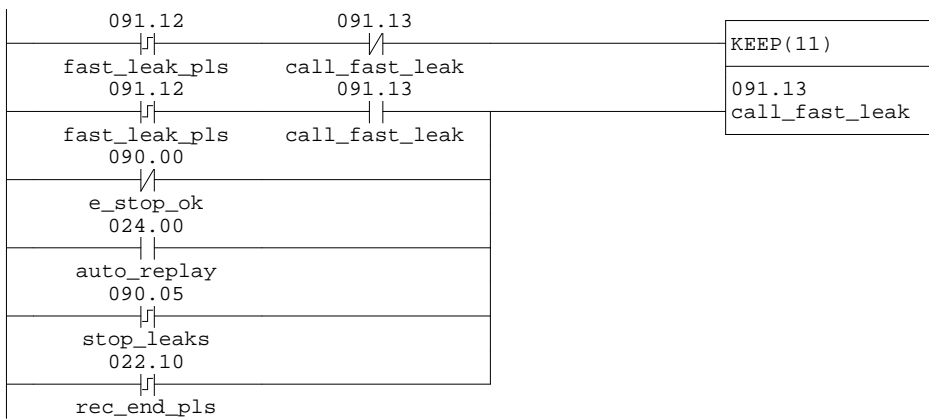
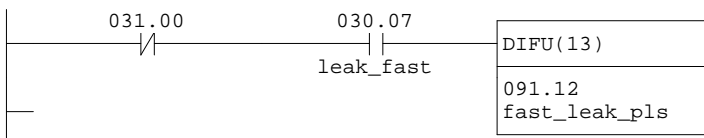

Network 19 - Run Pump

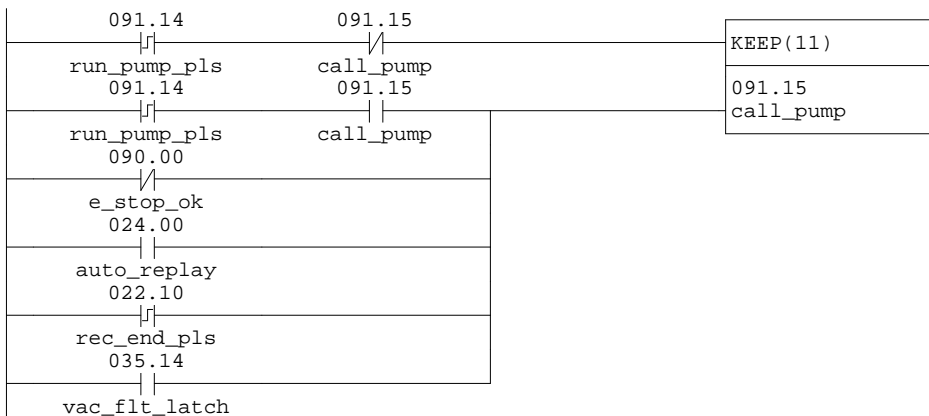
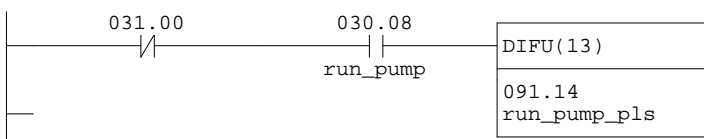

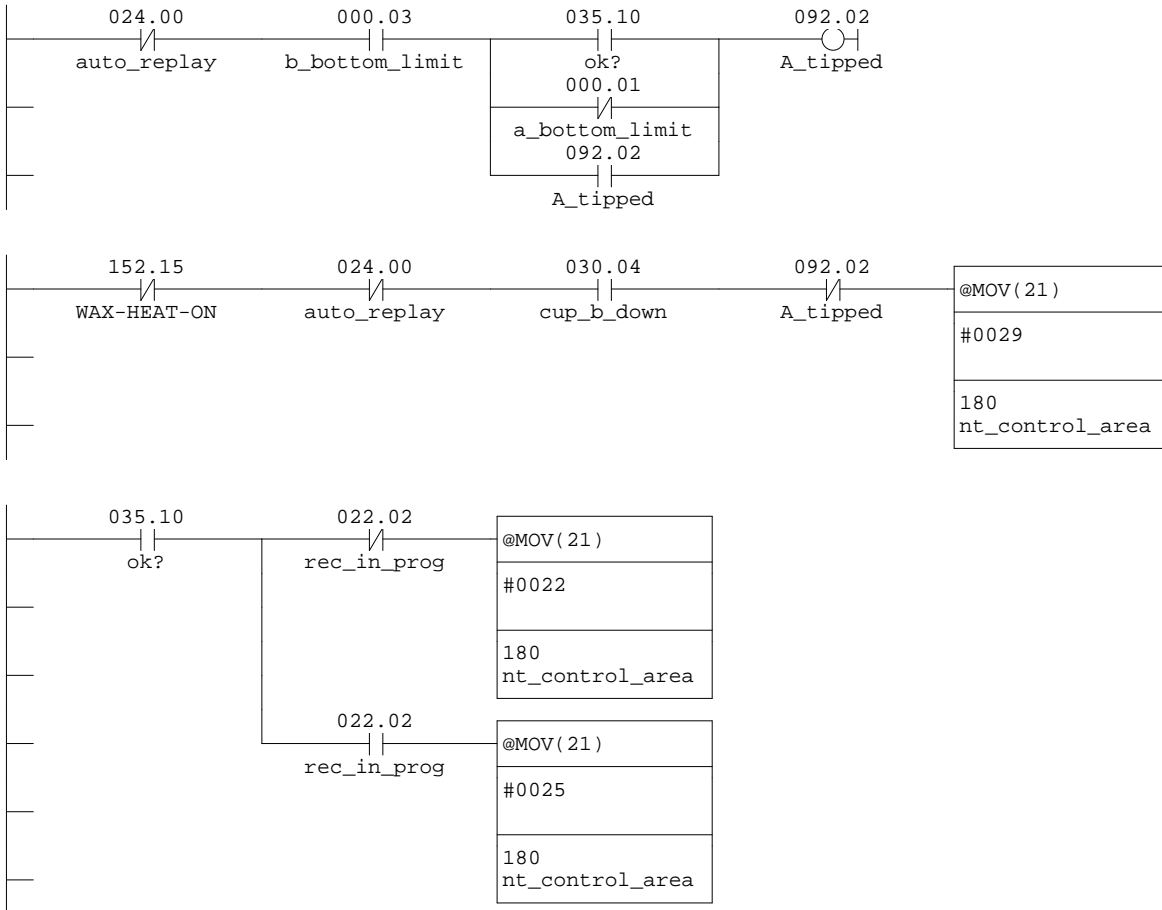

Main 15 - Speed select

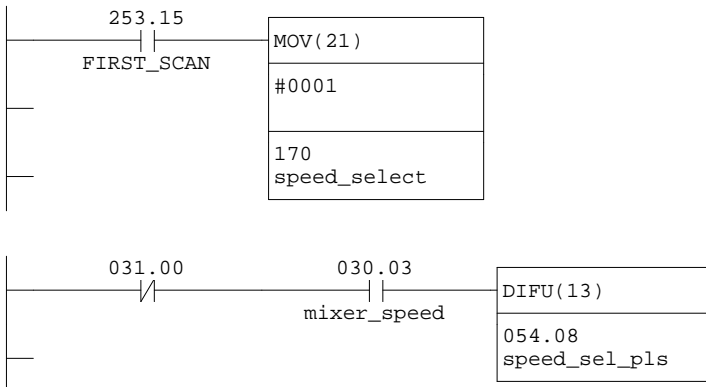



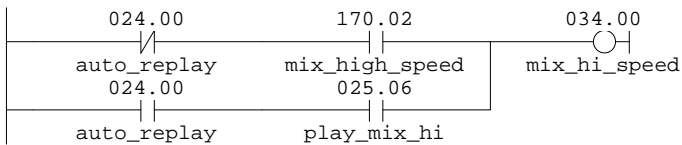
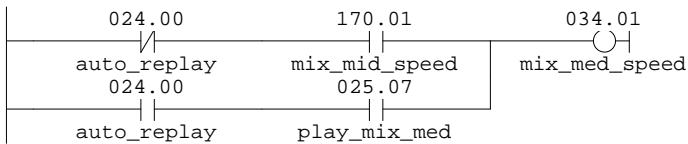
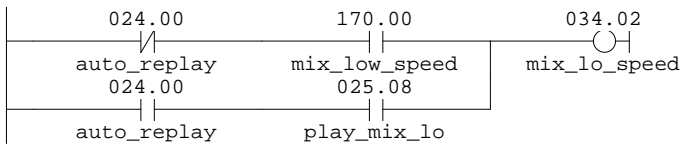
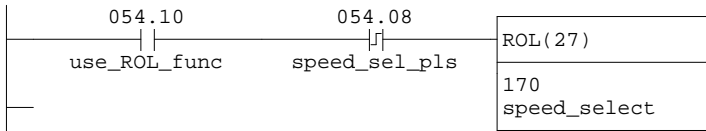
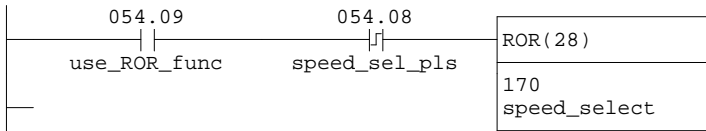
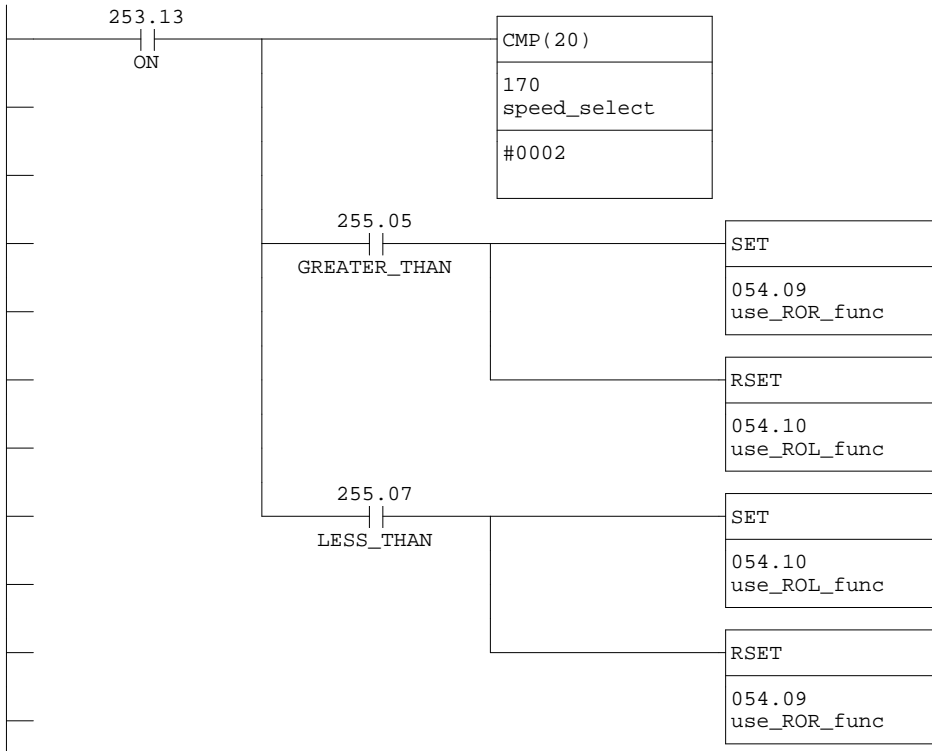

Main 16 - Outputs

Network 1 - Lower "A"

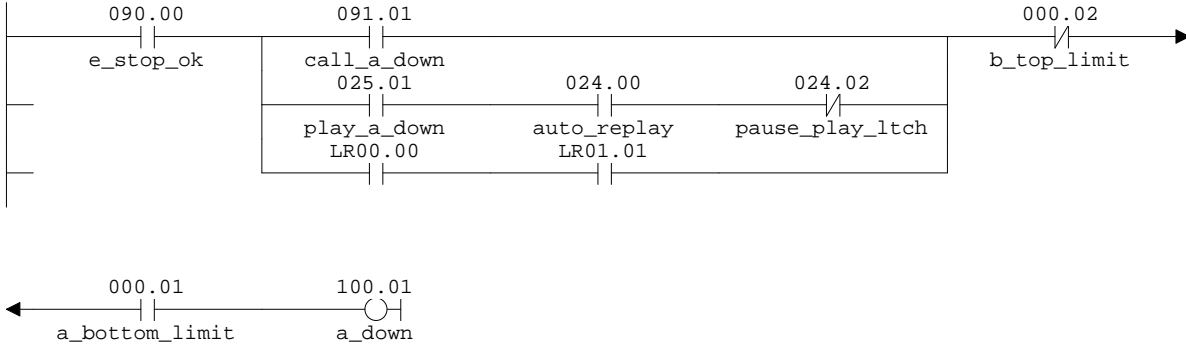

Network 2 - Raise "A"

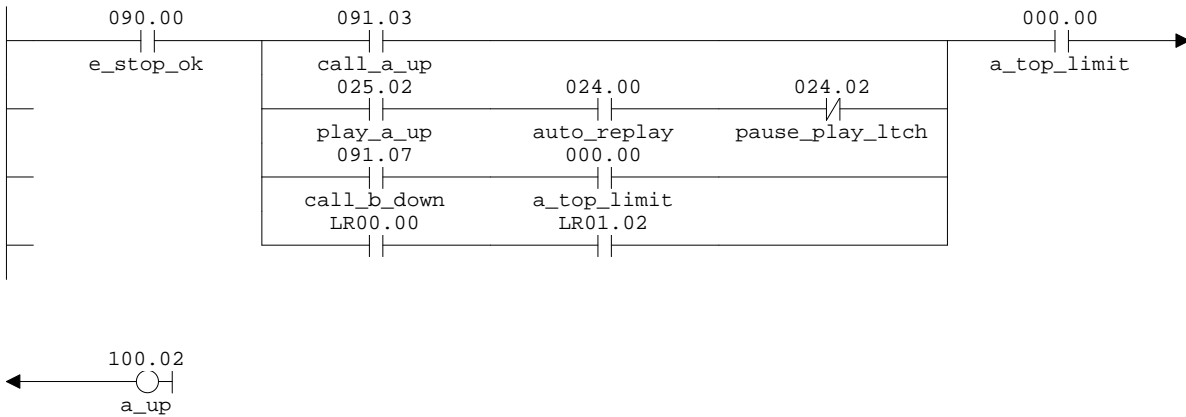

Network 3 - Run mixer

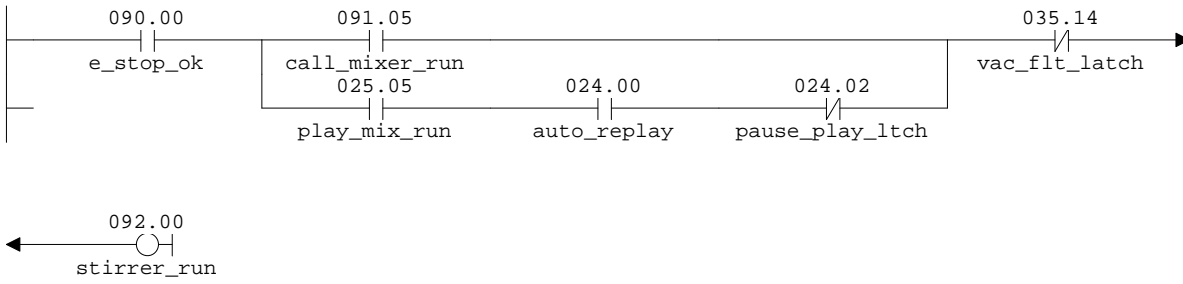

Network 4 - Lower "B"

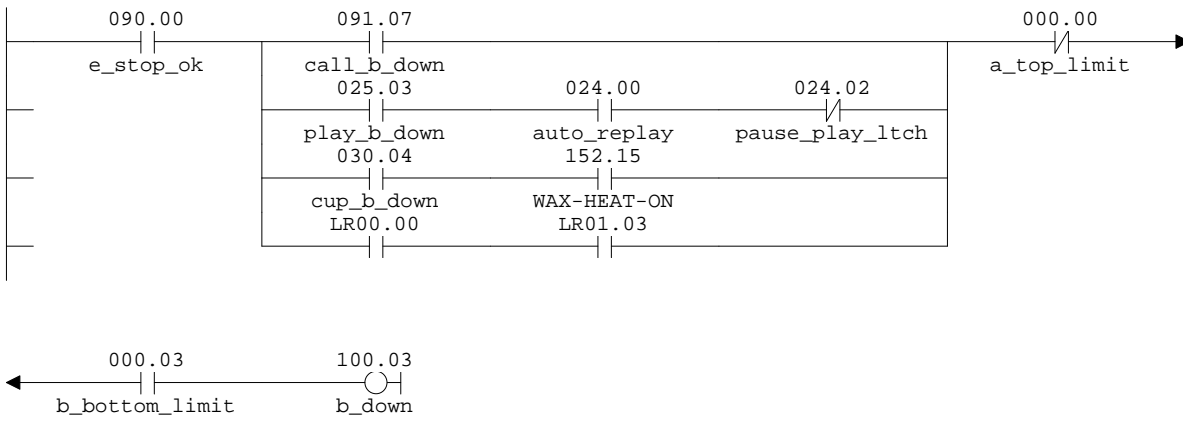

Network 5 - Raise "B"

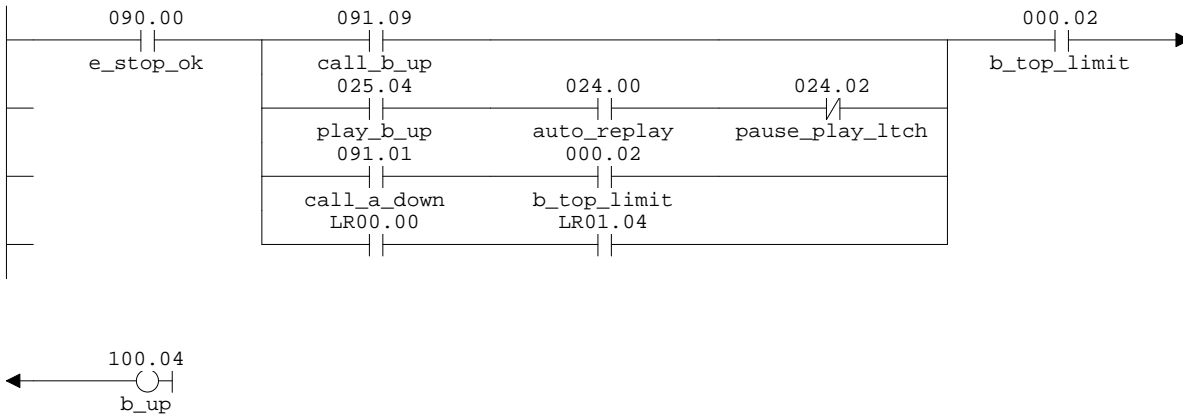

Network 6 - Leak slow

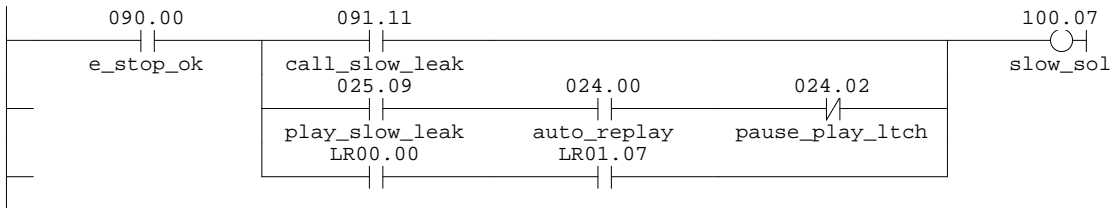

Network 7 - Leak fast

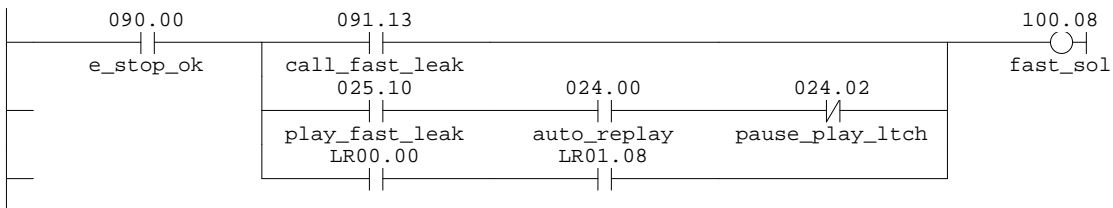

Network 8 - Pump

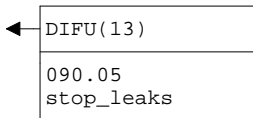
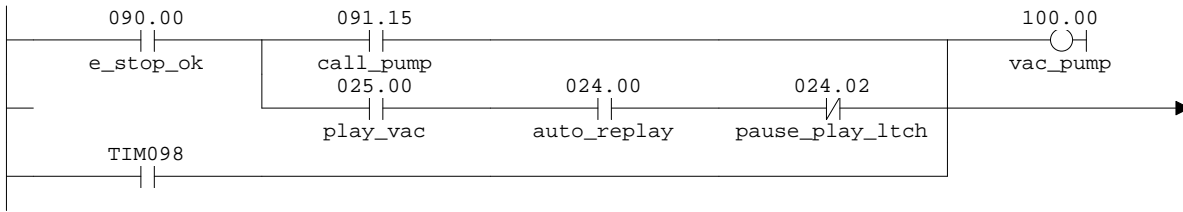

Network 9 - Hoist up

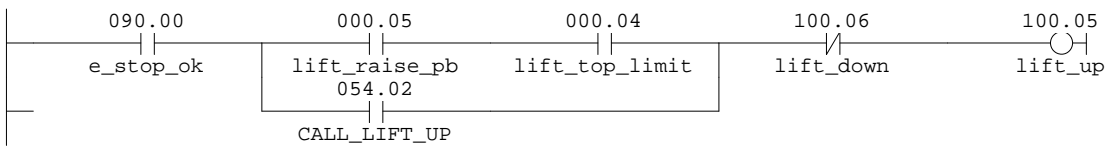

Network 10 - Hoist down

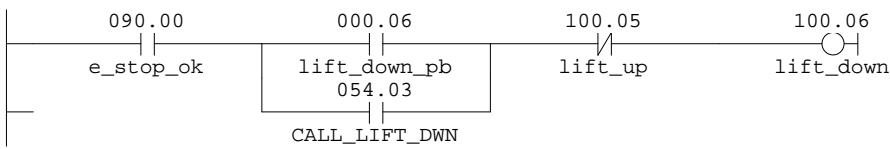

Network 11 - External Alarm

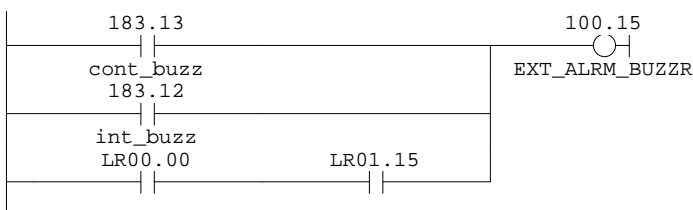

Main 17 - Speed output

Network 1 - Default Lo

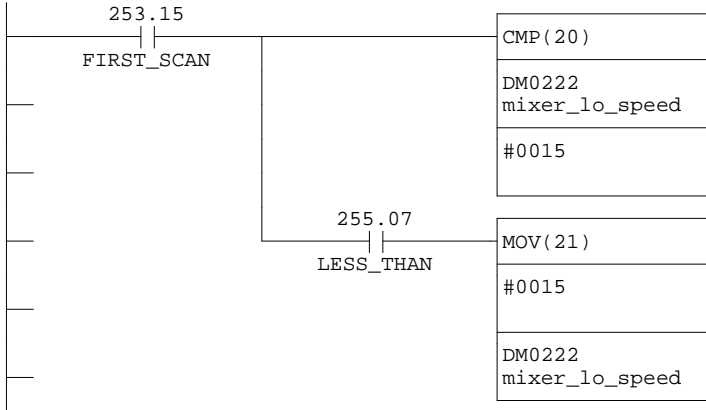

Network 2 - Default Lo

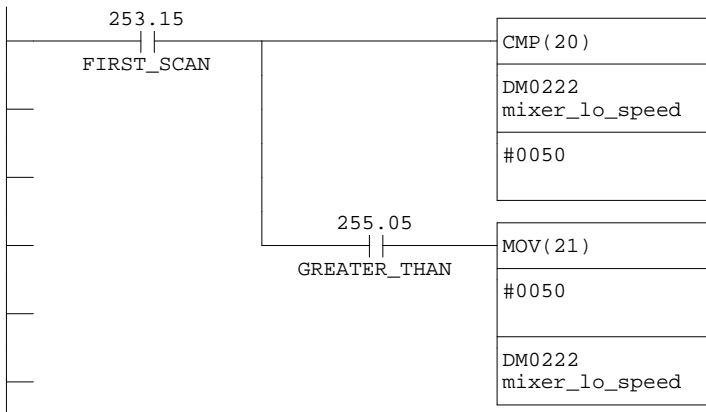

Network 3 - Default Med

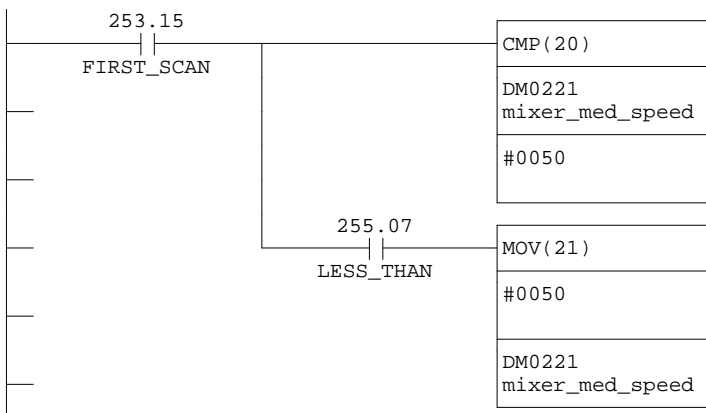

Network 4 - Default Med

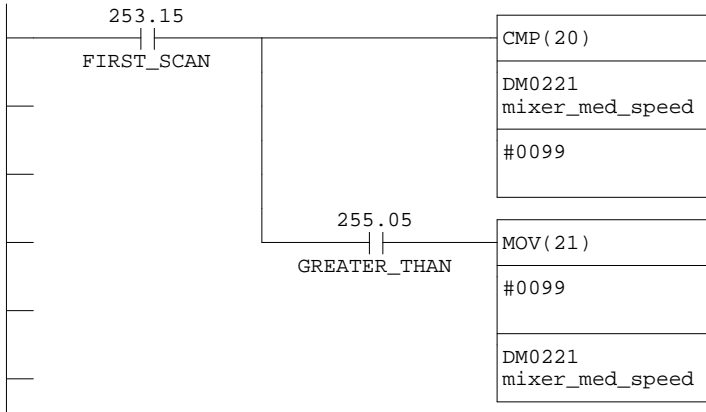

Network 5 - Default Hi

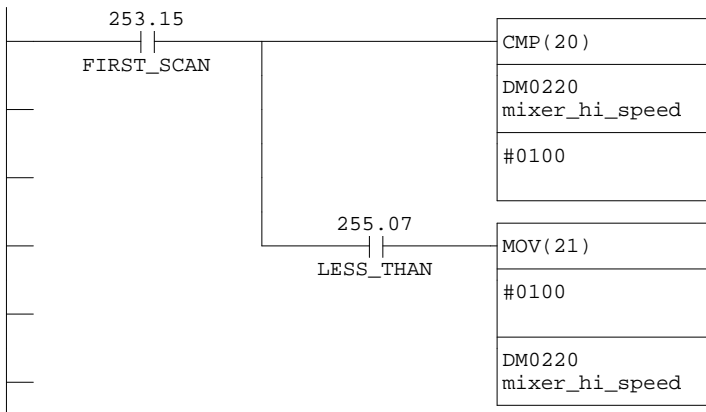

Network 6 - Default Hi

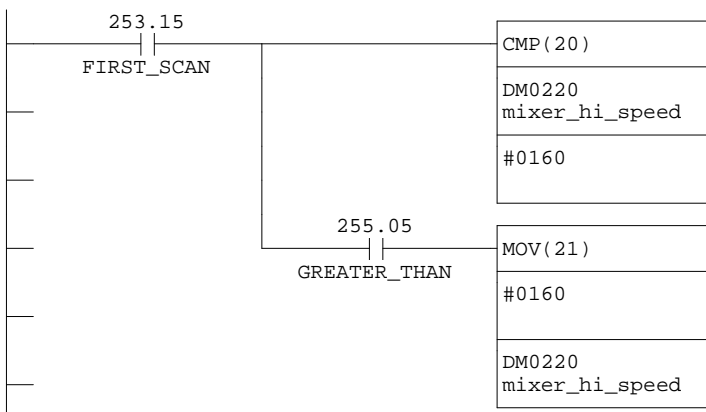

Network 7 - Hi

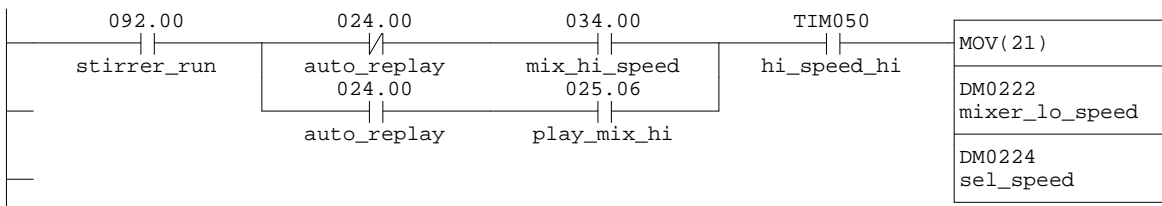
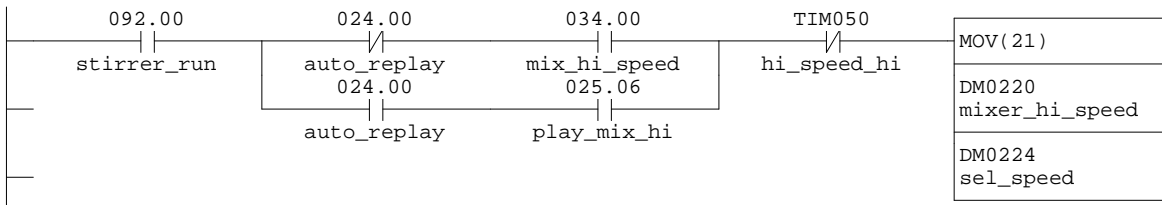
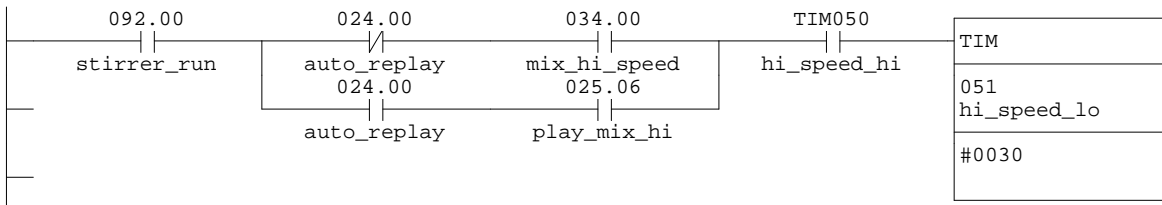
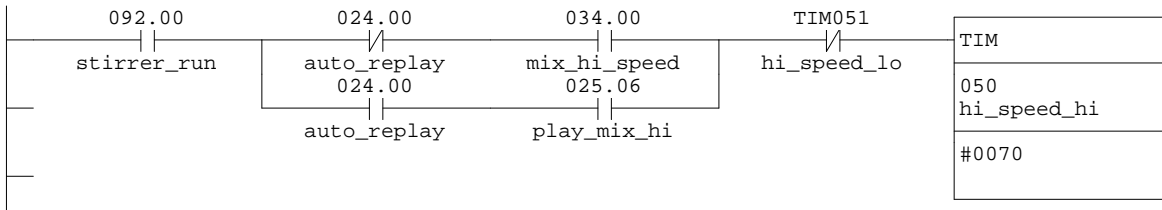

Network 11 - Med

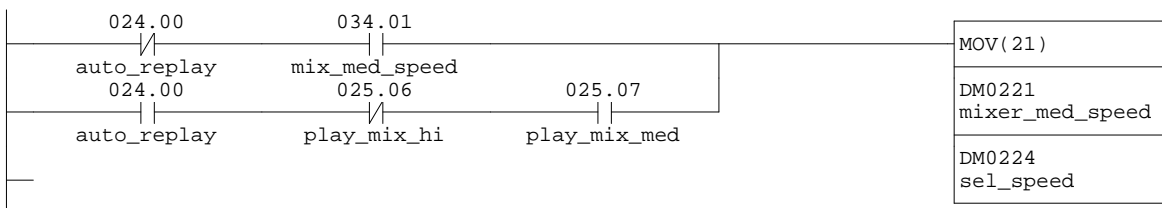



Network 12 - Lo

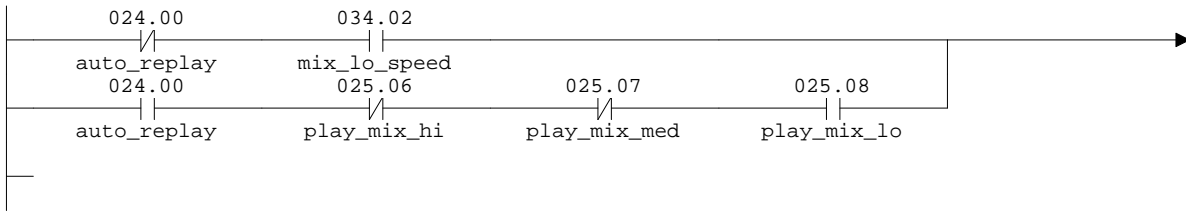

← MOV(21)
DM0222 mixer_lo_speed
DM0224 sel_speed

Network 13 - Max speed

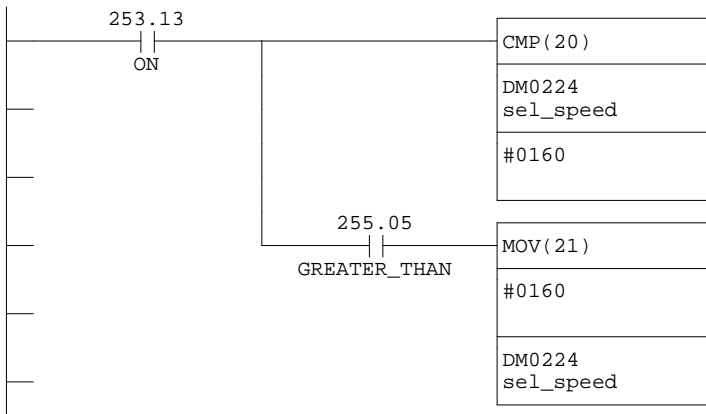

Network 14 - Set scaling



Network 15 - Scale output

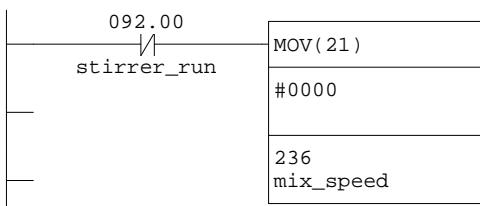
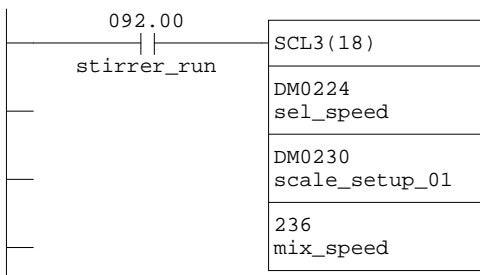

Main 18 - Indicators

PB status lamps etc.

Network 1 - A down

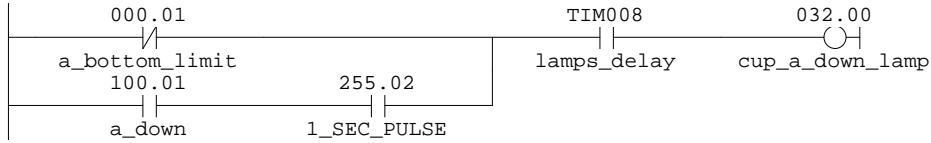

Network 2 - A up

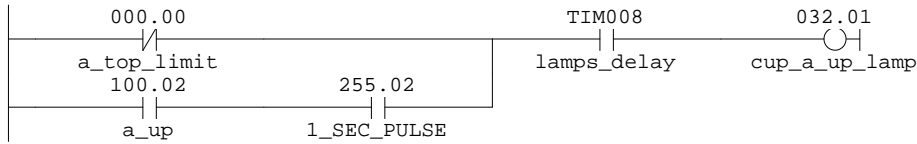

Network 3 - Run mixer

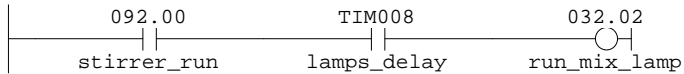

Network 4 - Mixer speed



Network 5 - B down

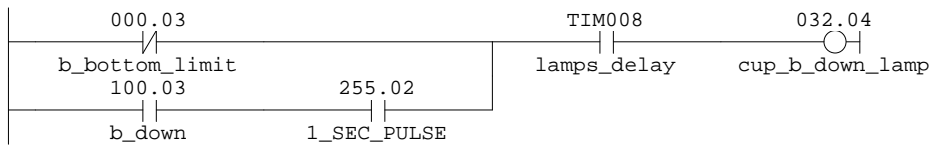

Network 6 - B up

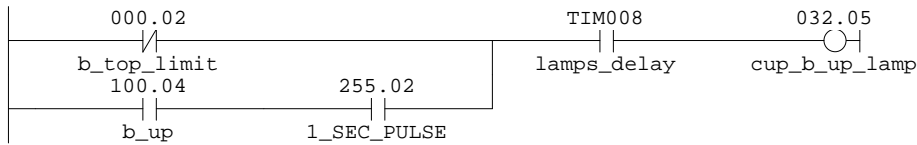

Network 7 - Slow leak

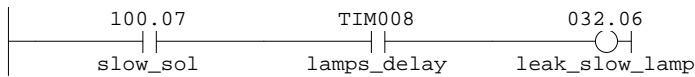

Network 8 - Fast leak

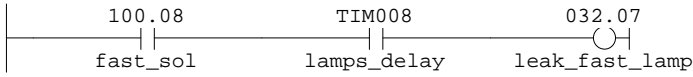

Network 9 - Pump run

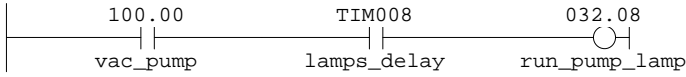

Main 19 - Auto record

Network 1 - Erase active

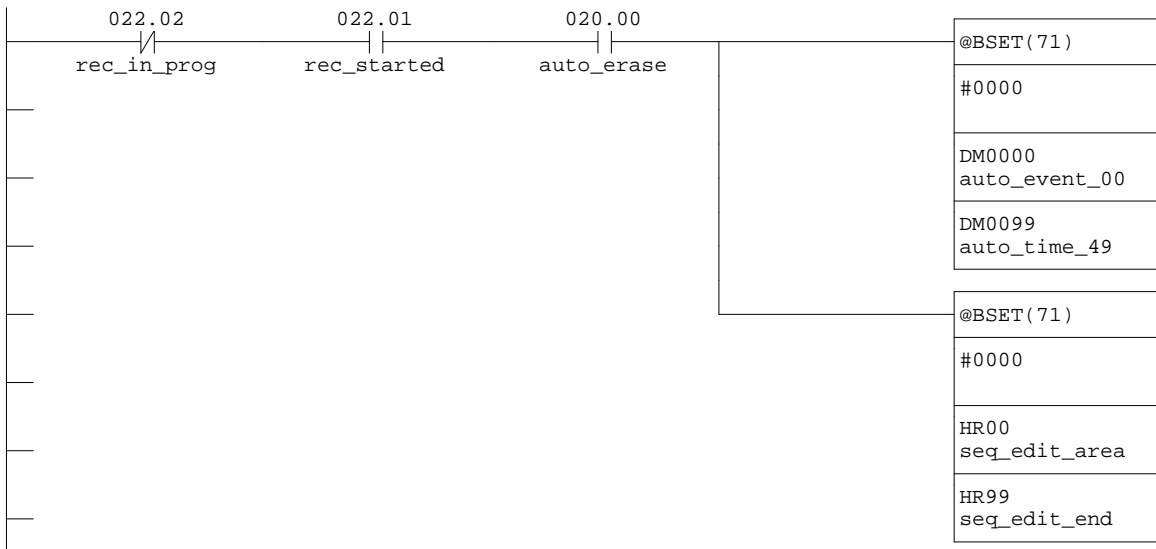

Network 2 - Record start

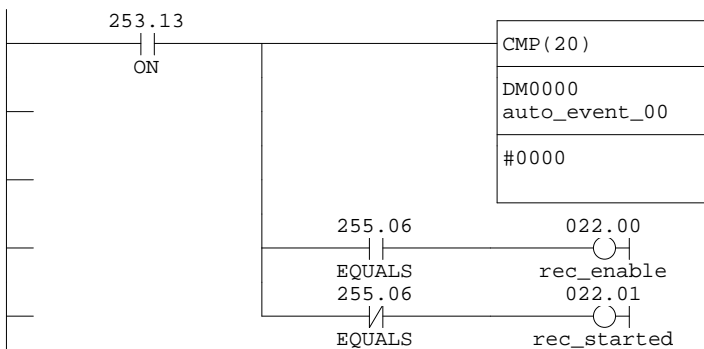

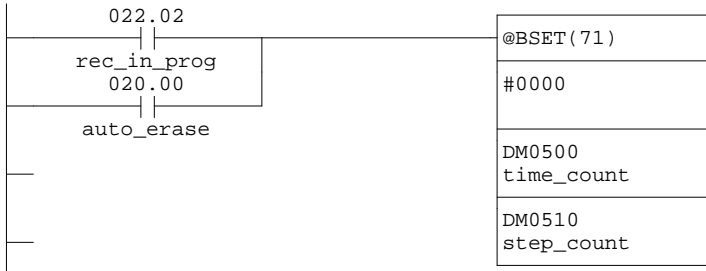
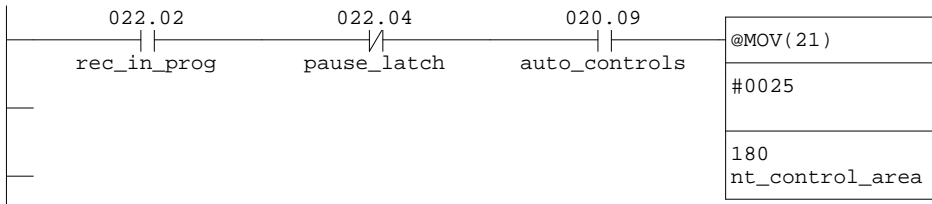
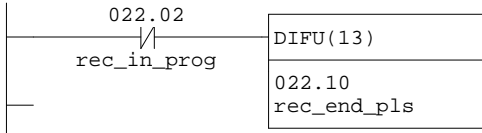
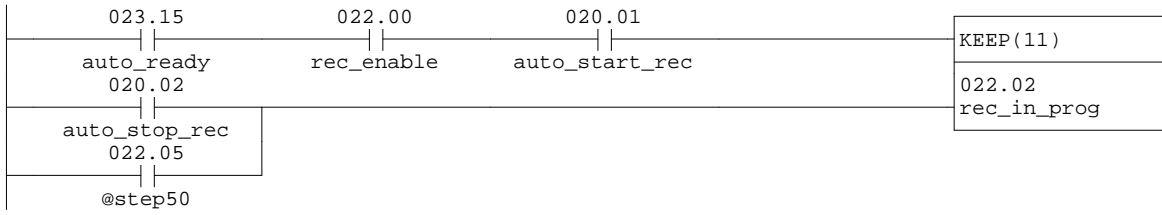

Network 7 - Pause?

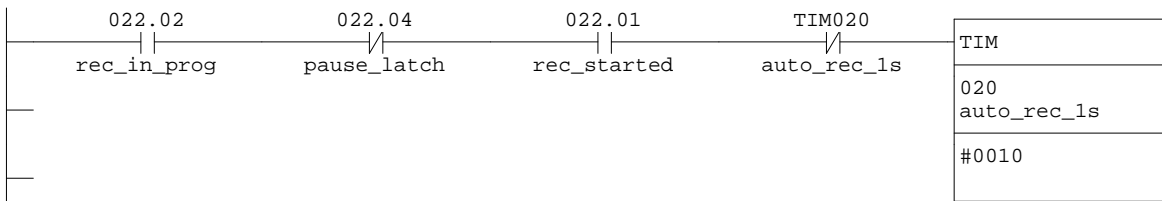
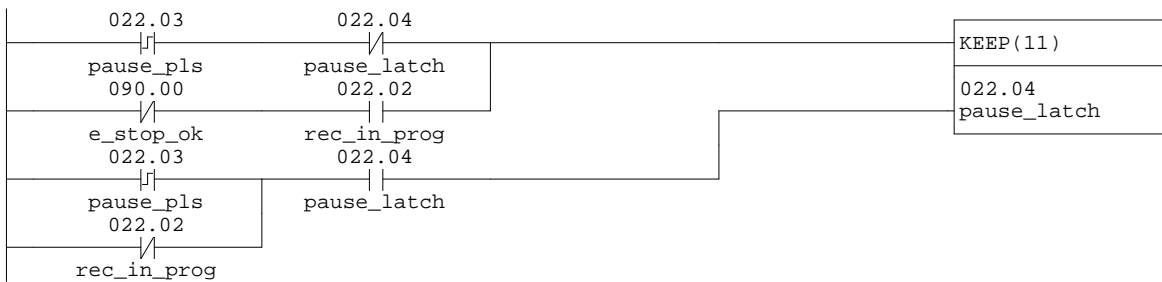
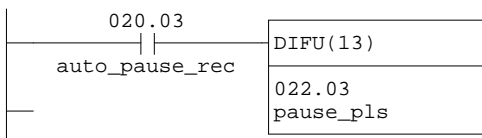

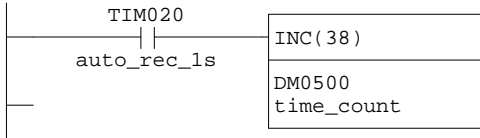

Network 12 - Stop lamp

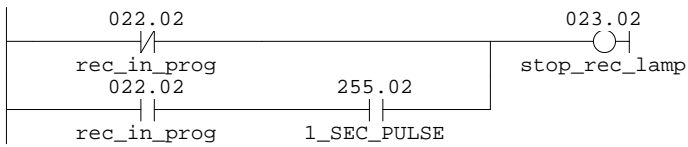

Network 13 - Start lamp

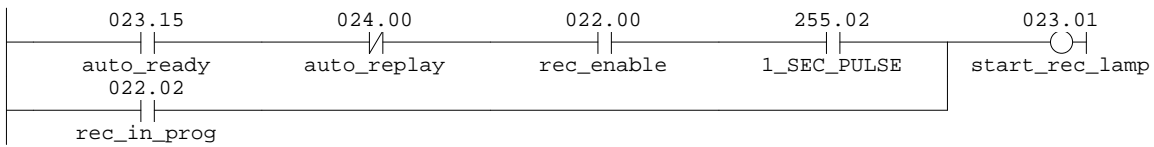

Network 14 - Erase pb+lamp

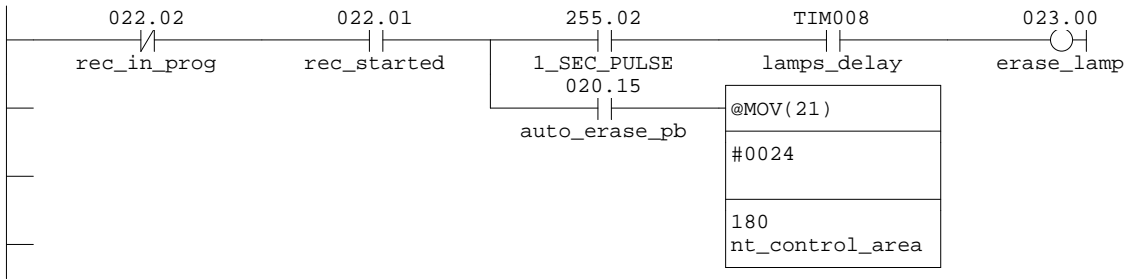

Network 15 - Pause lamp

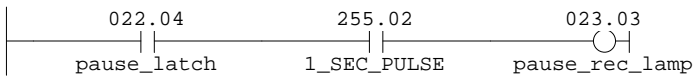

Network 16 - Save pointers

Set the recipe data store checking pointers

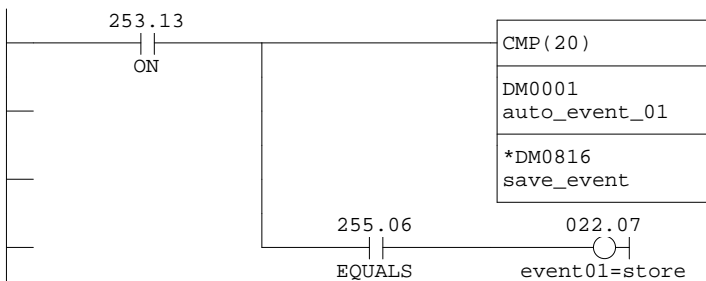
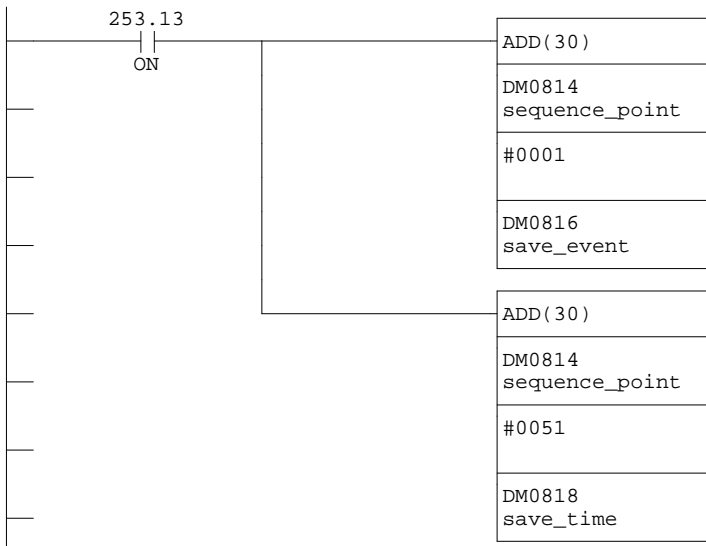

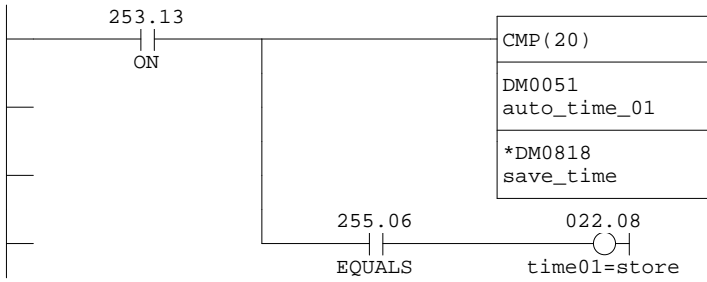

Network 19 - Save lamp

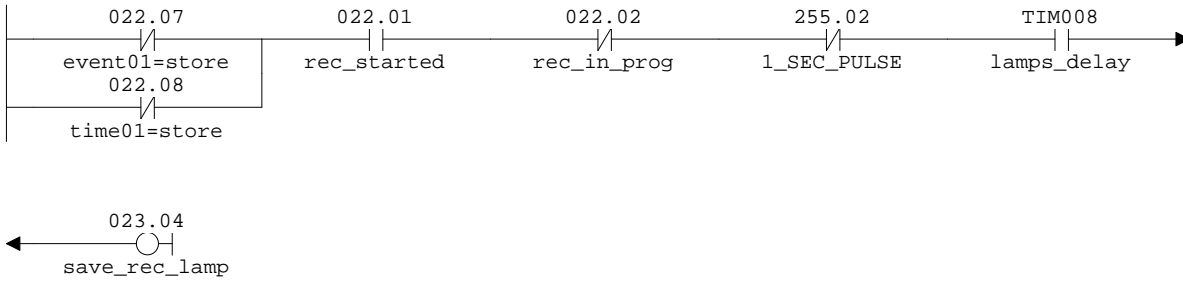

Network 20 - Show cont. lamp

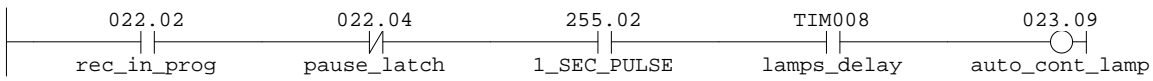

Network 21 - Record bits

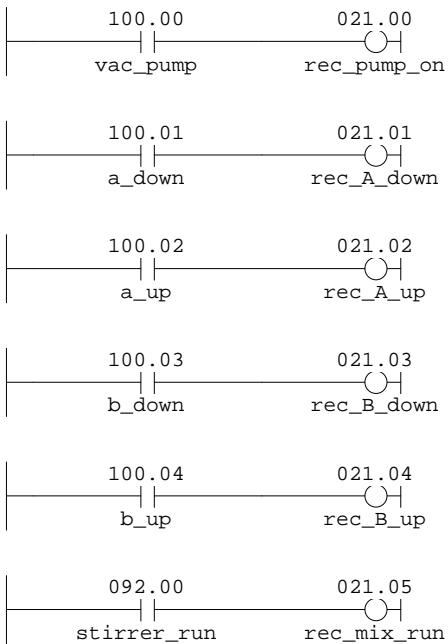



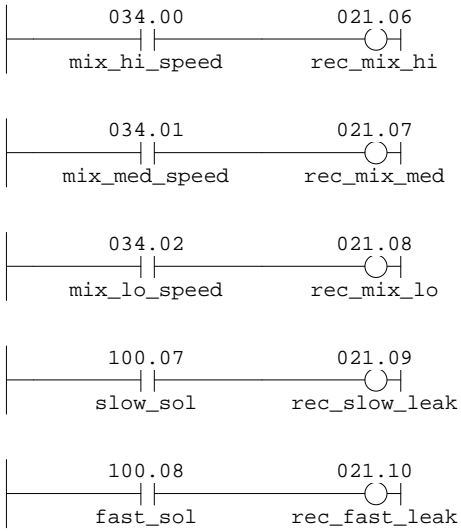

Network 32 - Set tim pointer

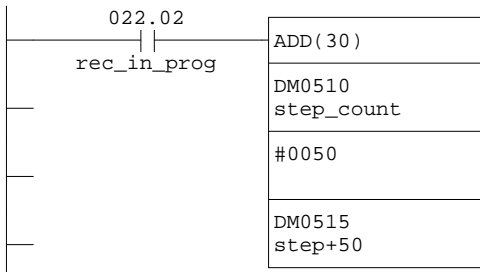

Network 33 - Record segment

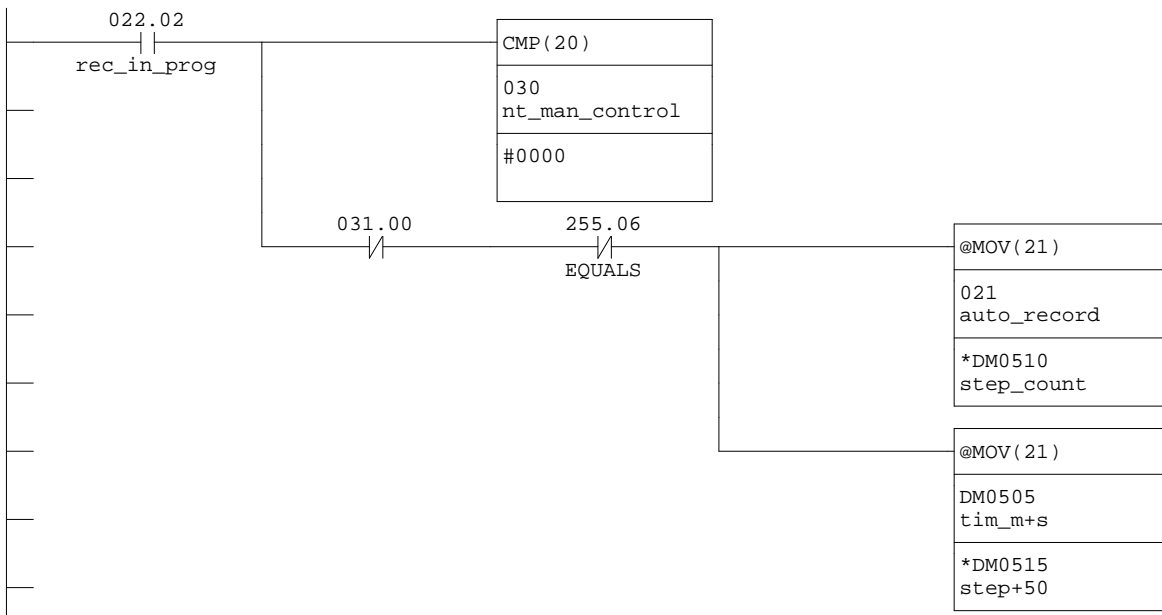

Network 34 - Goto next step

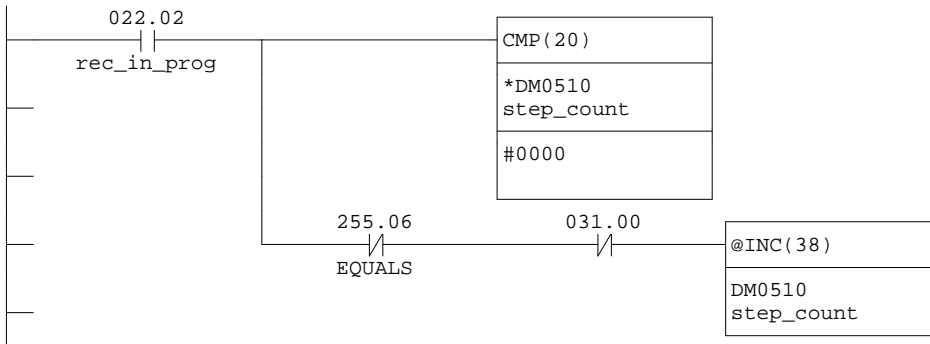

Network 35 - Last step?

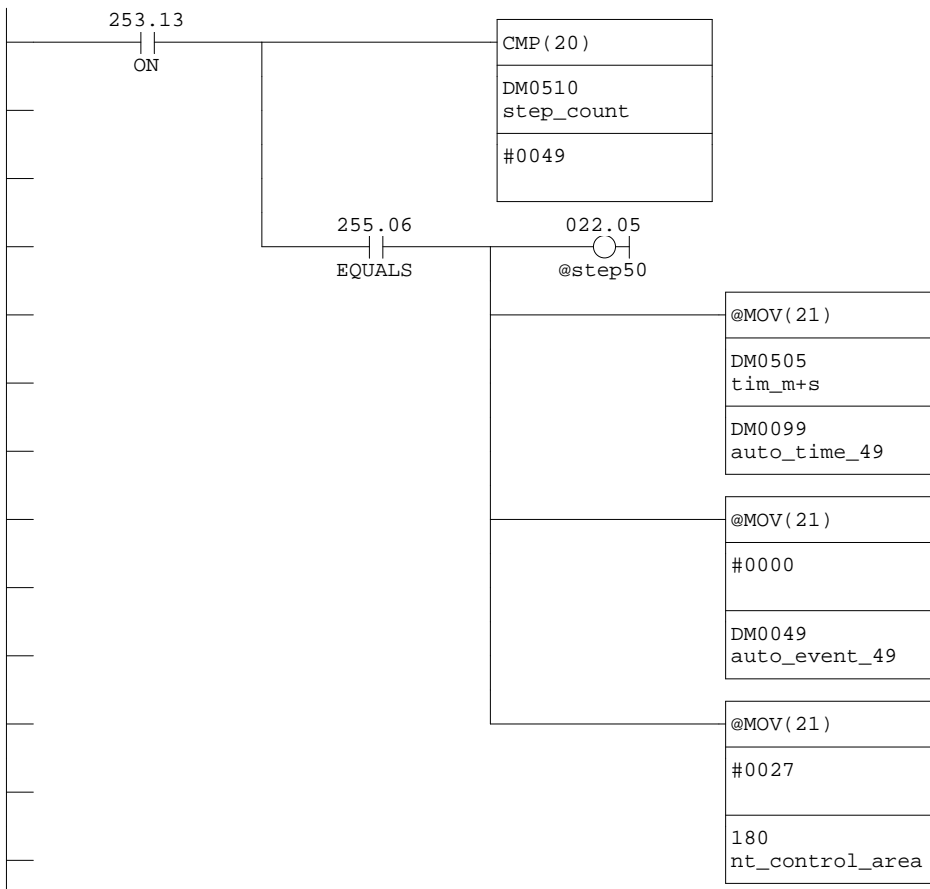

Network 36 - Cycle end

At the cycle end record the time and enter NO actions

NOTE:- MOV command changed to enable clearing of step counter.

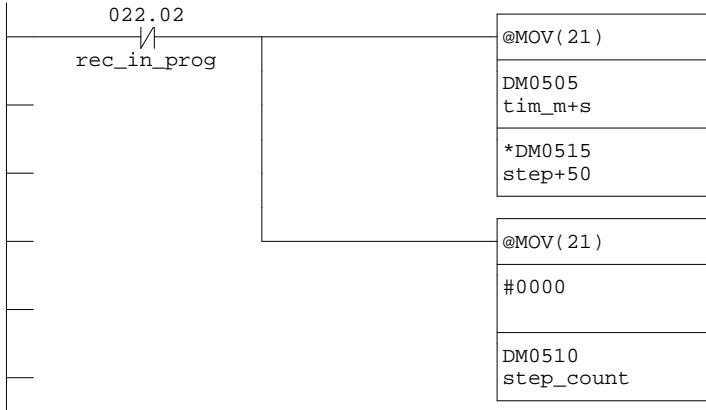

Network 37 - Save auto seq'

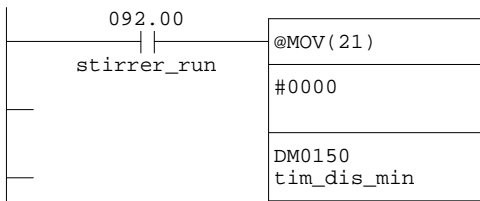
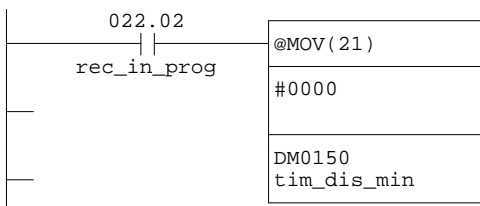
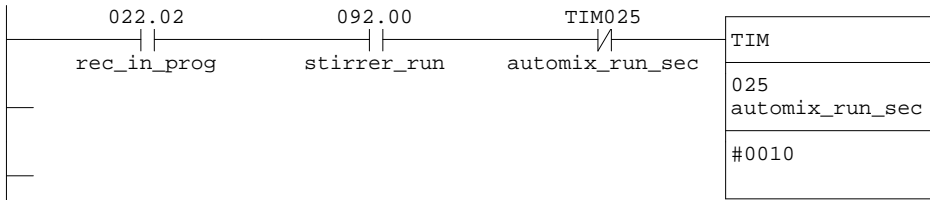
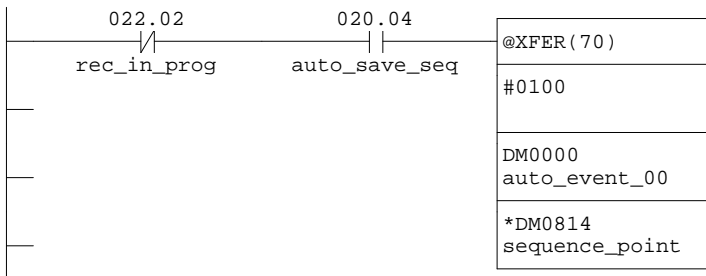

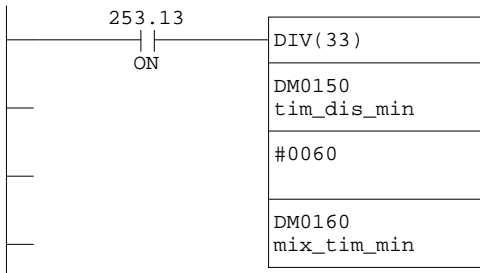
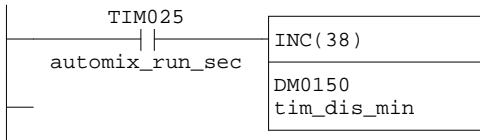

Main 20 - Auto Replay

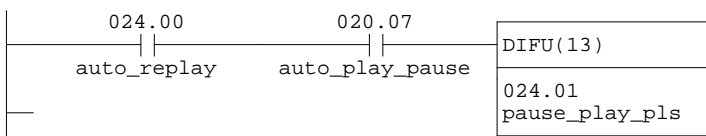
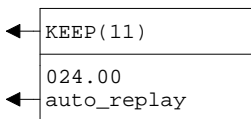
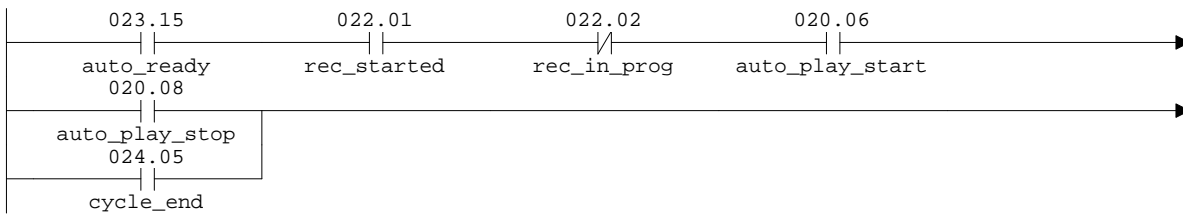
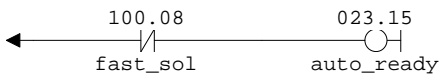
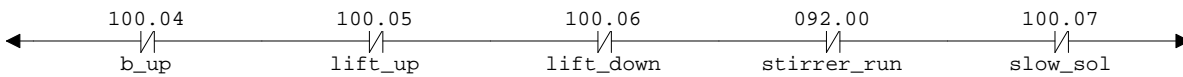
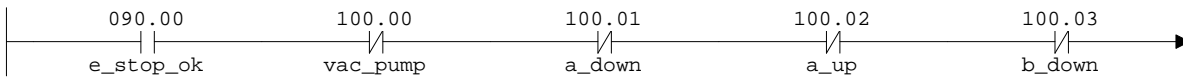

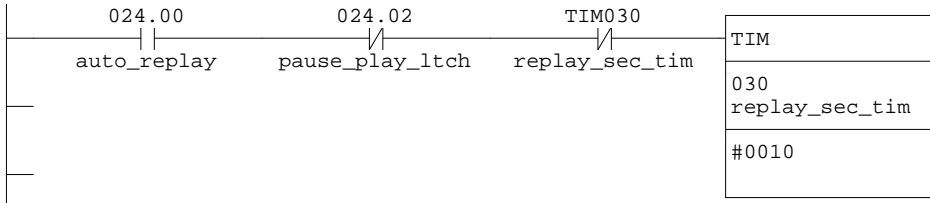
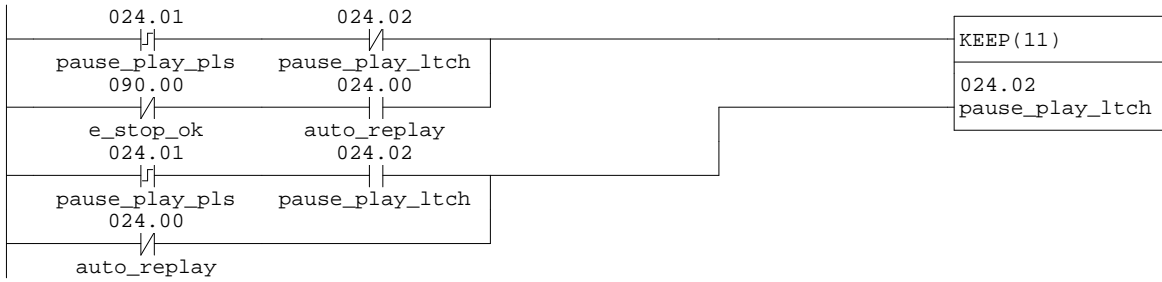

Network 6 - Time in seconds

Auto replay time in seconds

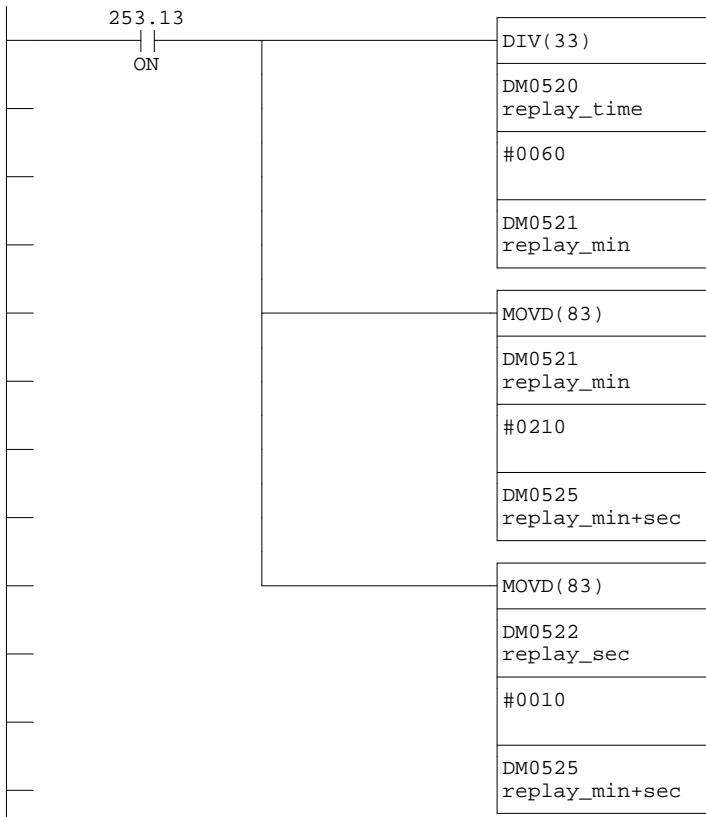
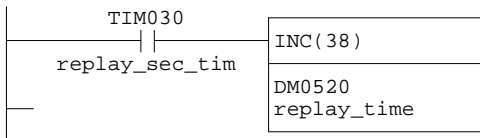

Network 8 - Reset@power on

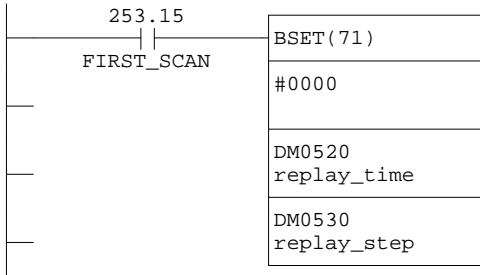

Network 9 - Reset timer

Reset auto replay timer at auto relay start

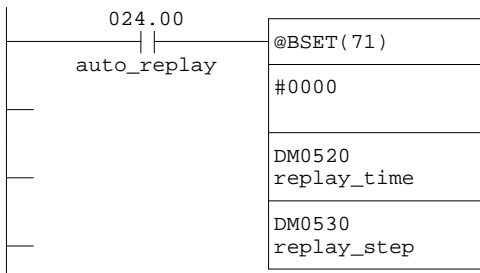

Network 10 - Reset timer

Reset auto replay timer at auto relay stop

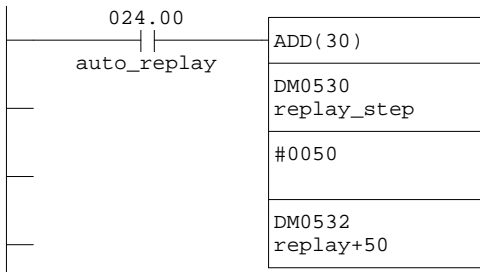
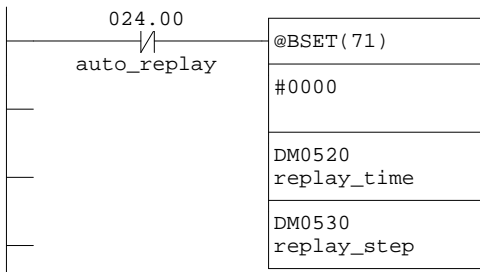

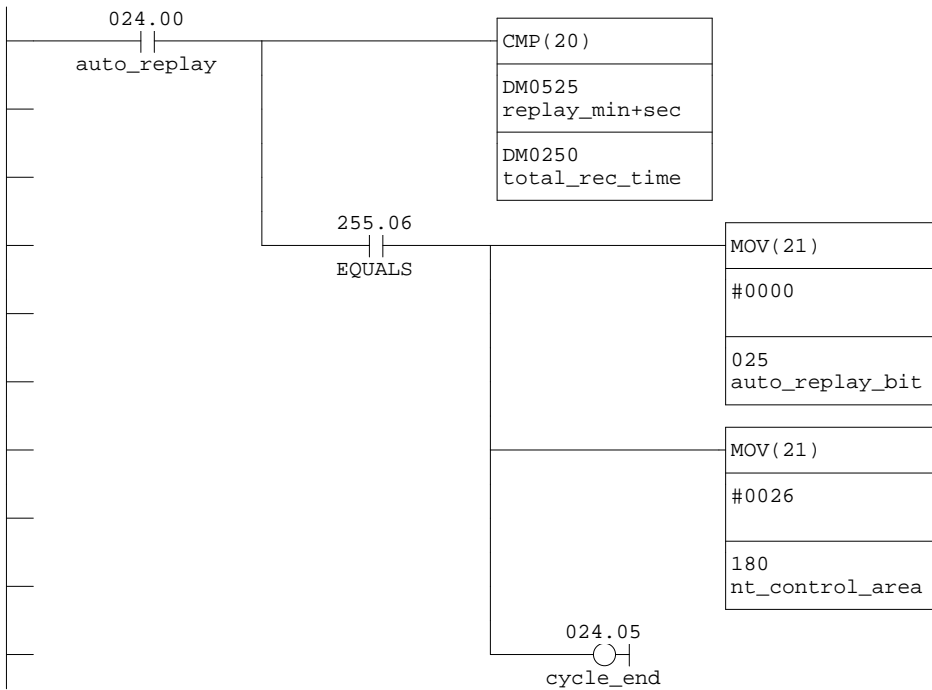
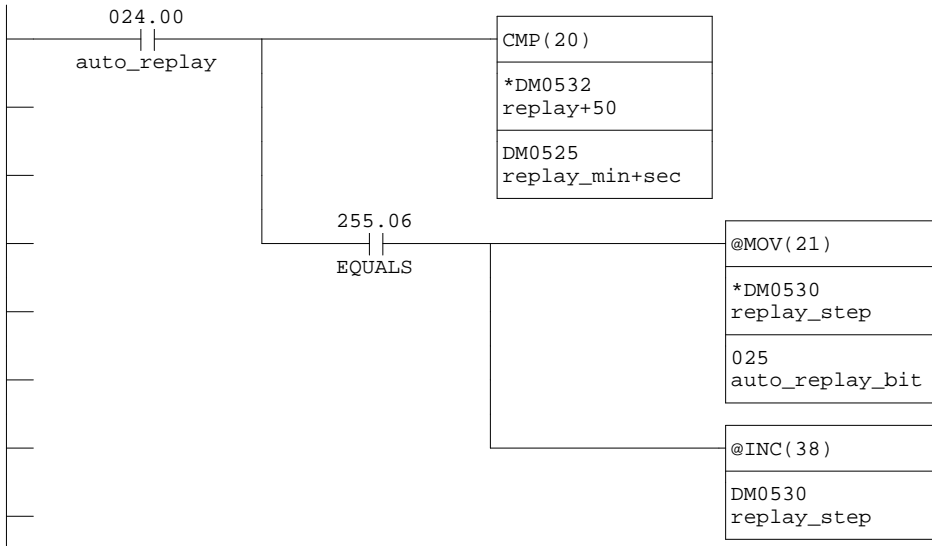

Network 14 - Stop lamp

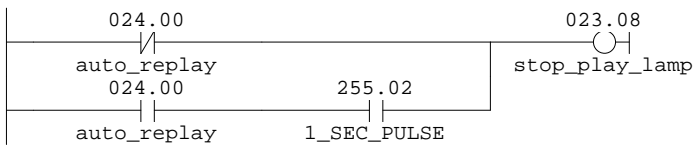

Network 15 - Start lamp

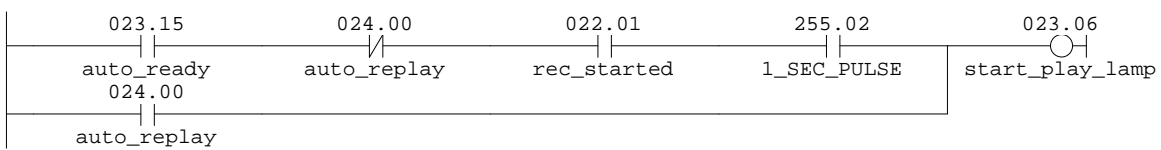

Network 16 - Pause lamp

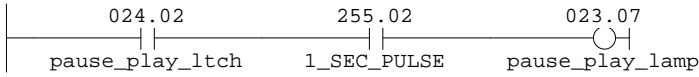

Network 17 - Rec Tim in Secs

Convert total recipe time to seconds.

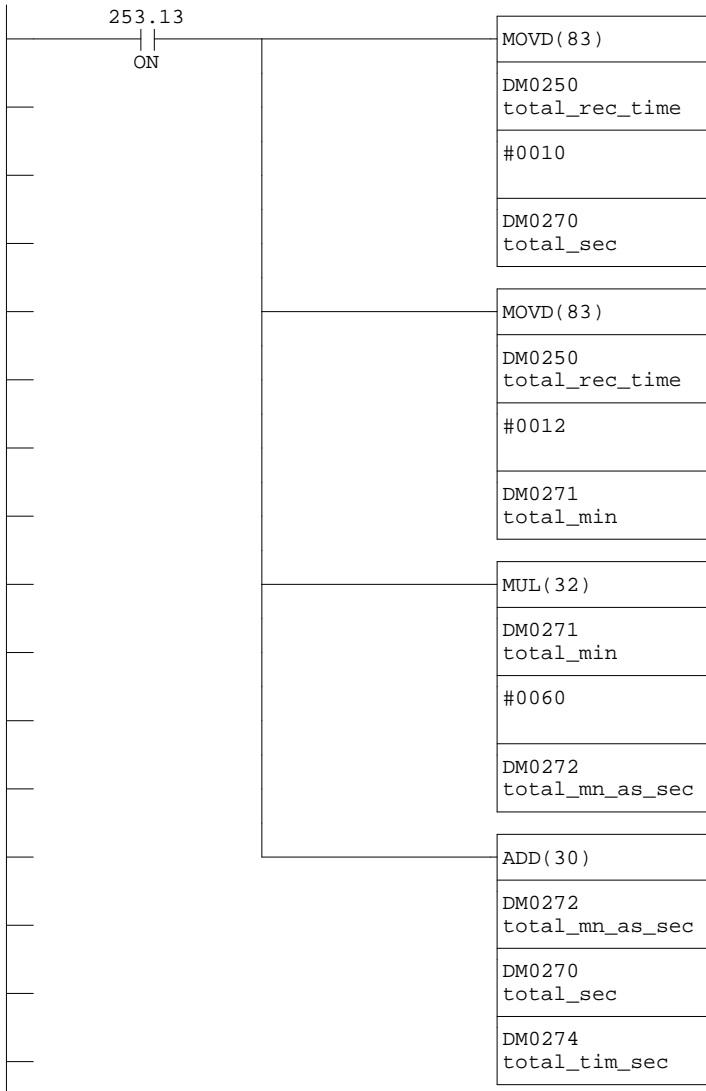

Network 18 - Countdown sec

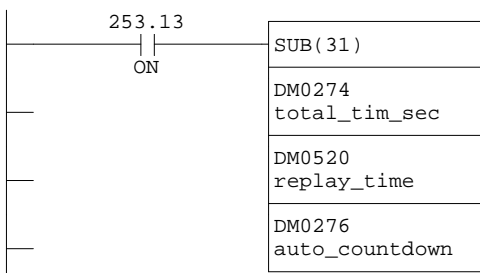



Network 19 - C'down min+sec

Convert countdown register to minutes and seconds in one register.

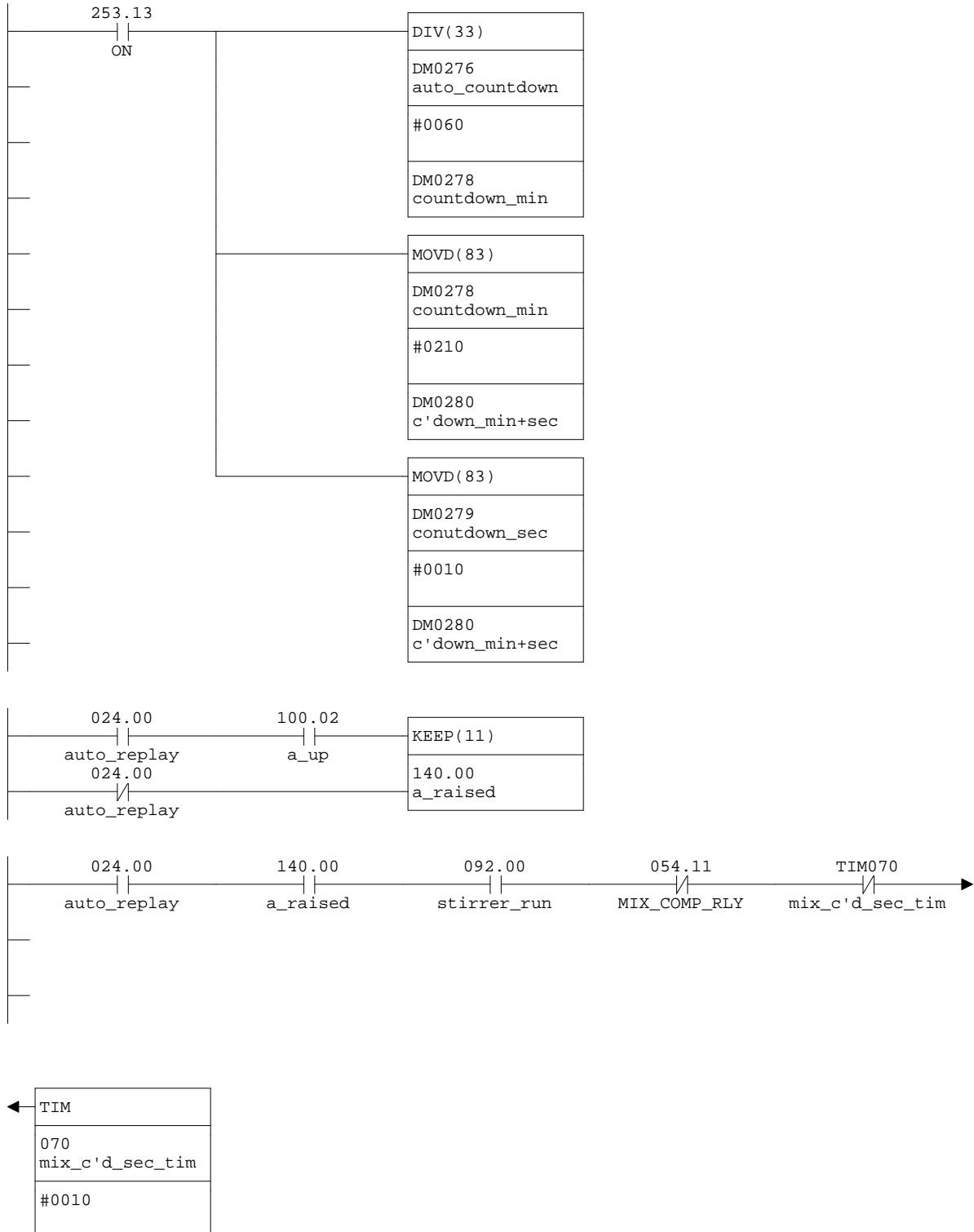

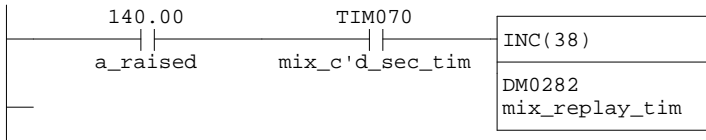

Network 23 - Mix Complete

Mix time complete. Stop countdown.

NOTE:- This rung may need removing. I suspect that the timer should be set to the time it took the mixer to run rather than anything else.

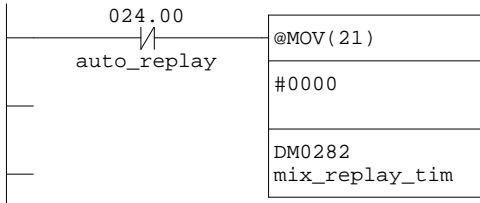
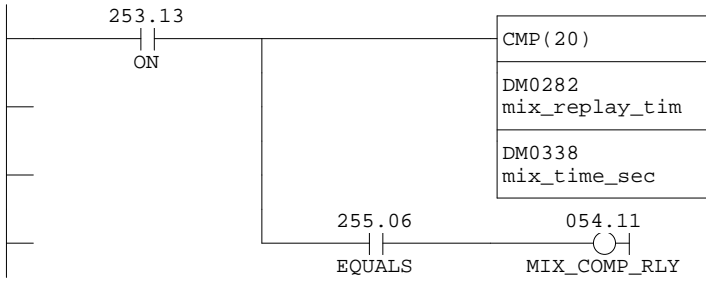



Main 21 - Auto Time+Steps

Detect recipe time and number of steps used

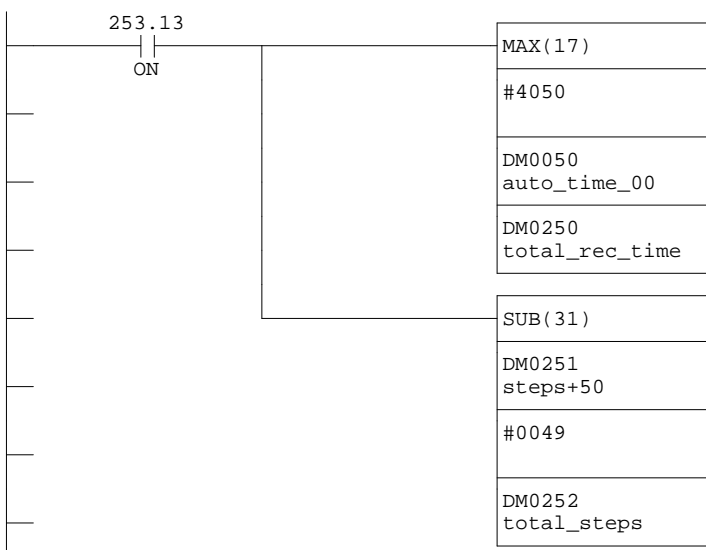

Main 22 - Auto Mix time

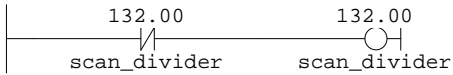

Network 2 - Scan DM's

Scan active recipe

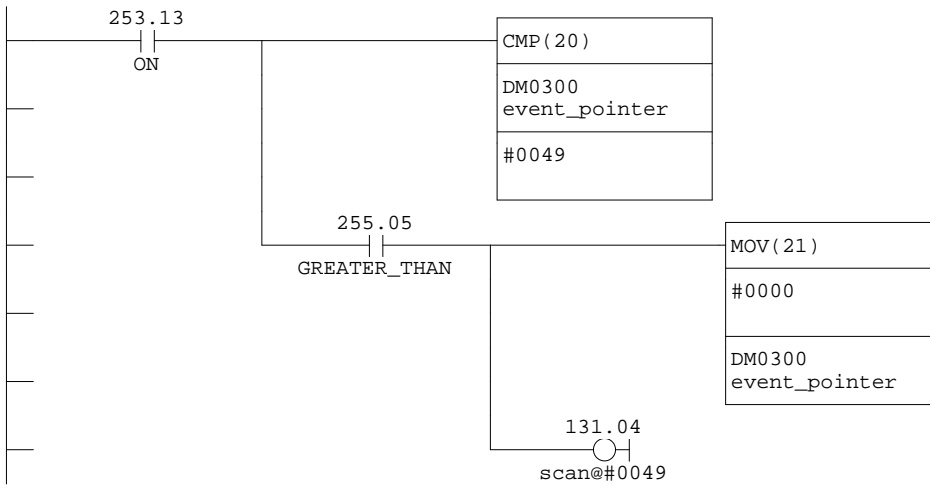
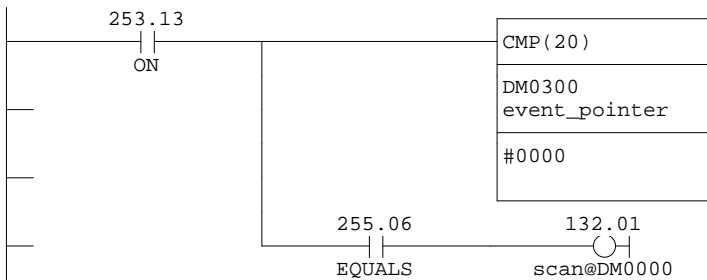
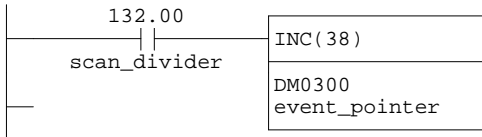

Network 5 - Set tim pointer

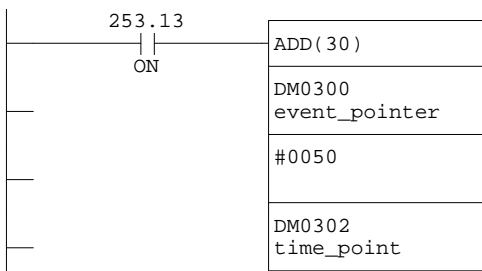

Network 6 - Scan events

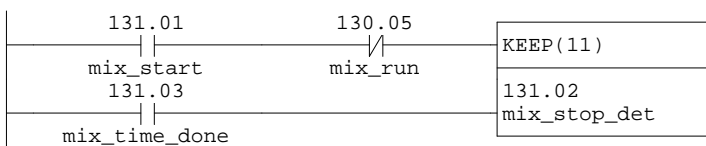
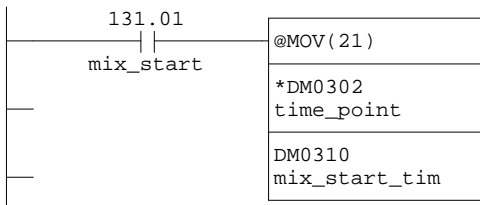
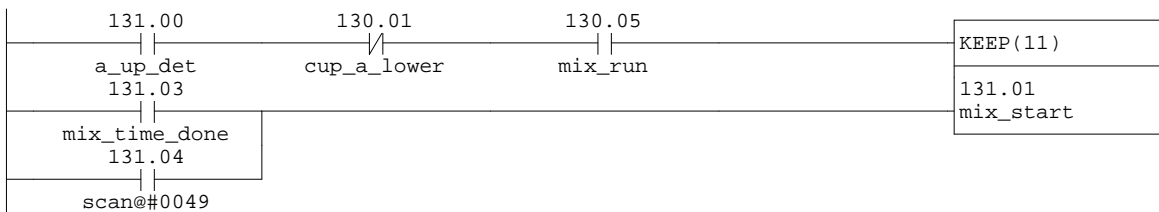
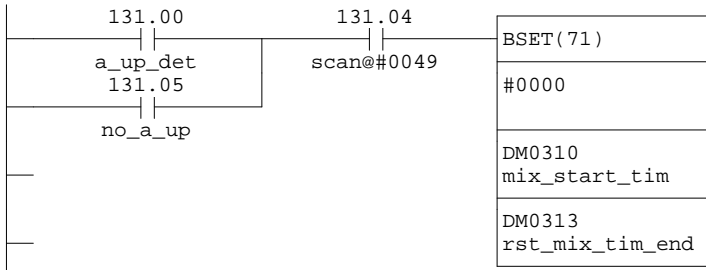
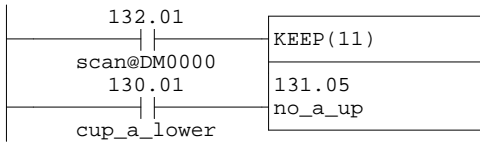
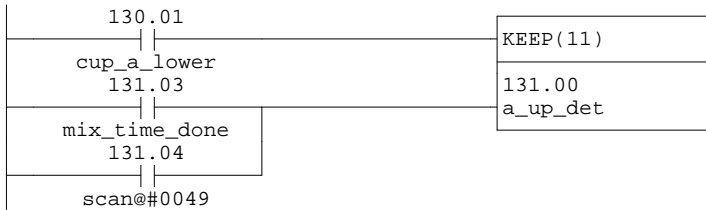
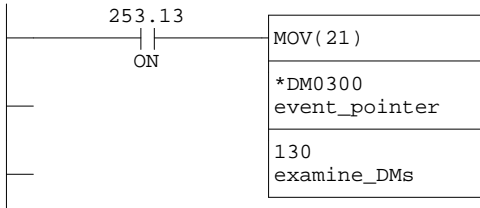

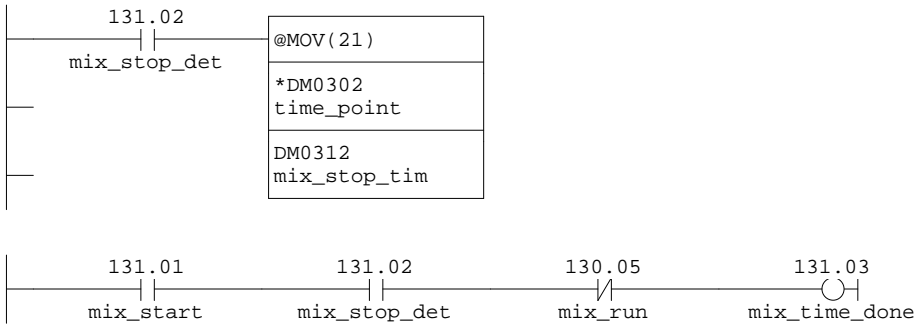

Network 15 - Convert start



Network 16 - Convert stop

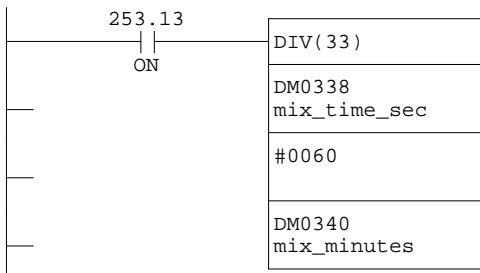
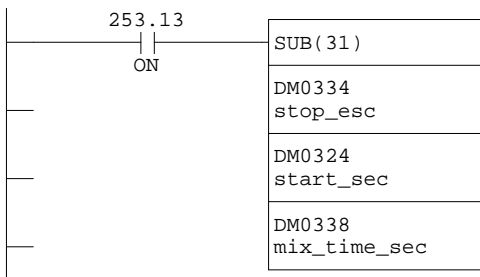

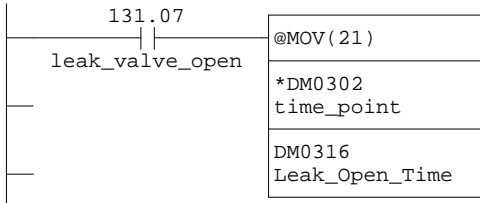
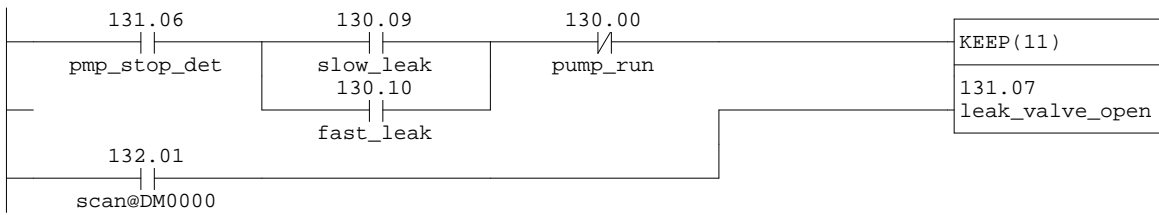
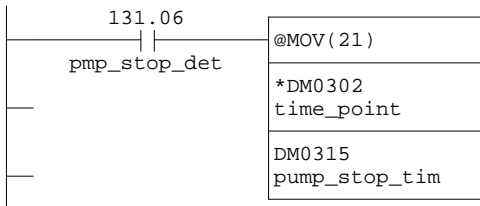
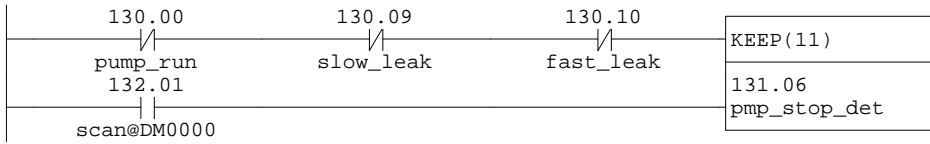



Network 23 - Convert start



Network 24 - Convert stop

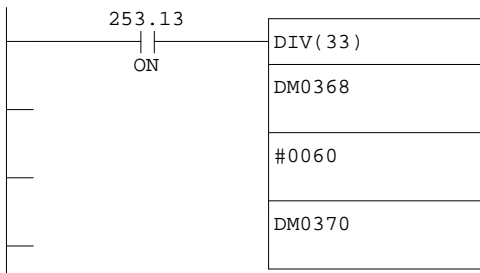
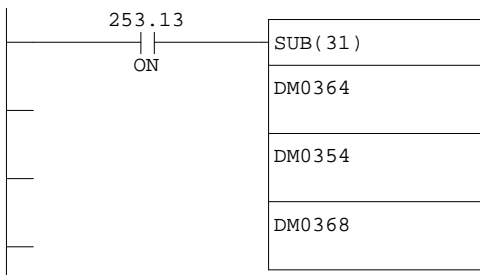

Main 23 - Manual timers

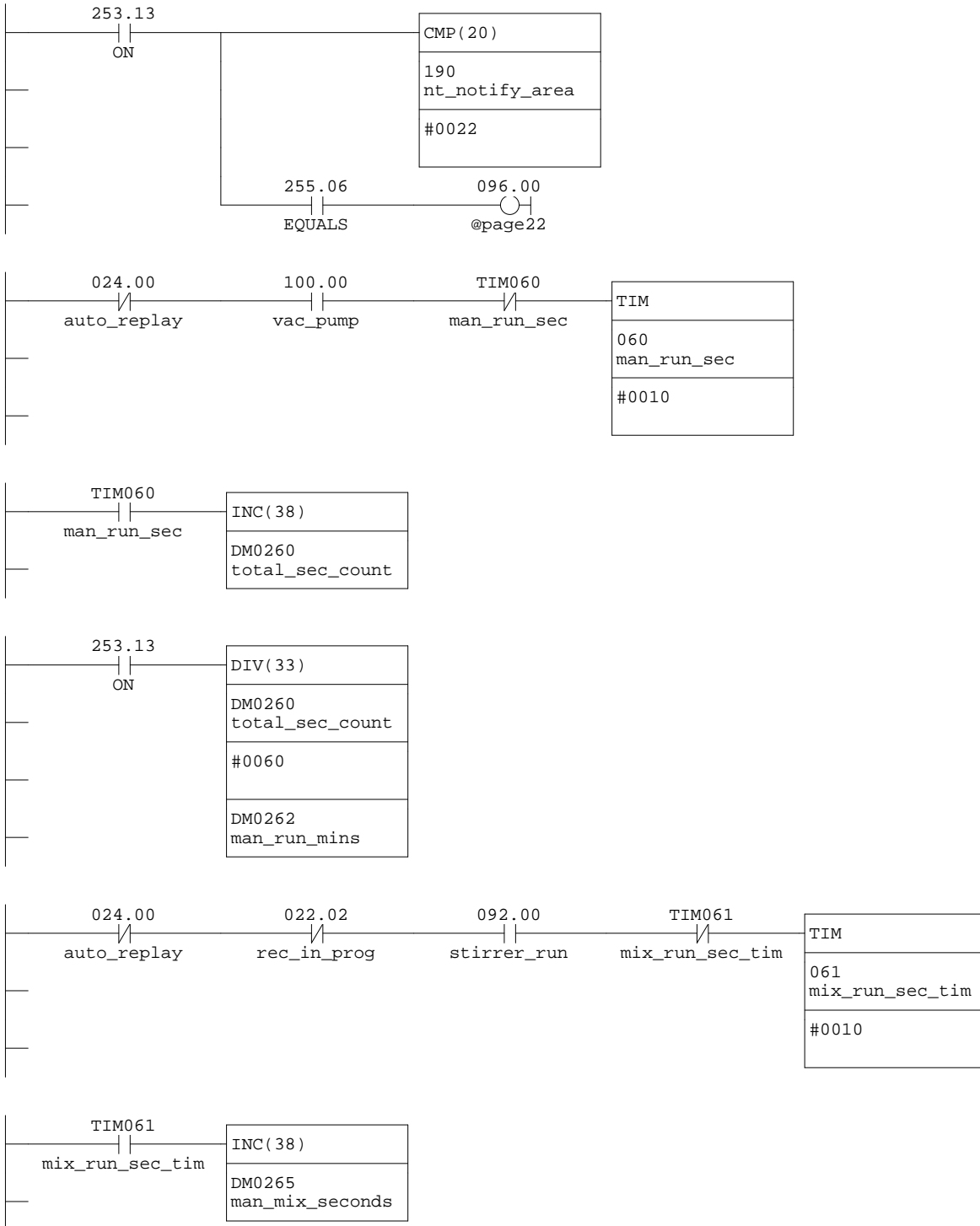

Network 7 - Reset Mix Time

Reset Manual Mixer Timer when starting the mixer.

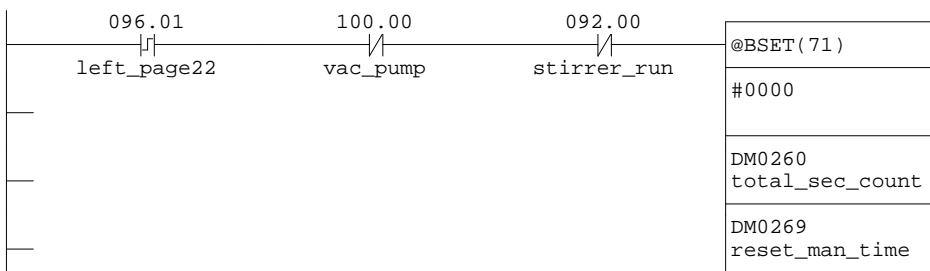
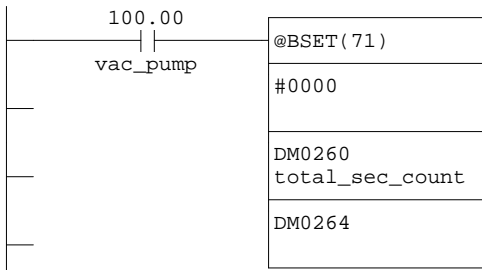
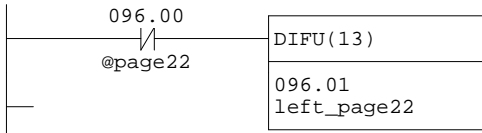
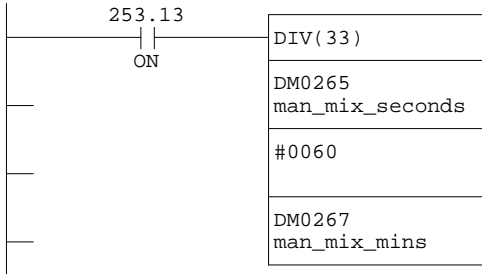
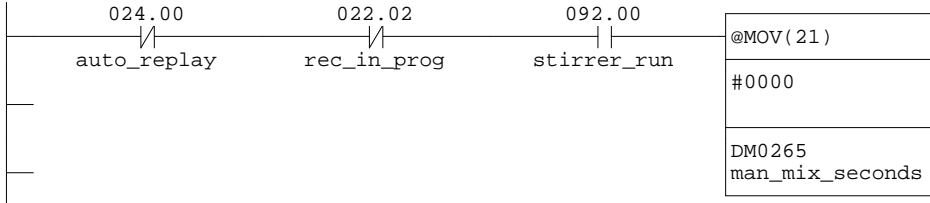

Main 24 - Language

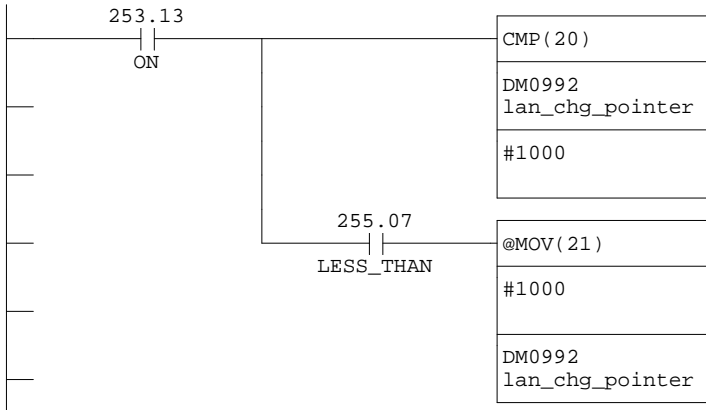

Network 2 - Text

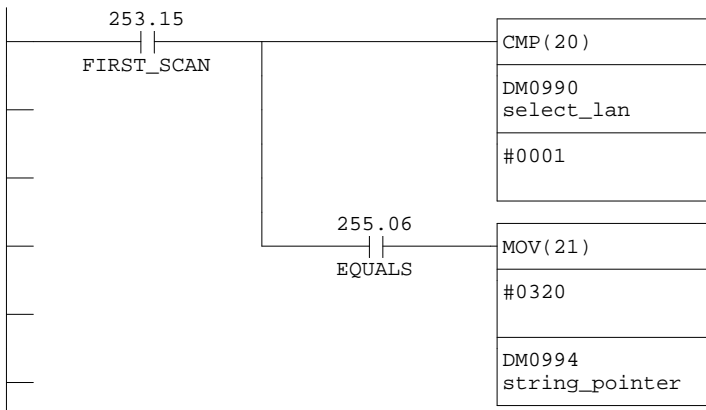
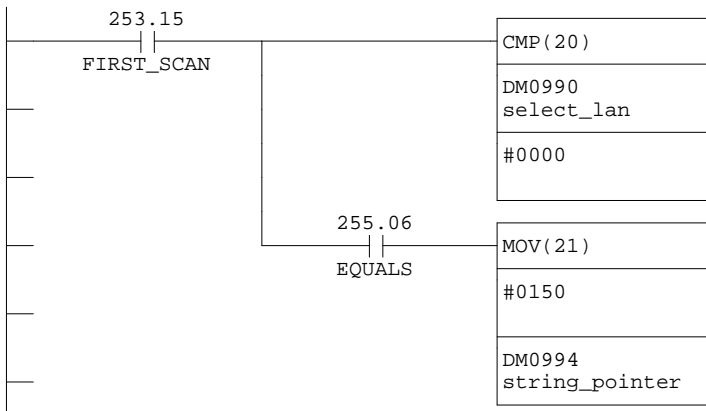
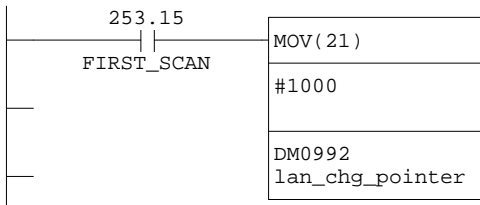

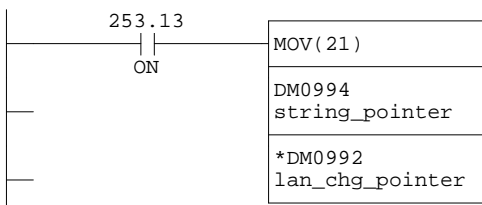
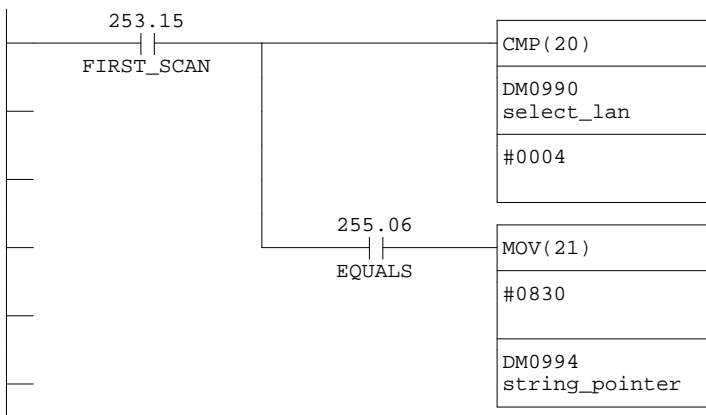
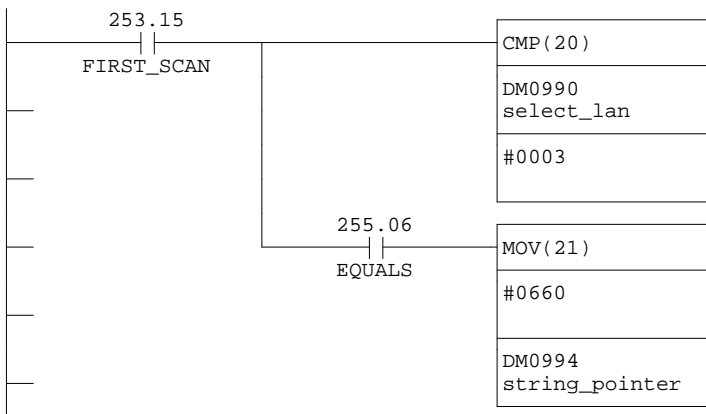
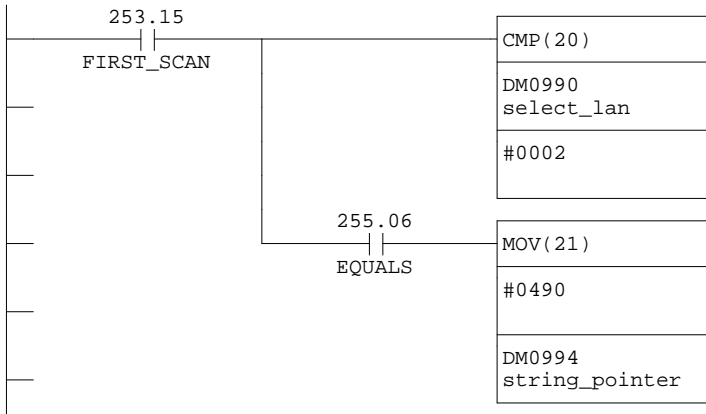

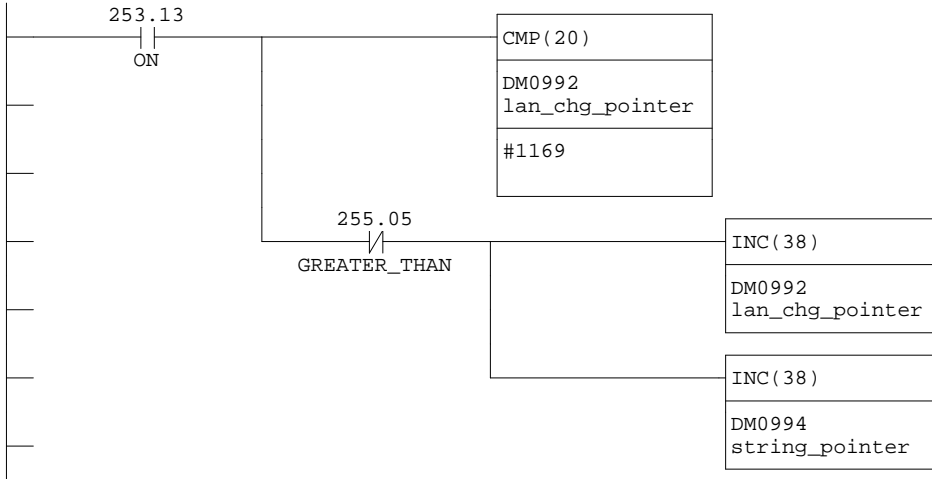

Network 10 - Alarms

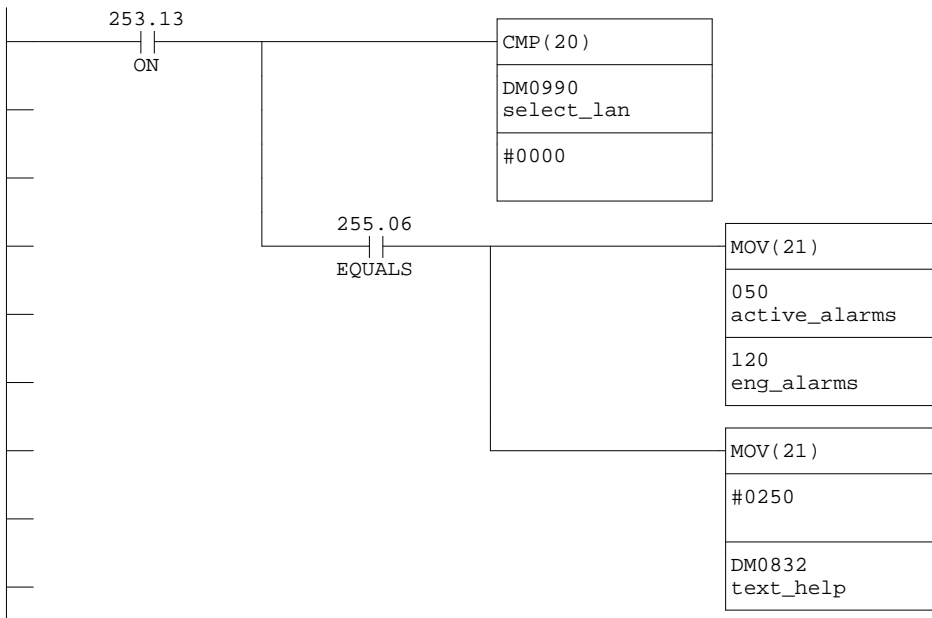

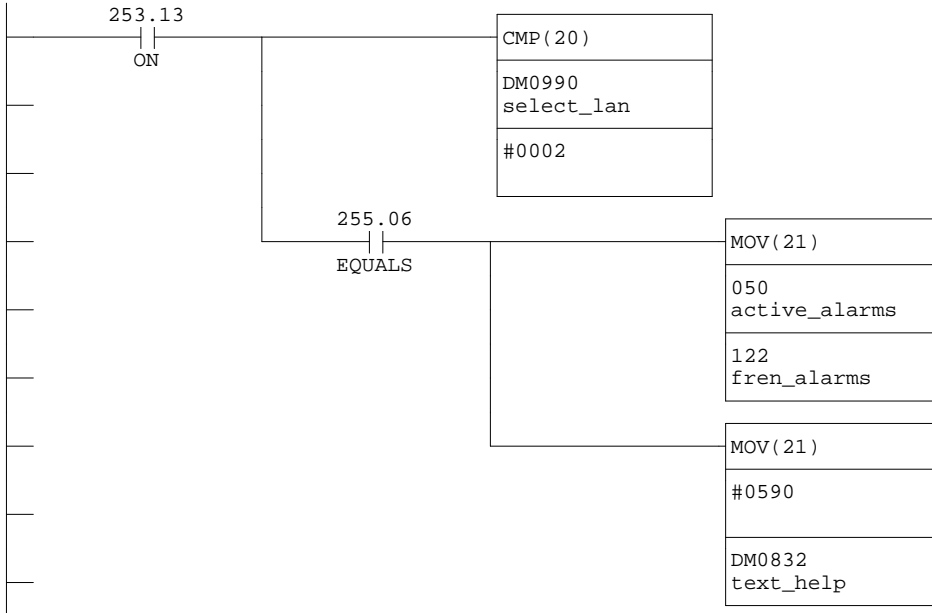
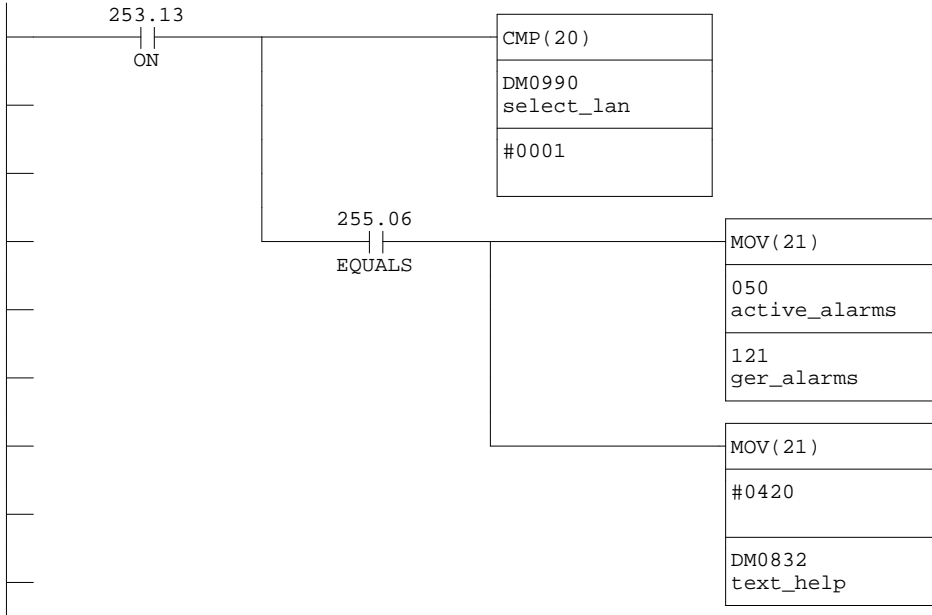



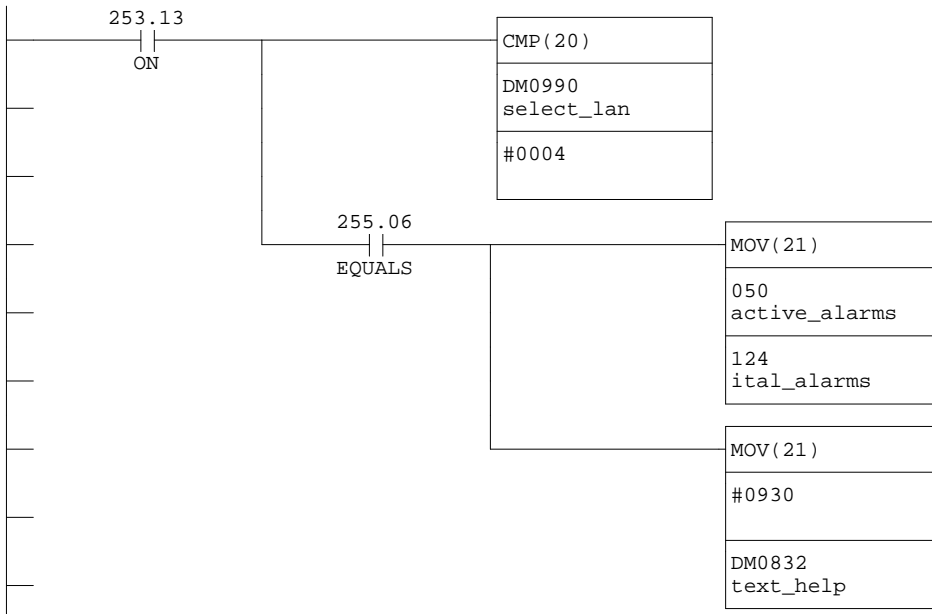
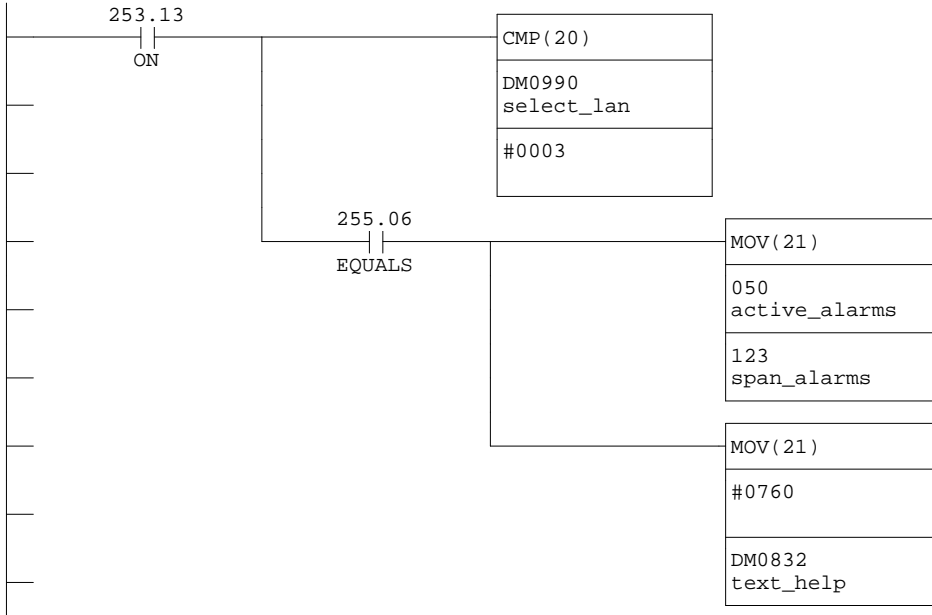

Main 25 - Temp-settings

Network 1 - Temp comm codes

Sets temperature command codes PV, Status, P, I and D values



Network 2 - Wax initiate

Initialises the the wax temperature control settings, eg:- Span limits and alarm value

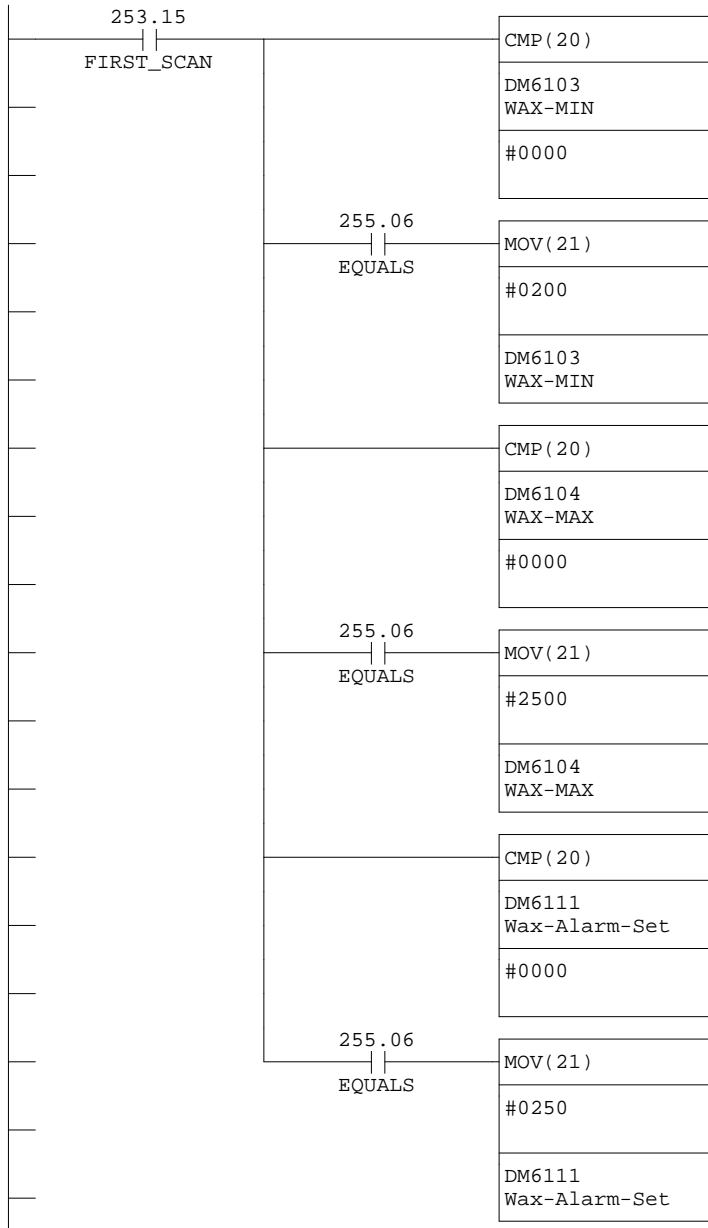

Network 3 - Oven initiate

Initialises the the Oven temperature control settings, eg:- Span limits and alarm value

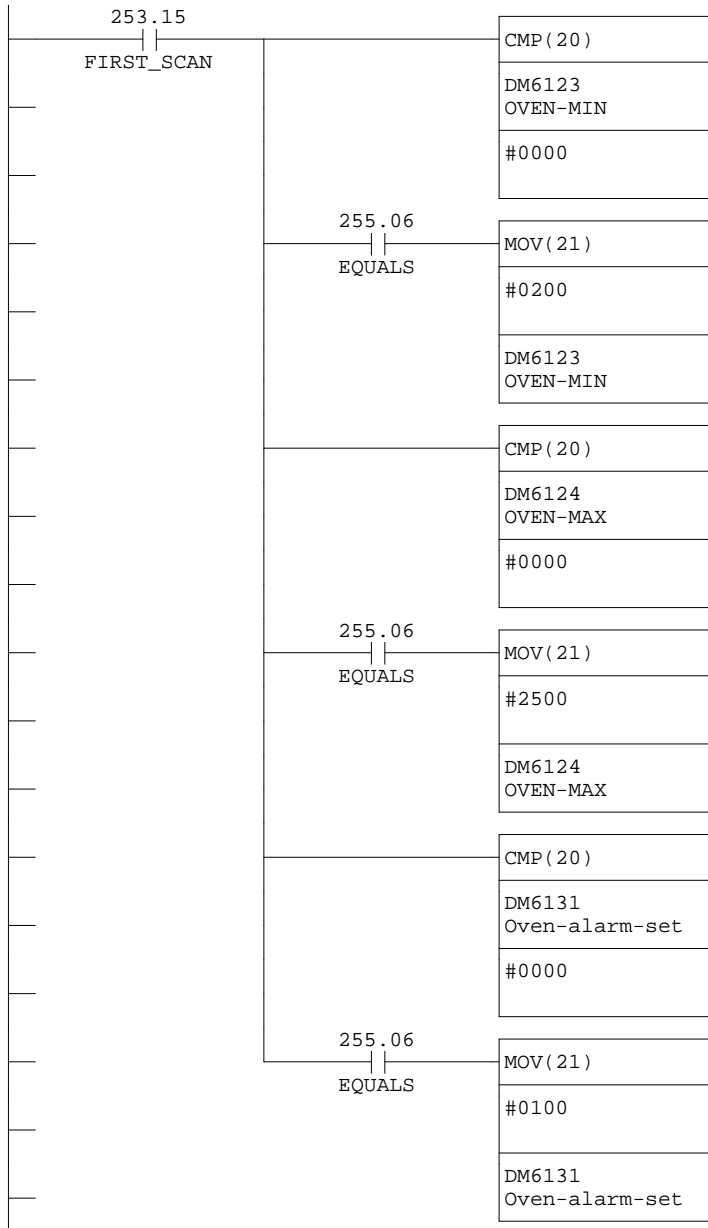

Network 4 - Temp options 1

Selects which Temperature control option(s) are installed and permits acces to the relevant control page on the MMI

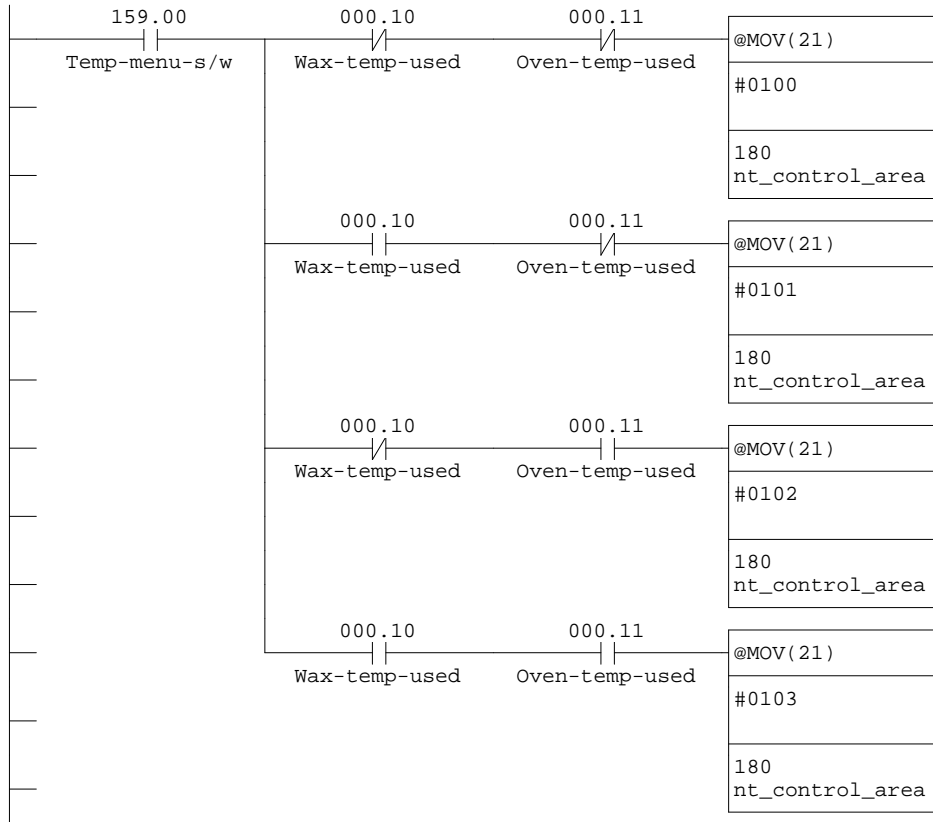

Network 5 - Temp options 2

Selects which Temperature control option(s) are installed and permits access via engineering password page the to the relevant Span limiting settings page on the MMI

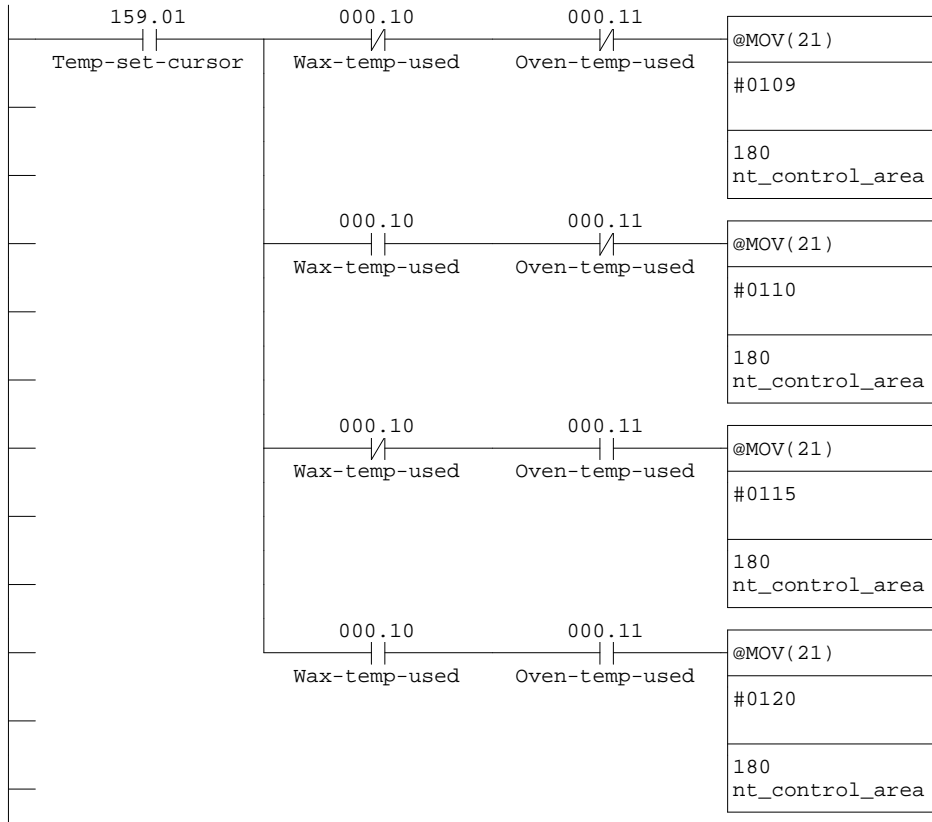

Main 26 - Wax-sw-init

This block controls the Wax Temperature loop setting and display for the on and off states

Network 1 - Heat/sw strobe

Gives a single pulse when the Wax heat switch on the NT is pressed

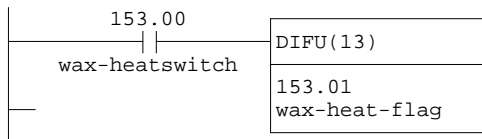

Network 2 - Heat/sw toggle

Uses the heatswitch pulse to toggle bit 154.01 on & off. First scan sets the heat to off position

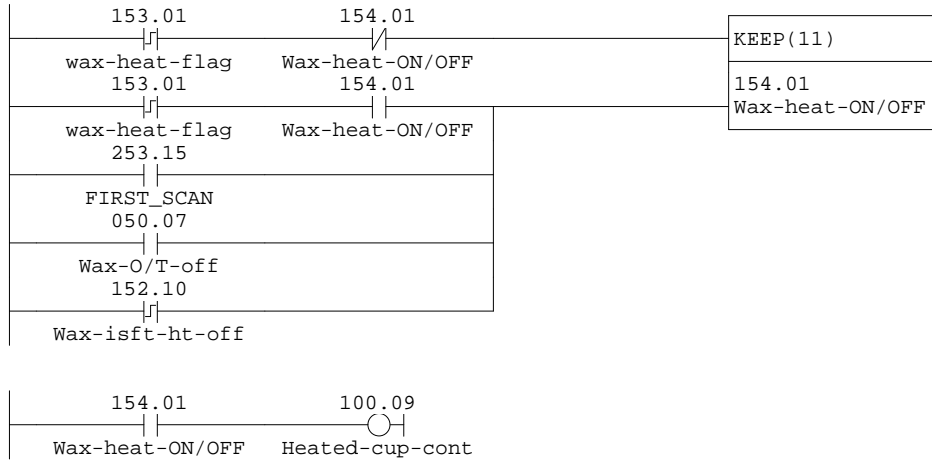

Network 4 - Heat off setting

When the heat switch is toggled off then #CCCC stops the temperature controller from working. This block also sets the PV to display Zero and the staus bits to off. Bit 153.02 is used to initiate the Shift register for the Wax temperature control loop read cycle.

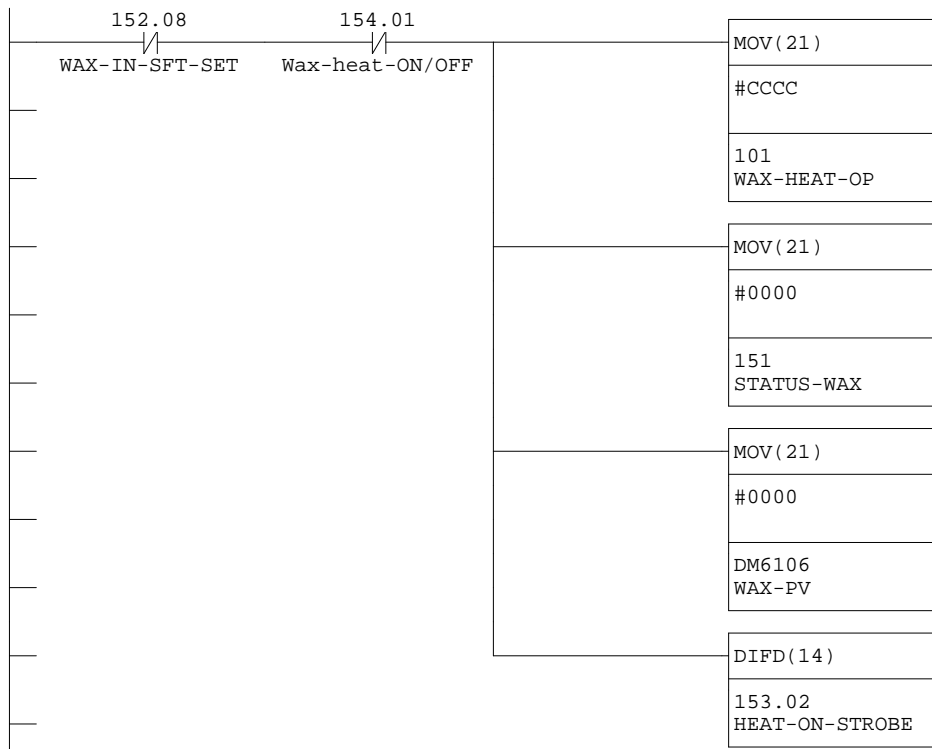

Network 5 - Max-Manual-ops

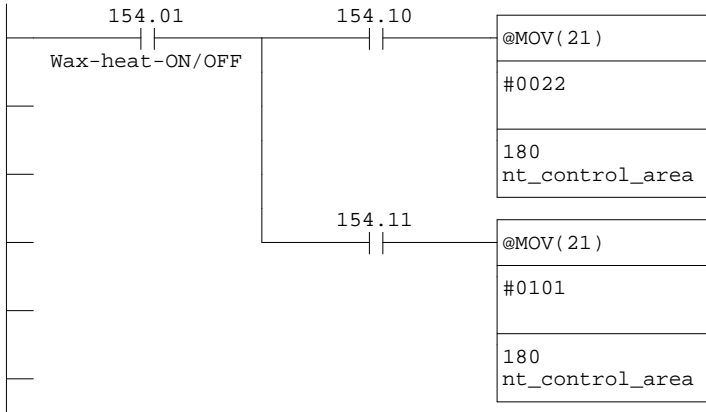

Main 27 - Wax-temp-cont

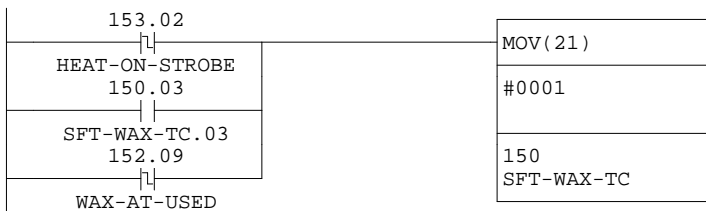
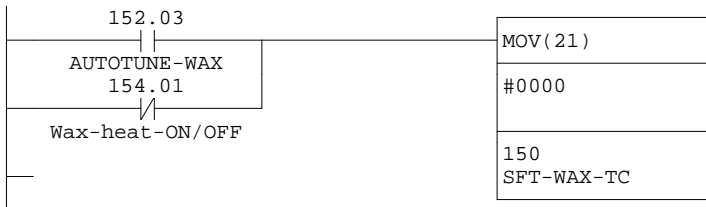
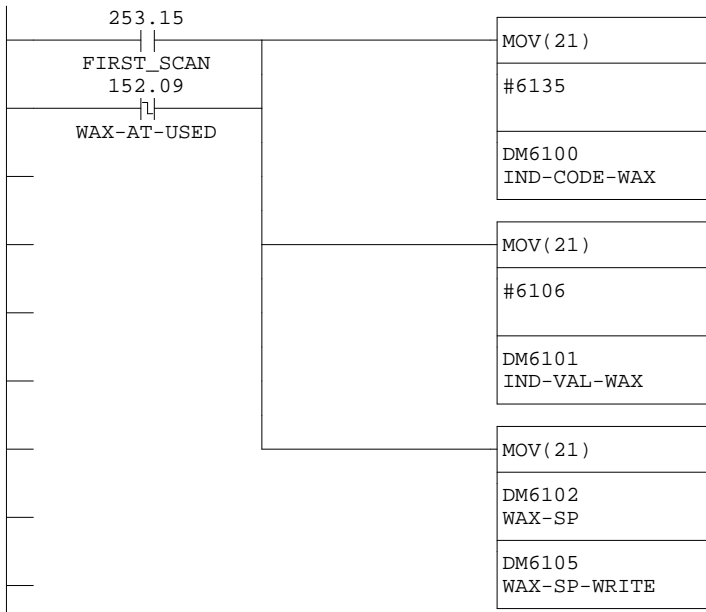



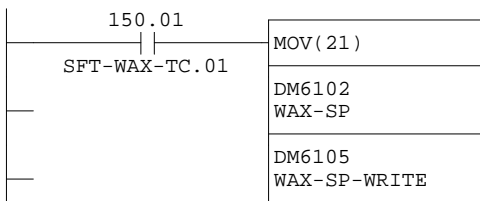
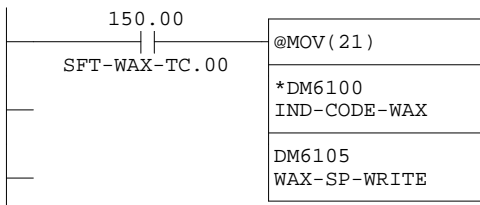
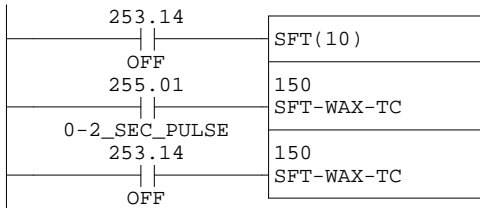
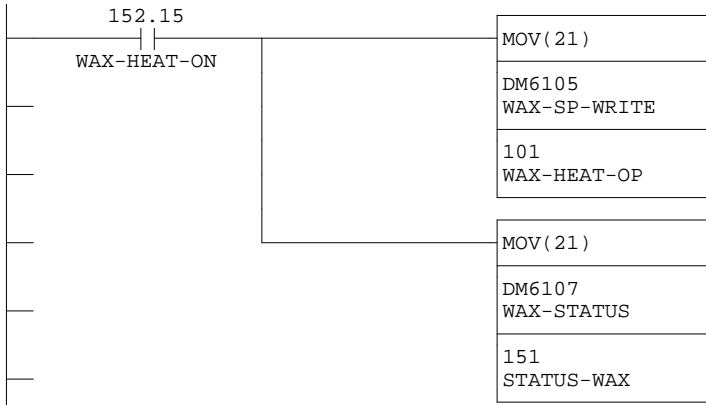
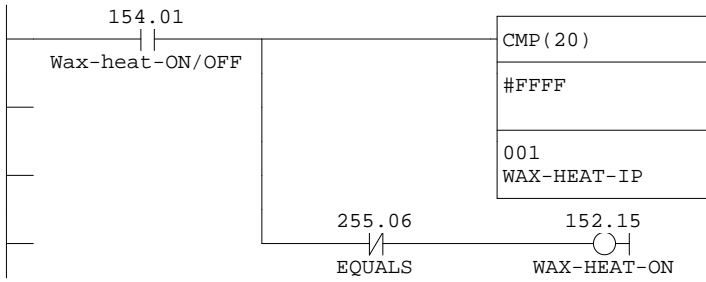

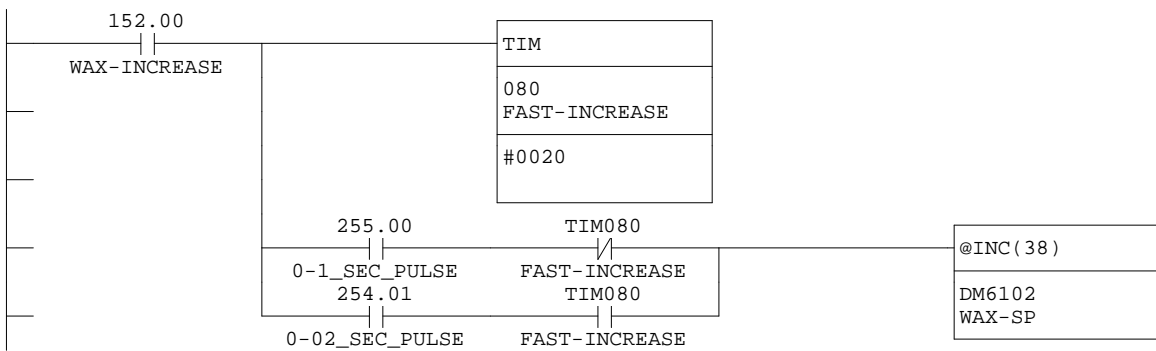
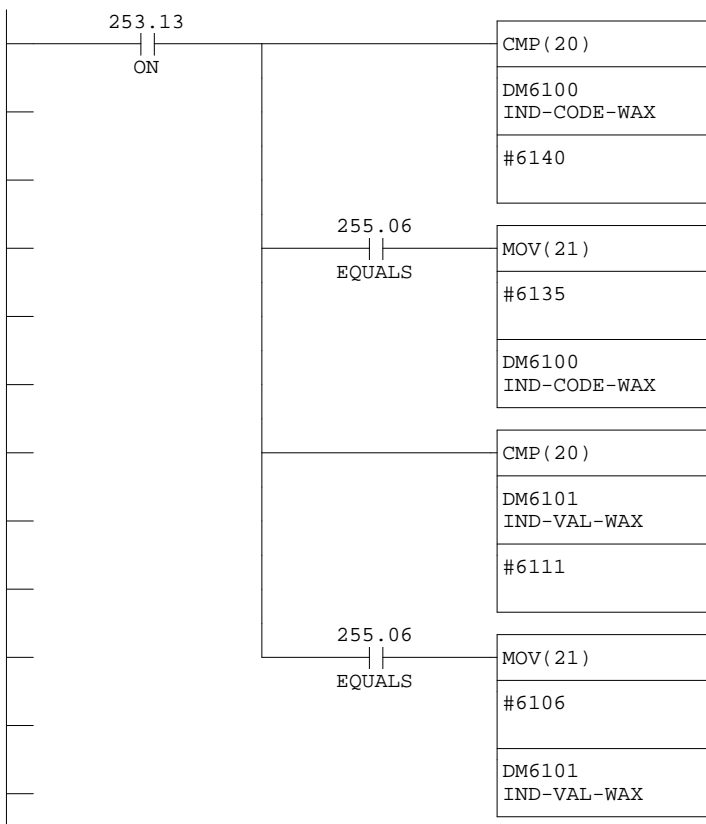
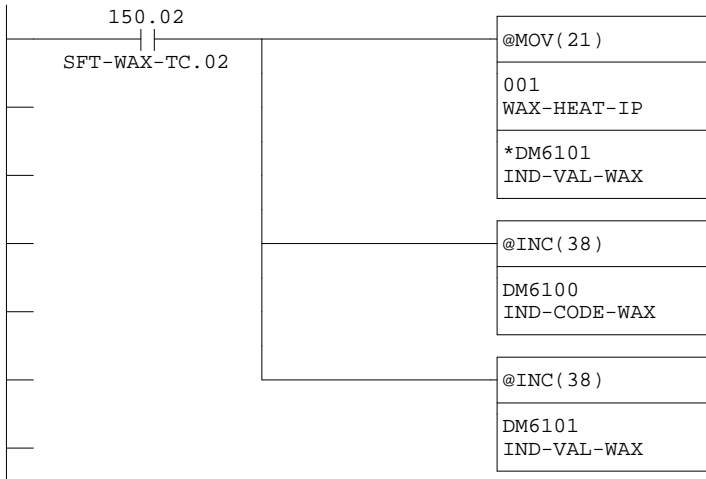

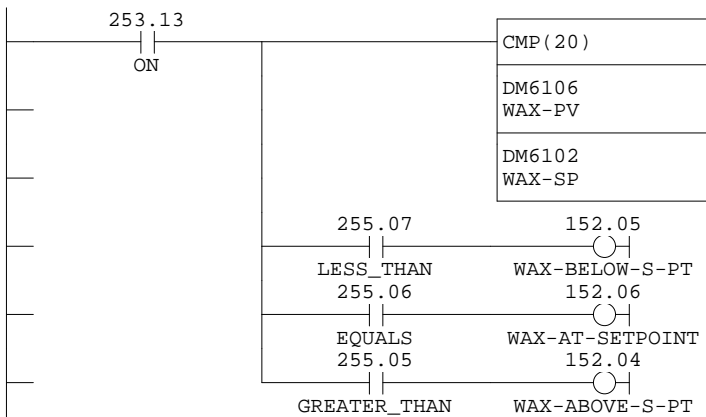
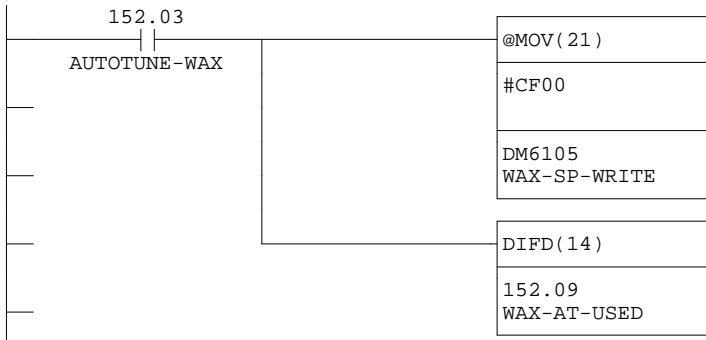
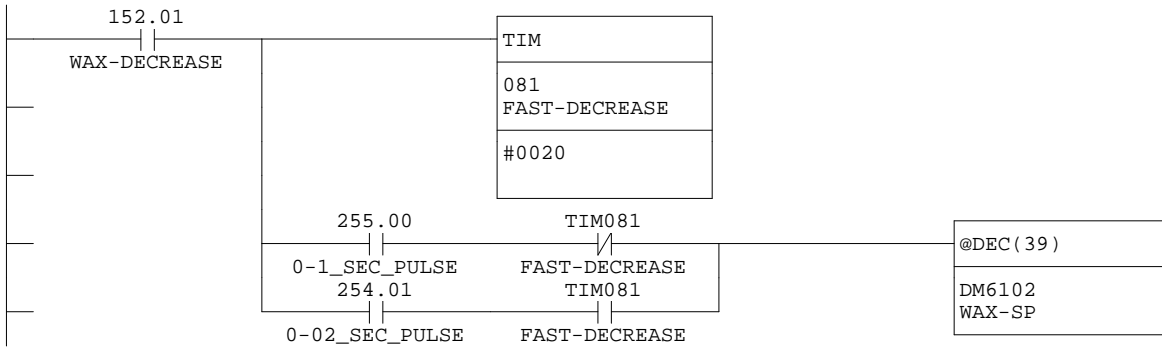

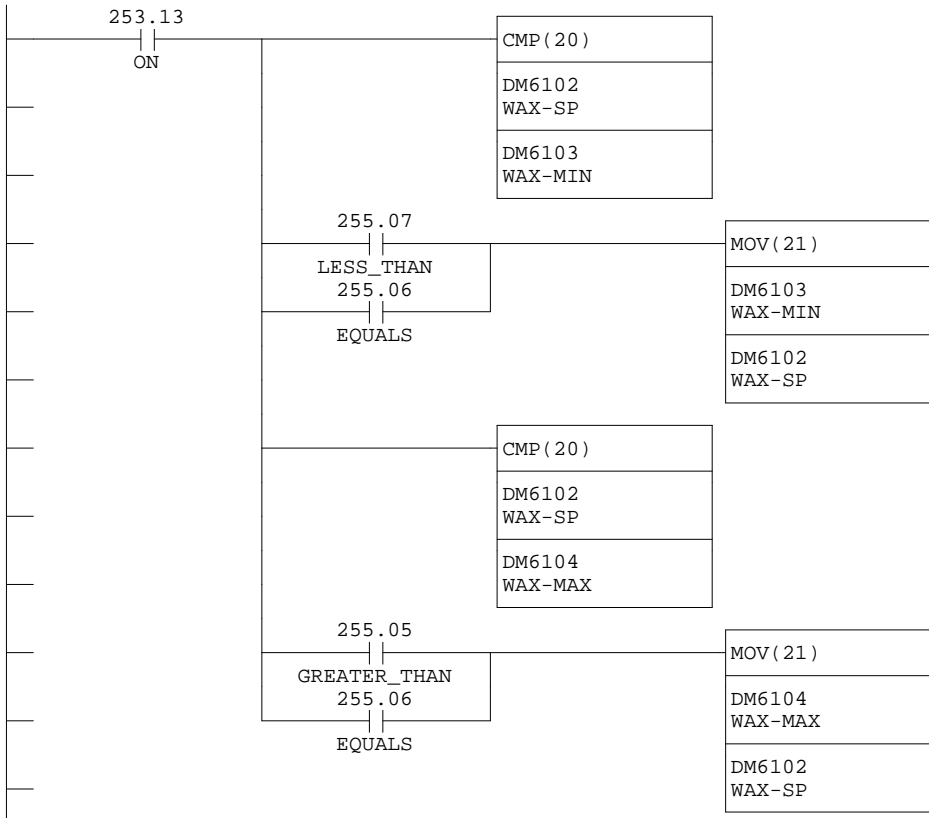

Main 28 - Oven-sw-init

This block controls the Oven Temperature loop setting and display for the on and off states

Network 1 - Heat/sw strobe

Gives a single pulse when the Oven heat switch on the NT is pressed

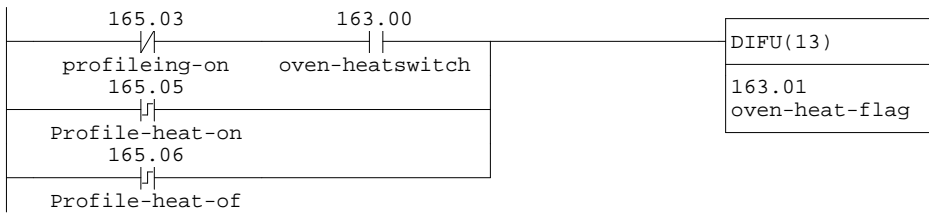

Network 2 - Heat/sw toggle

Uses the heatswitch pulse to toggle bit 154.01 on & off. Furst scan sets the heat to off position

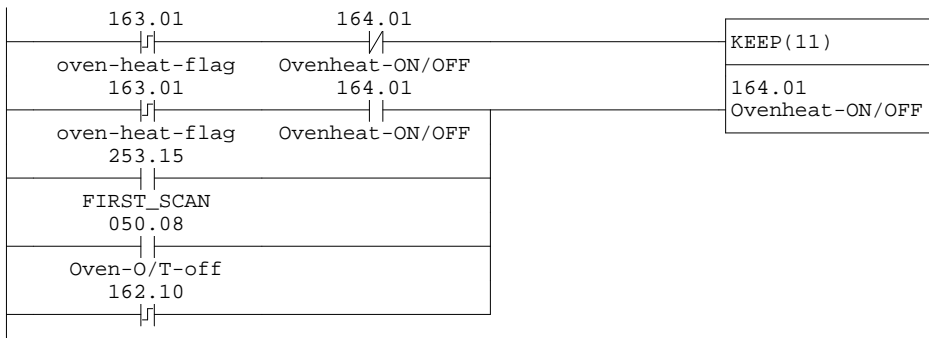

Network 3 - Heat off seting

When the heat switch is toggled off then #CCCC stops the temperature controller from working. This block also sets the PV to display Zero and the staus bits to off. Bit 163.02 is used to initiate the Shift register for the Oven temperature control loop read cycle.

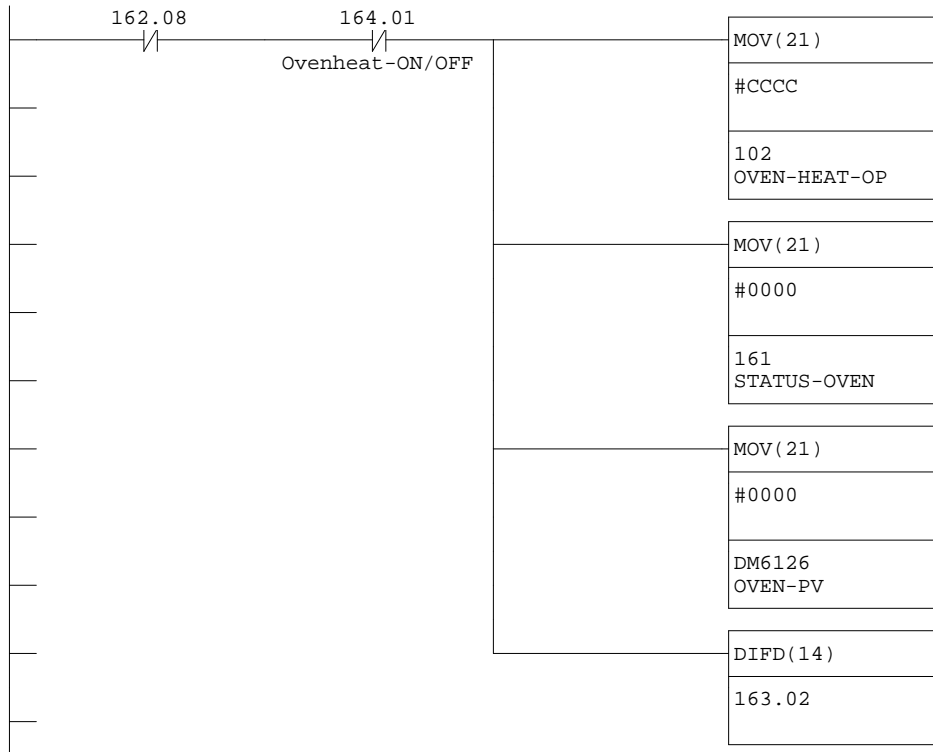

Main 29 - Oven-temp-cont

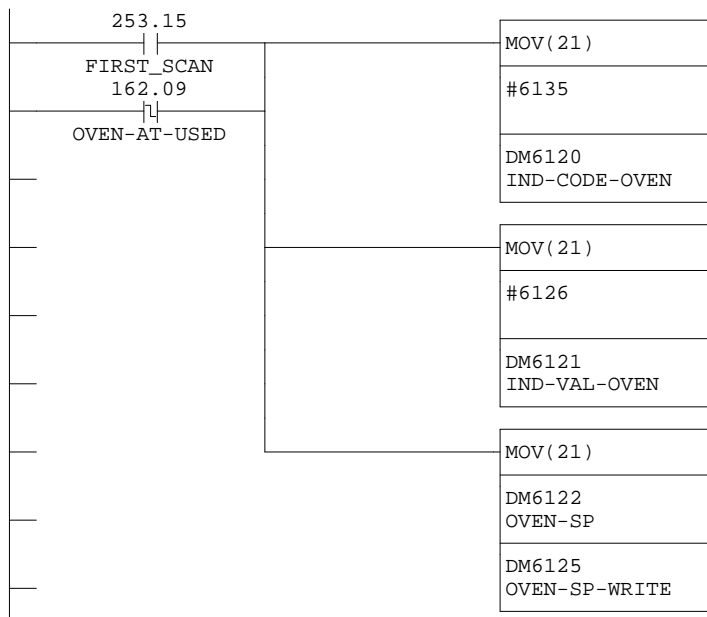

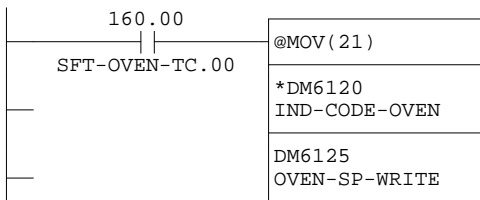
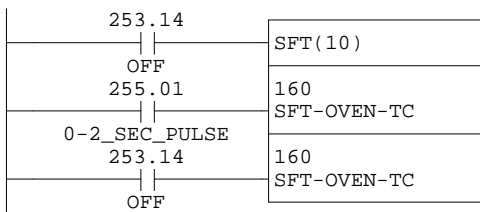
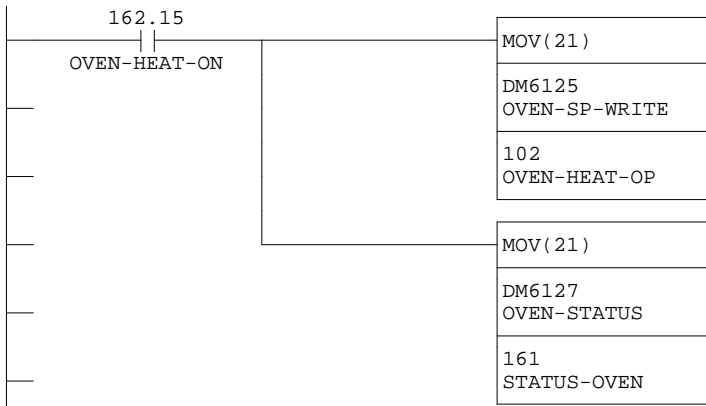
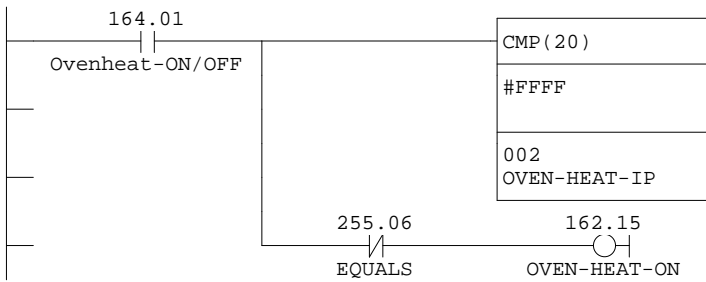
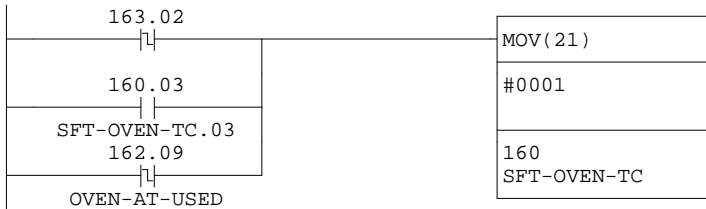
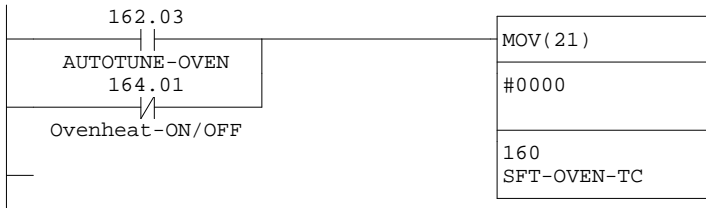

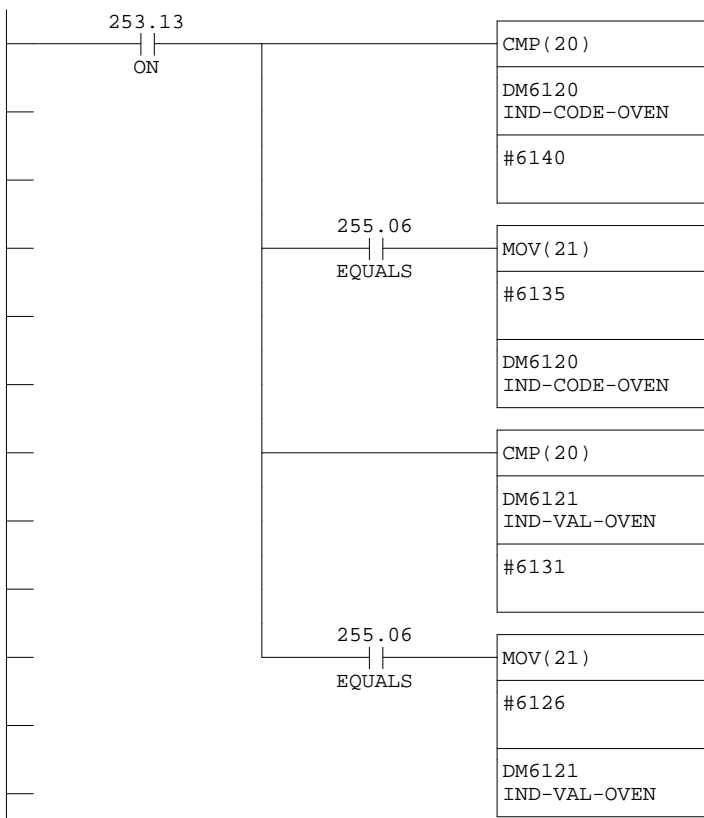
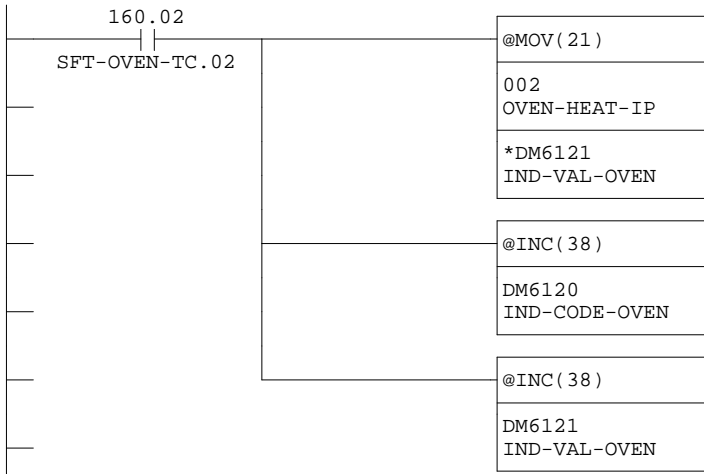
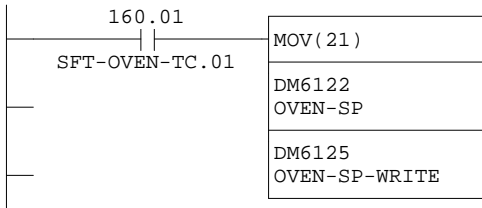

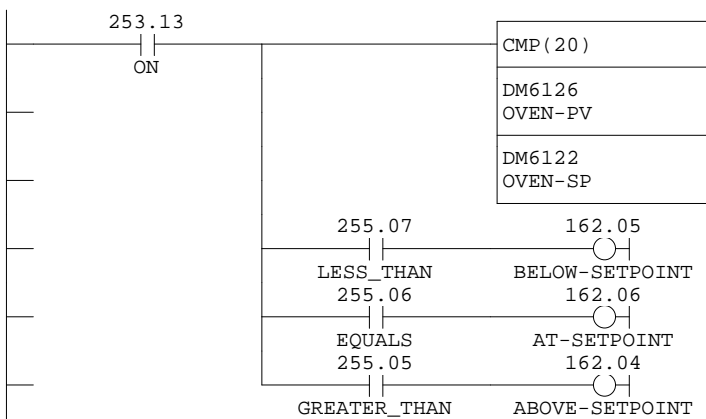
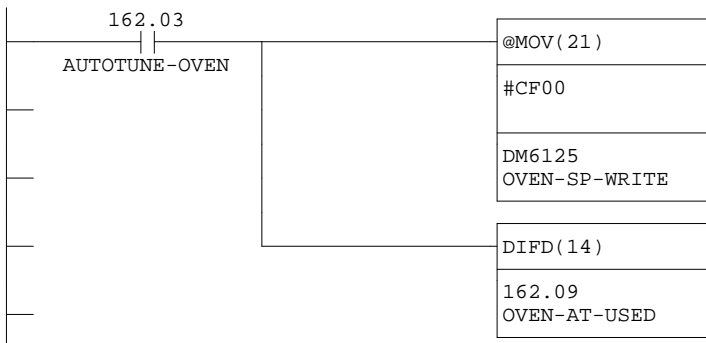
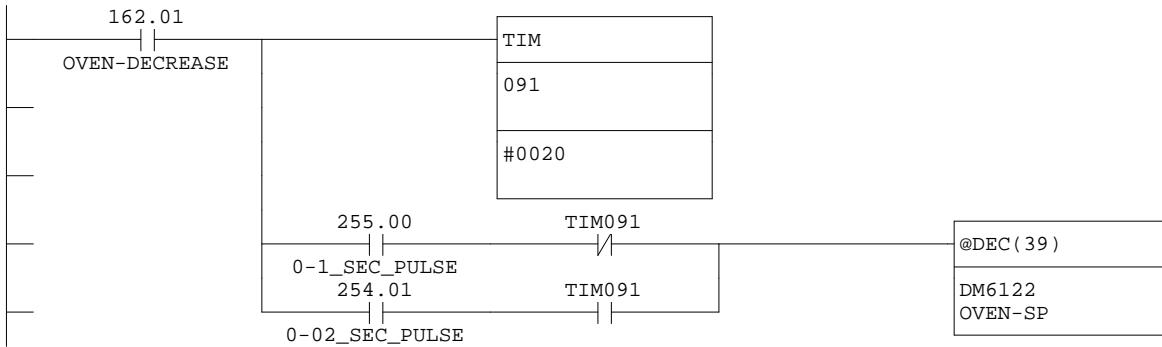
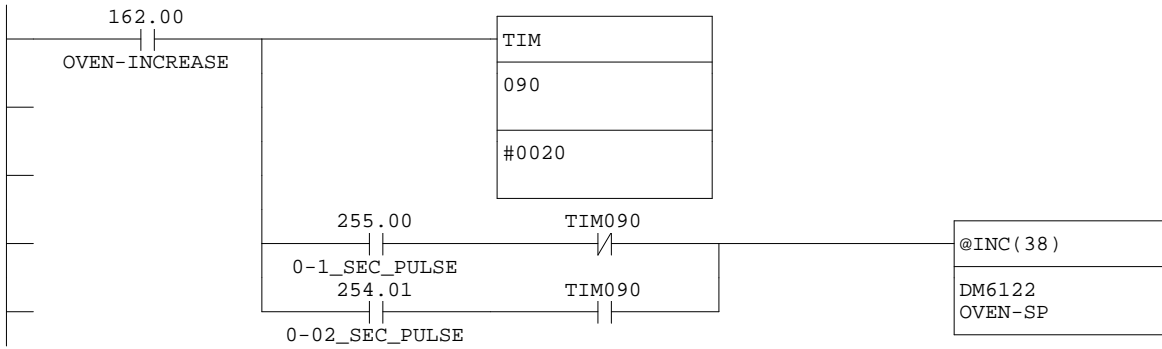



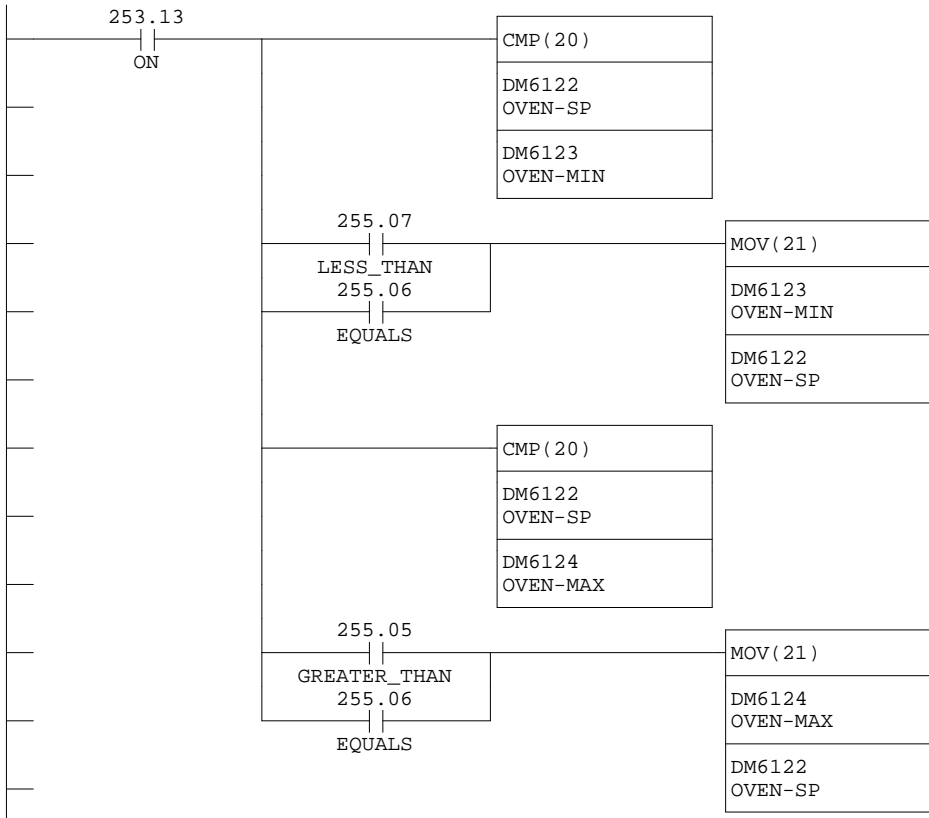

Main 30 - Oven-profiling

Network 1 - New profile

Resets all TEN set points and TEN dwell times to zero for a new program entry

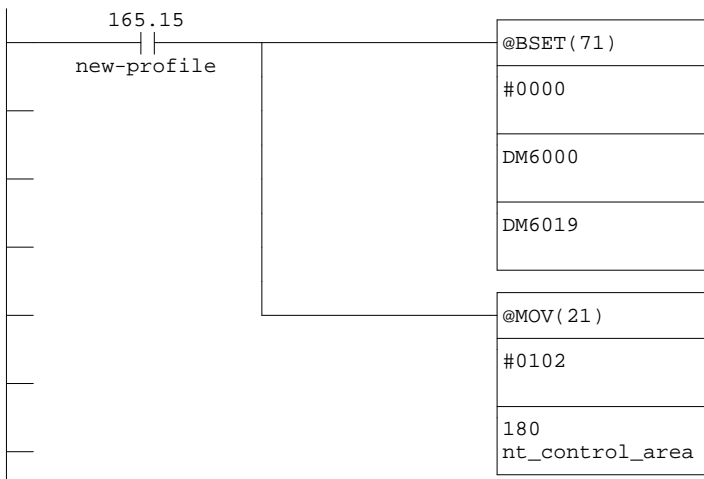

Network 2 - Start Profile

Initialises the indirect DM for the SP and dwell time to the Inatially desired values and sets the profiling flag (165.03) on.

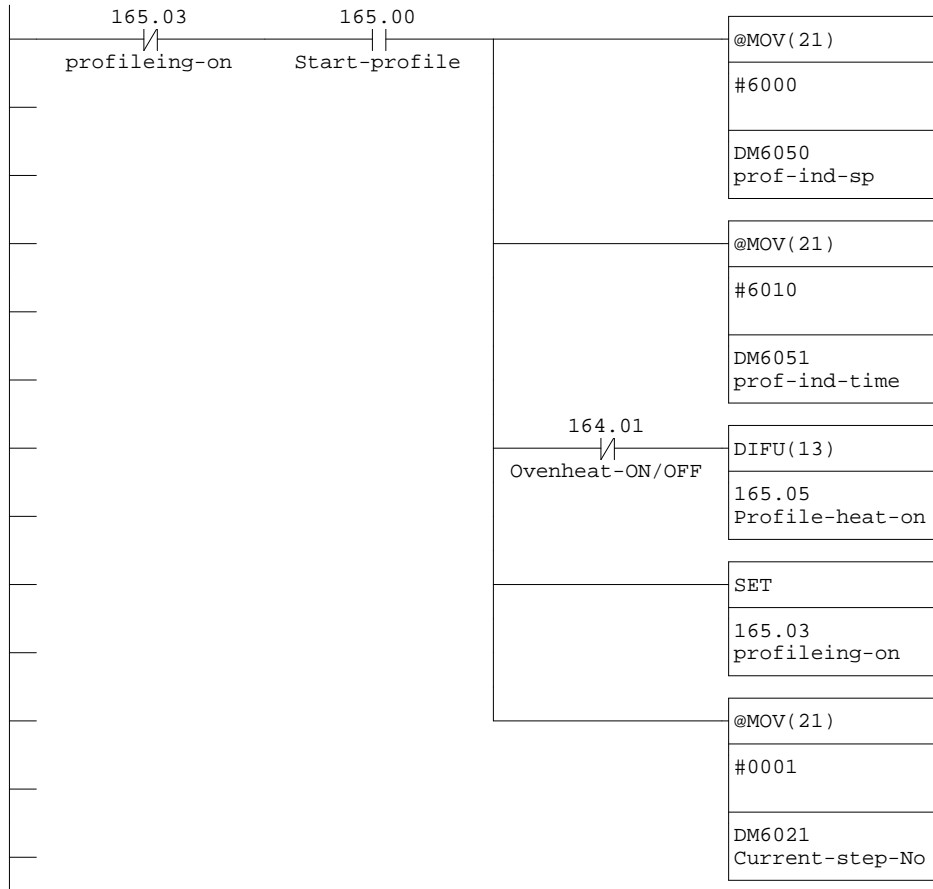

Network 3 - Step Sequence

This block runs each profile step sequence:-  
 Compairs the PV to the desired temperature +/-2 degs, and then starts the dwell time for this segment,  
 when complete resets the timer and steps to the next desired values.

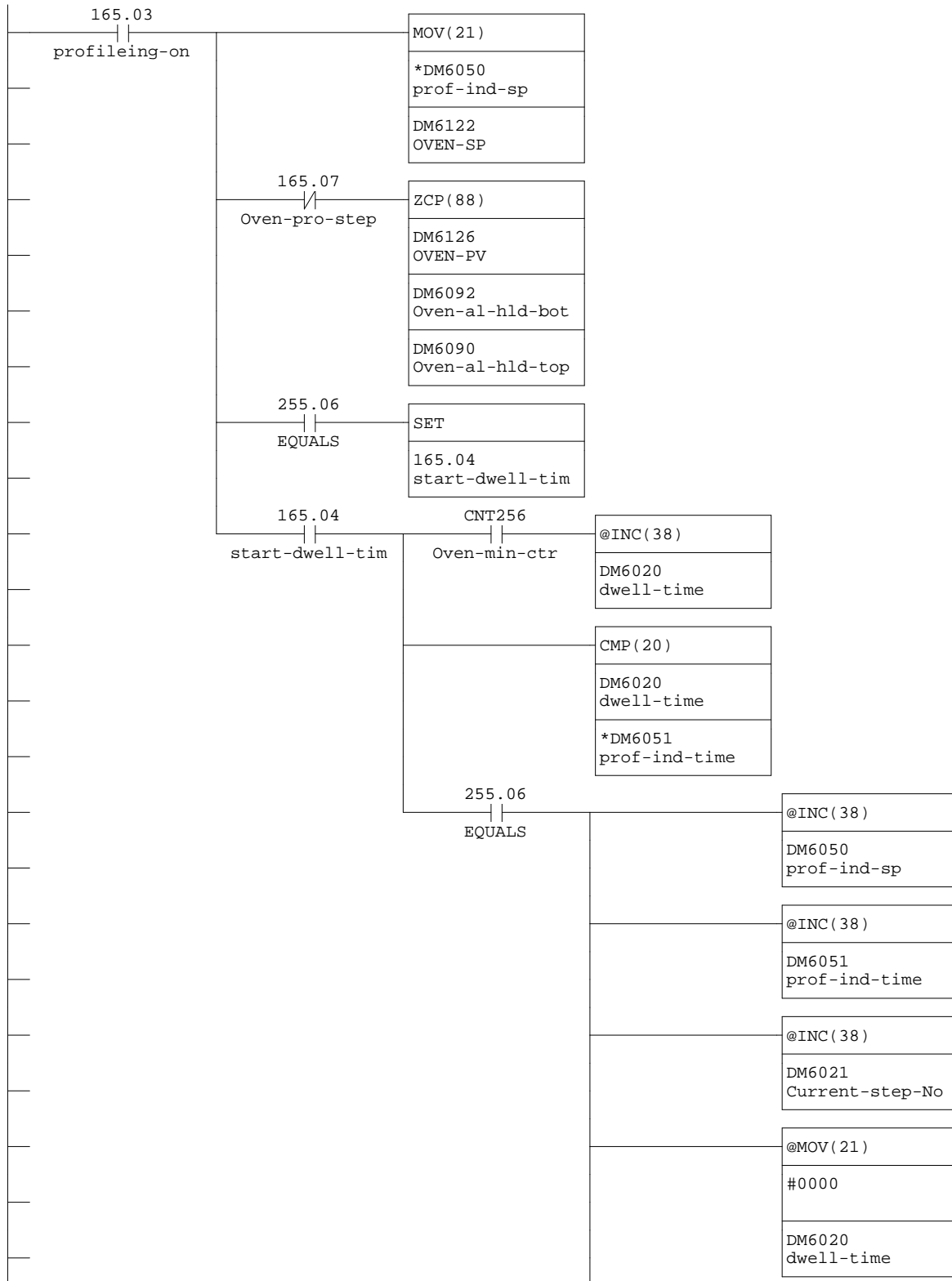



Network 4 - Minute-counter

Counter used to record 60 secs time elapsed.

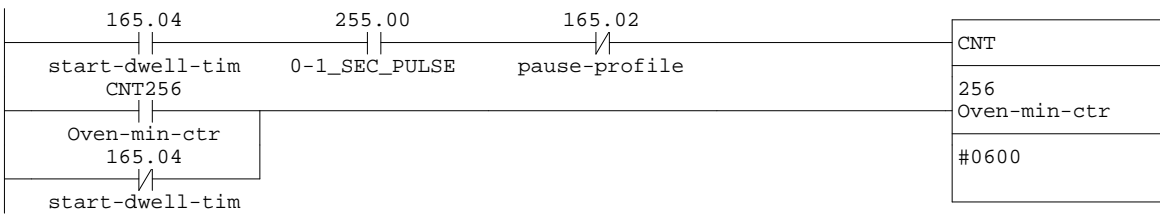

Network 5 - End profile

Compares the SP to #0000 ie:- This = end of profile.

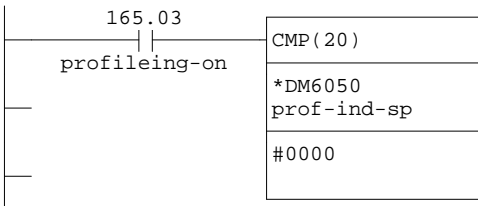

Network 6 - Stop Profile

This effectively stops the profiling sequence and sets the SP to the minimum value set on the SP limiting page.

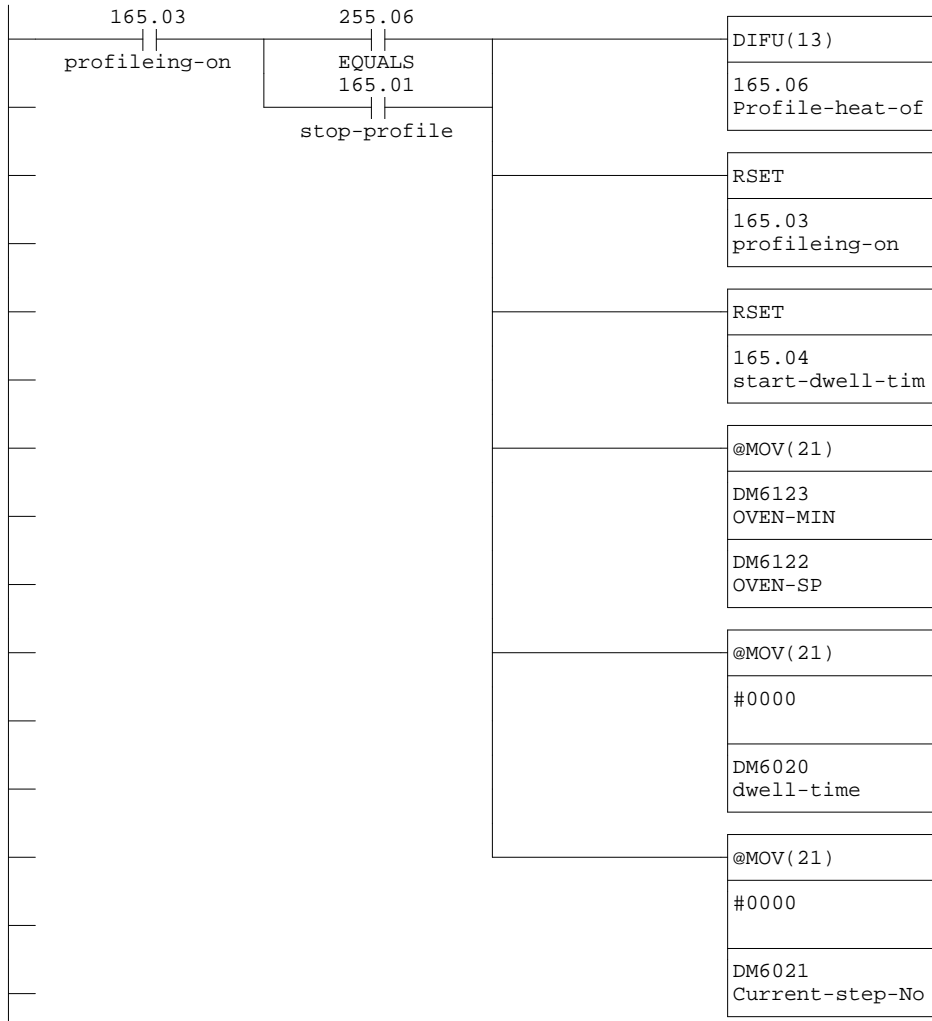

Main 31 - Advanced-Temp

Advanced functions for both temperature control loops.  
Autotune and Input Shift.

Network 1 - Autotune-pg1

Autotune selected for either or both heating loops. This block keeps the Autotune page selected to prohibit other changes being made whilst Auto-tuning.  
NOTE:- HEAT MUST BE SWITCHED ON TO ENABLE AUTOTUNE

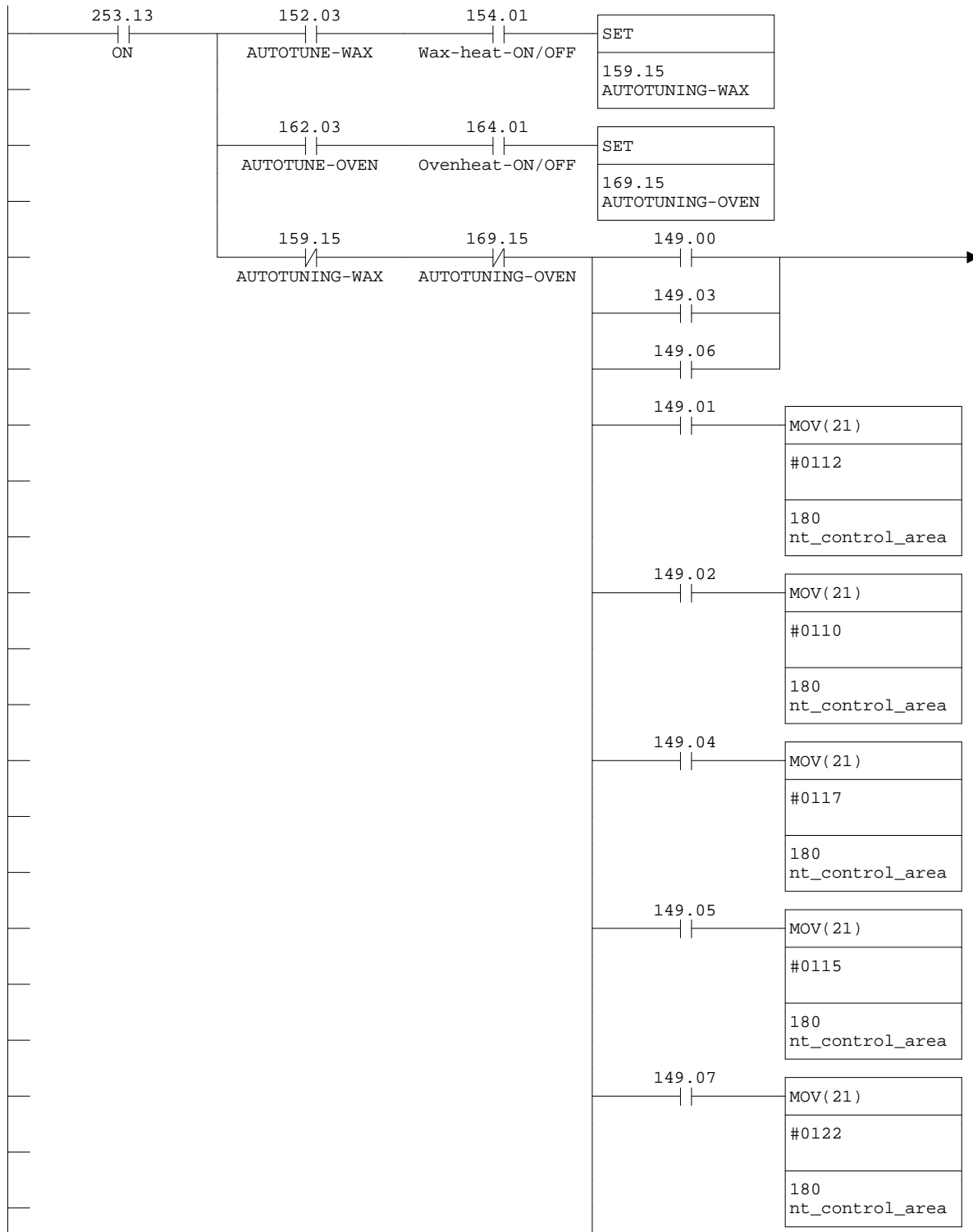

← @MOV(21)
#0010
180 nt_control_area





Network 2 - Autotune-pg2

This block gives a 10 sec delay to enable the Autotune flag to be set confirming that the Autotune is commencing. If this flag is not registered then the screen lock (above) will be released.

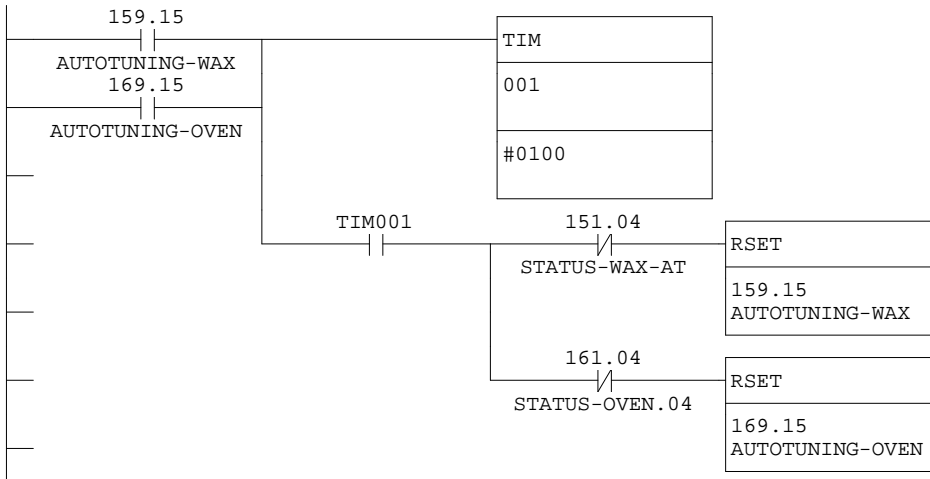

Network 3 - Input shift wax

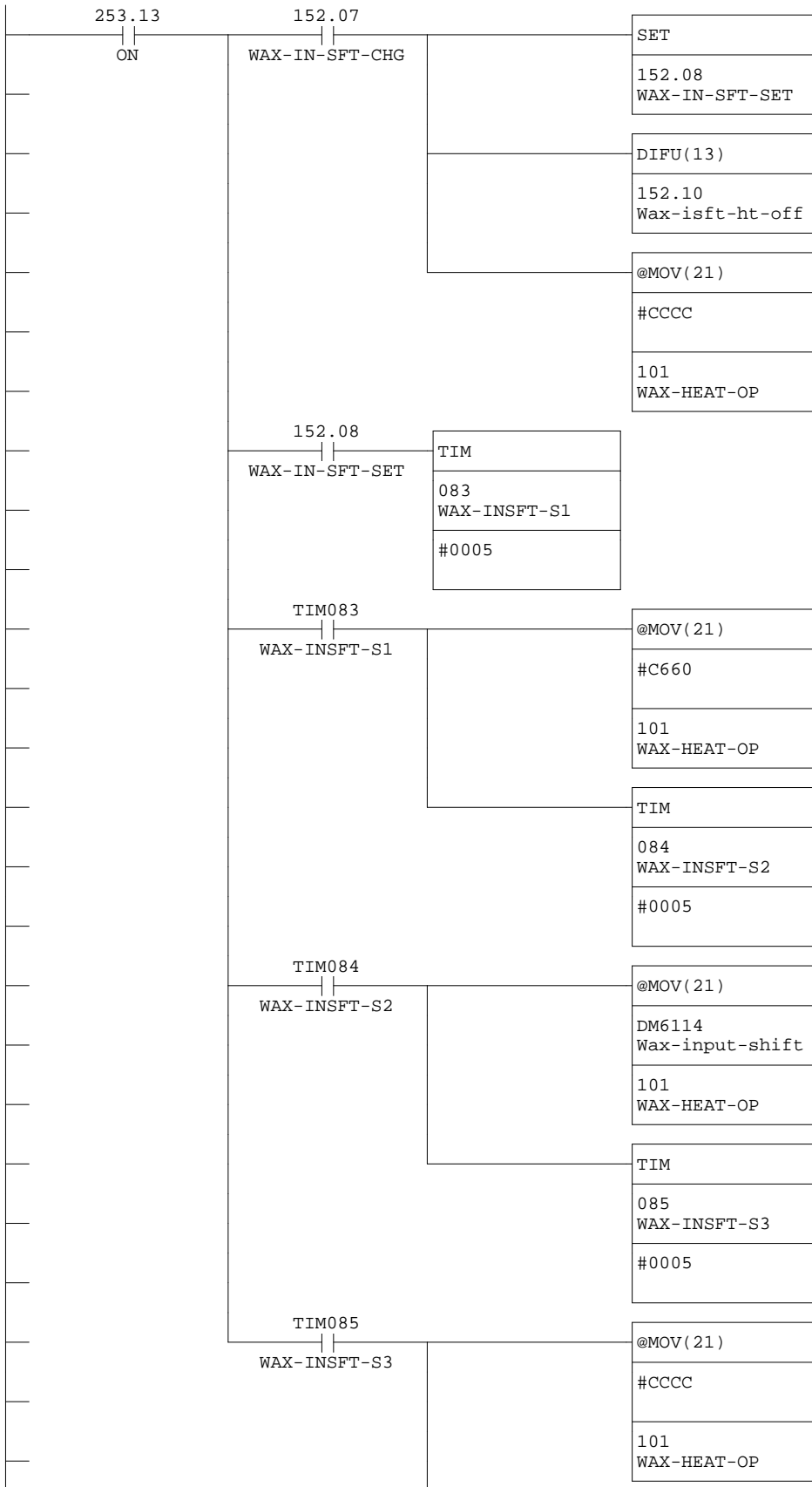

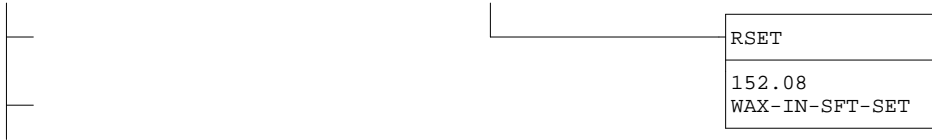

Network 4 - Input shift ovn

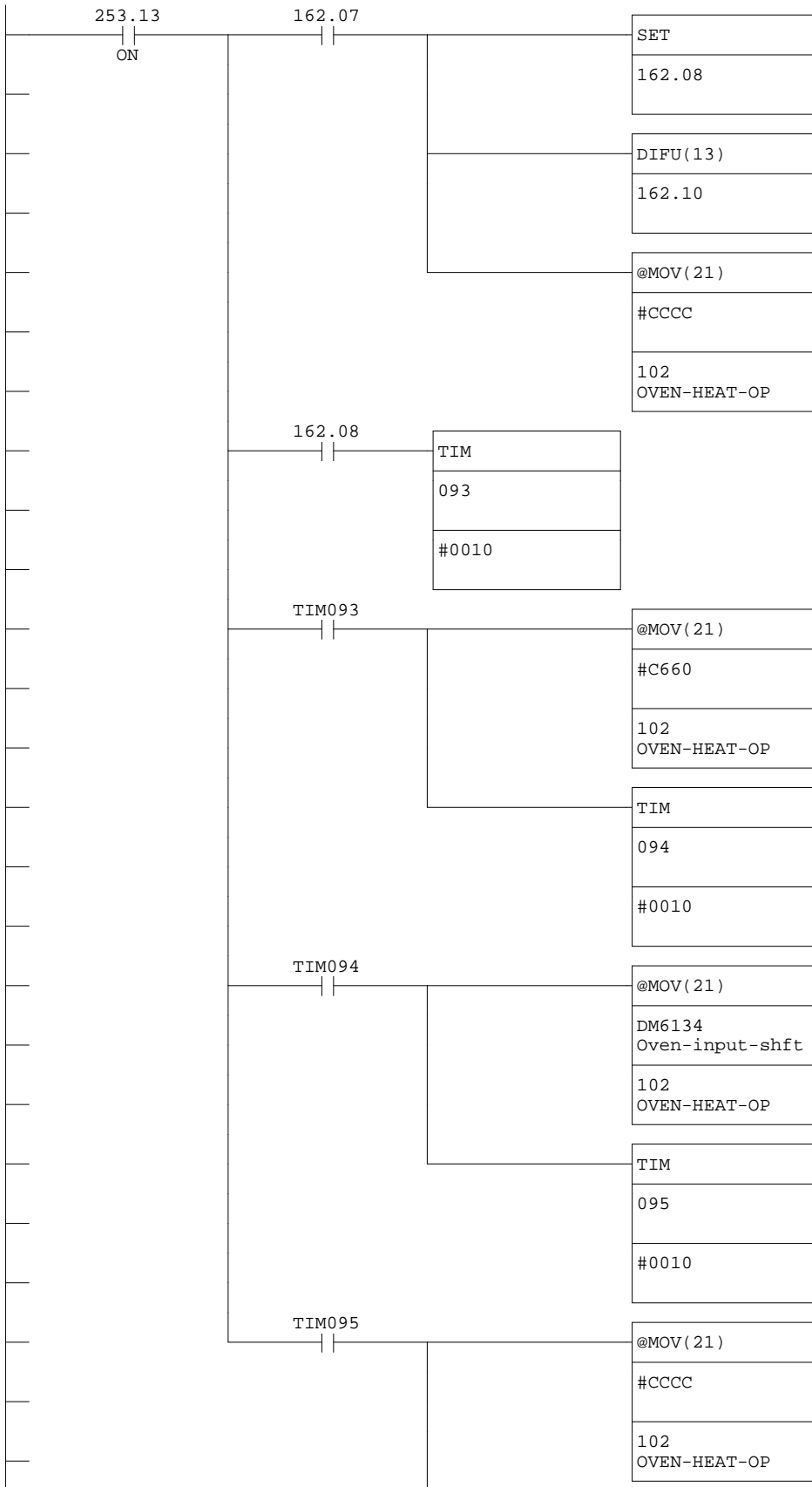

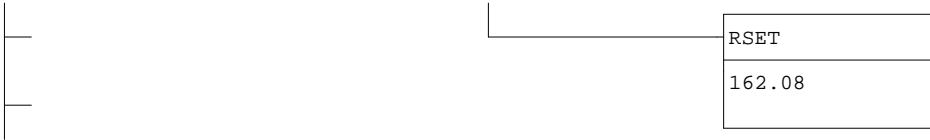

Main 32 - Clock set

Network 1 - NT Clock set 1

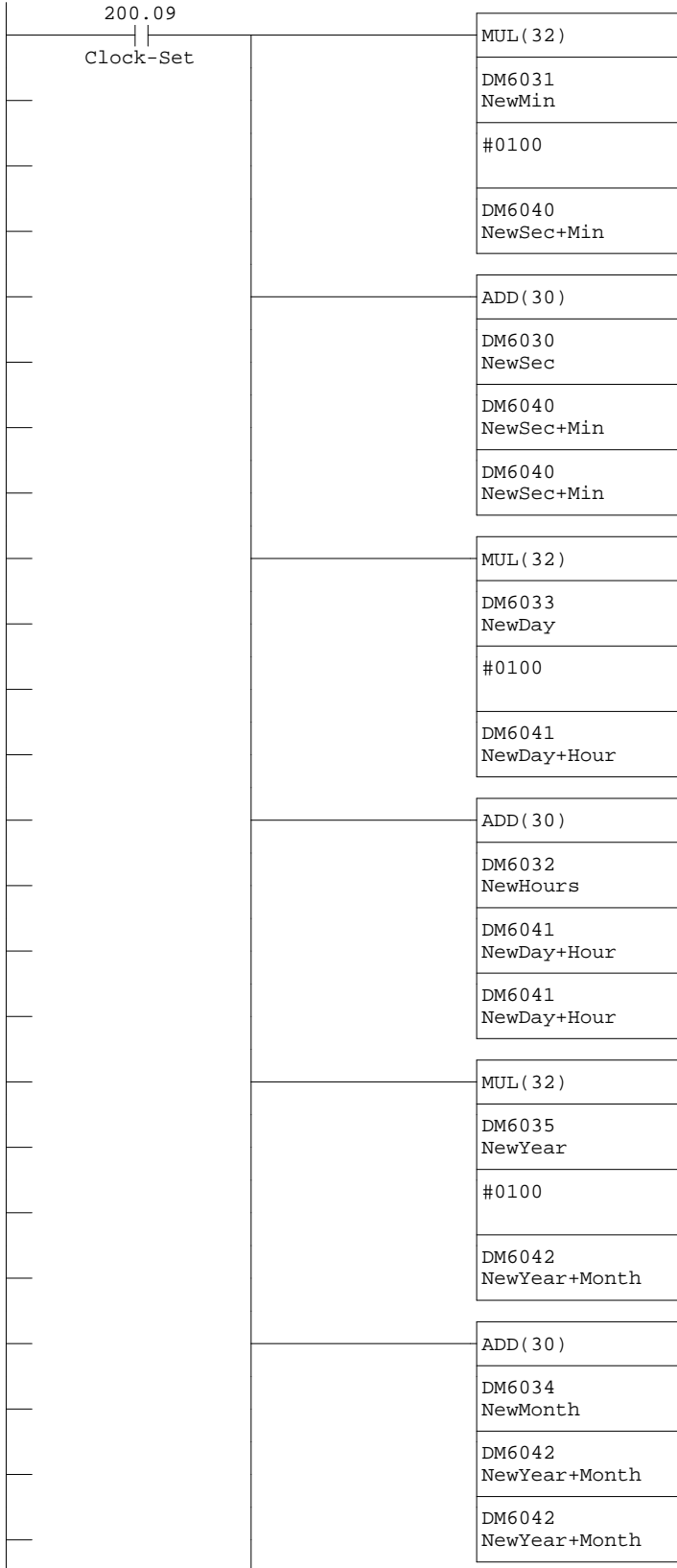

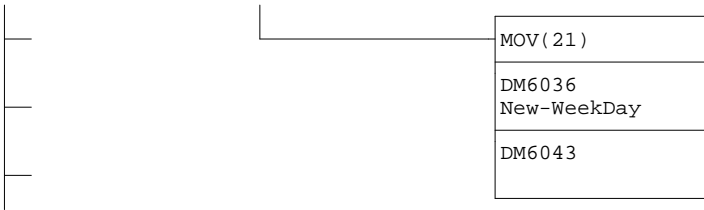

Network 2 - NT Clock set 2

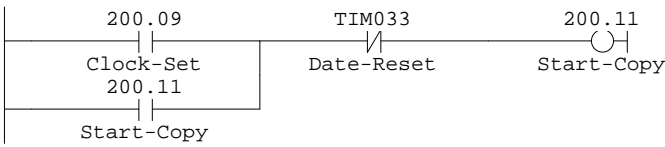

Network 3 - NT Clock set 3

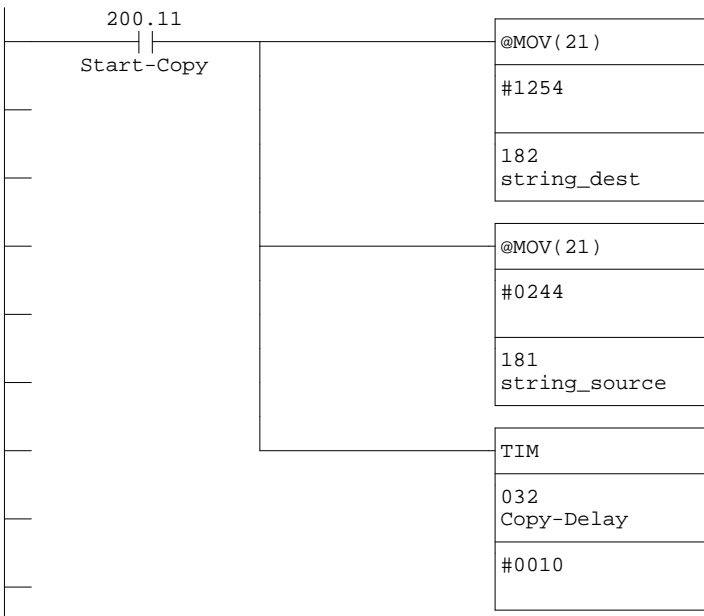

Network 4 - NT Clock set 4

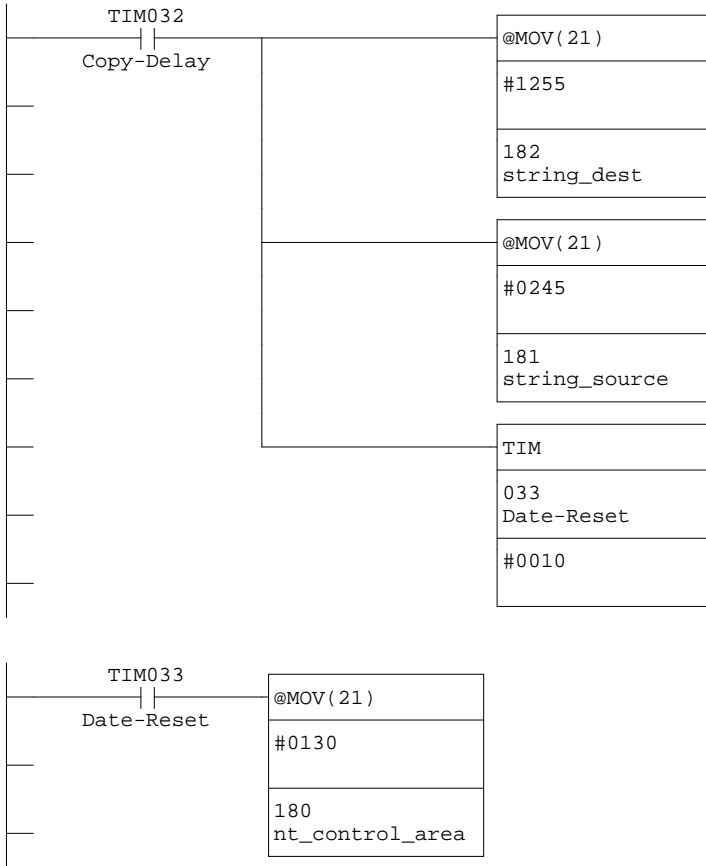

Network 6 - NT Clock Set 5

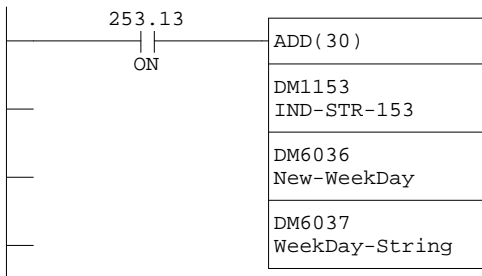

Main 33 - LINK\_CONTROL

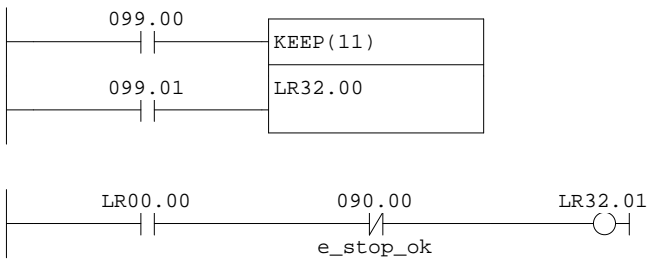



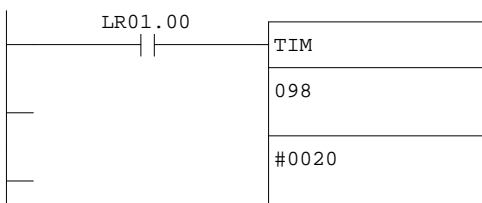
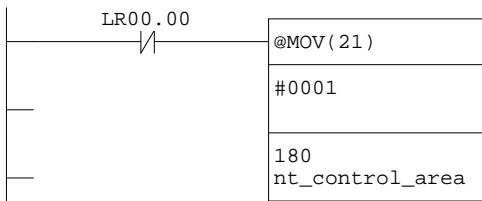
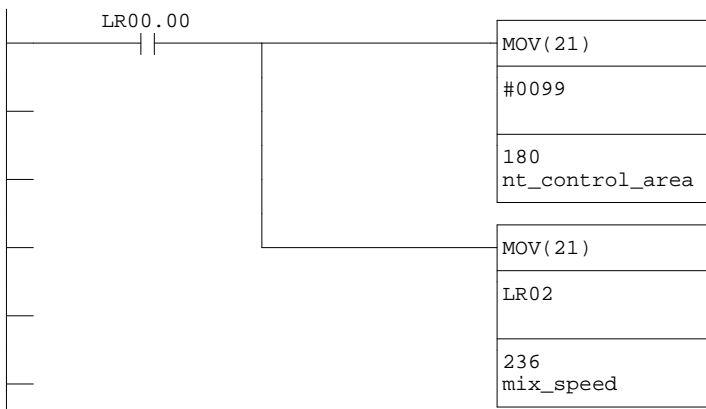
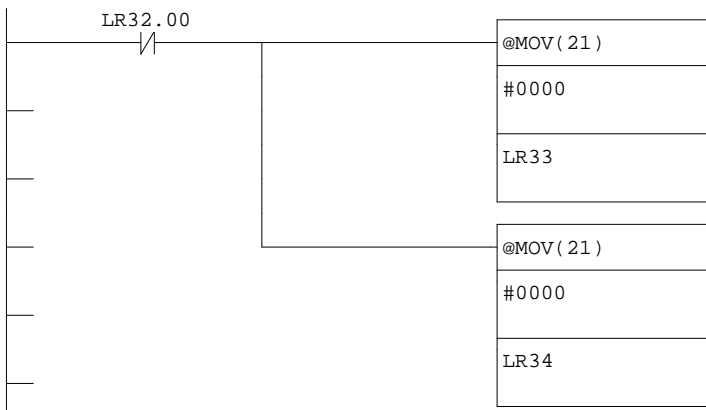
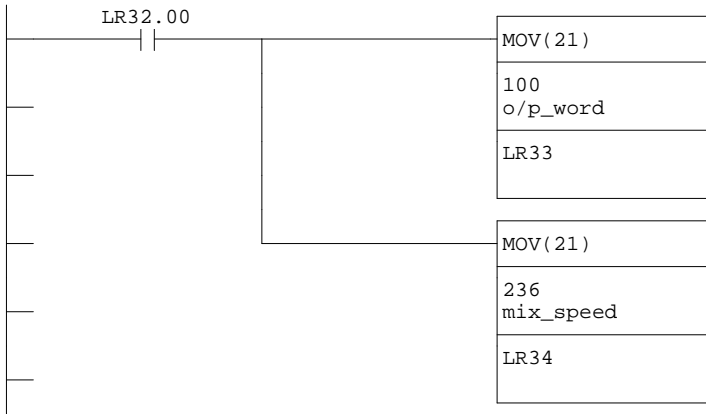

Main 34 - End

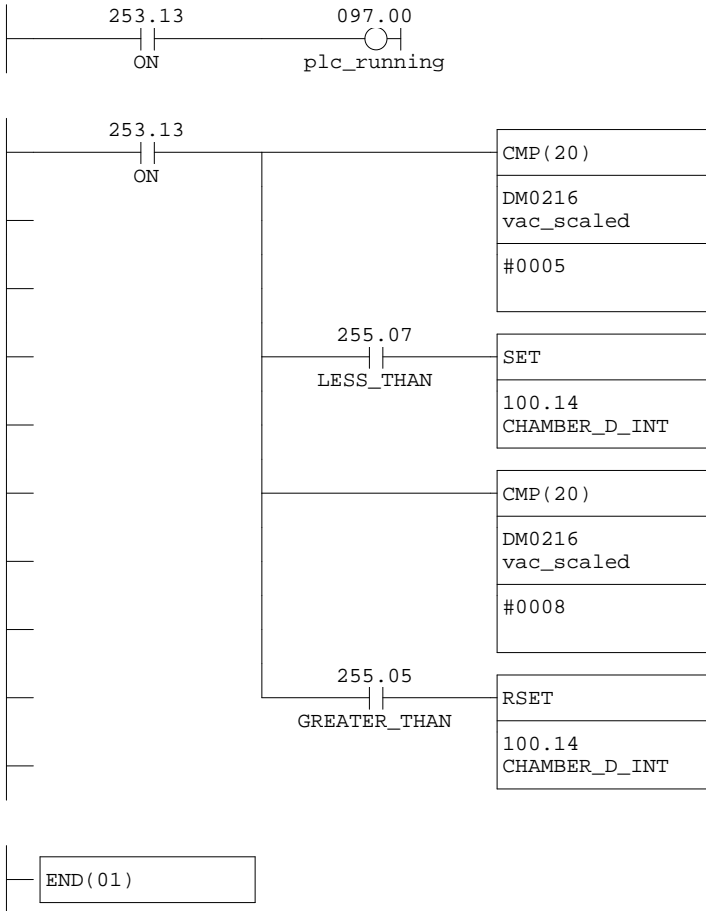

## Startup Processing

Startup Mode : MONITOR  
IOM Hold Bit Status : Reset  
Forced Status Hold Bit : Reset

## Cycle Time Settings

RS232C Port Service Time : Disabled  
Peripheral Port Service Time : Disabled  
Word for Pulse Output : IR0  
Cycle Monitor Time : Fixed at 120 ms  
Scan Time : Variable

## Error Settings

Detect long cycles  
Detect low battery voltage

## Peripheral Port Settings

Use Default 9600,7,E,2  
Communications Mode : Host link  
Start code : Disabled  
End code : Number of bytes received : 256  
Transmission delay (\*10ms) : 0  
Node number : 0

## RS232C Port Settings

Use Default 9600,7,E,2  
Communications Mode : 1-to-1 NT link  
Words linked for 1:1 link : LR 00 to LR 63  
Start code : Disabled  
End code : Number of bytes received : 256  
Transmission delay (\*10ms) : 0  
Node number : 0